

Zero Waste

Design Guidelines

Design Strategies and Case Studies for a Zero Waste City

Contents

04	About the Guidelines	175	Chapter 03: Collection & Urban Design
07	Introductions	176	Collection & Urban Design Context
11	How to Use the Guidelines	190	Collection & Urban Design Best Practice Strategies
12	Executive Summary	201	Collection & Urban Design Case Studies
16	What is Zero Waste?	220	References
18	Chapter 01: Context	223	Chapter 04: Policy, Research & Implementation Recommendations
19	Waste is a Design Flaw	225	Policy Suggestions
26	How Did We Get Here?	232	Research Recommendations
31	How Can Design Help Us Change the System?	234	Implementation Recommendations
38	References	239	References
40	Chapter 02: Building Design	240	Appendix
41	Residential Building Context	241	Best Practice Strategies for Building Design
63	Commercial Building Context	245	Best Practice Strategies for Construction & Demolition Waste
80	Institutional Building Context	247	Best Practice Strategies for Collection & Urban Design
84	Residential, Commercial & Institutional Best Practice Strategies	248	Building Rules & Standards
122	Construction & Demolition Waste Context	249	Building Standards & Certifications
130	Construction & Demolition Waste Best Practice Strategies	250	LEED v4 Waste Management Credits
137	Building Design Case Studies	256	Definitions
173	References	257	Acronyms
		258	Waste Calculator Assumptions & References
		261	Photo Credits
		262	Acknowledgements

About the Guidelines

These guidelines are dedicated to maintenance workers: the people who manage the materials we casually use and discard each day. Without them, we would be buried.

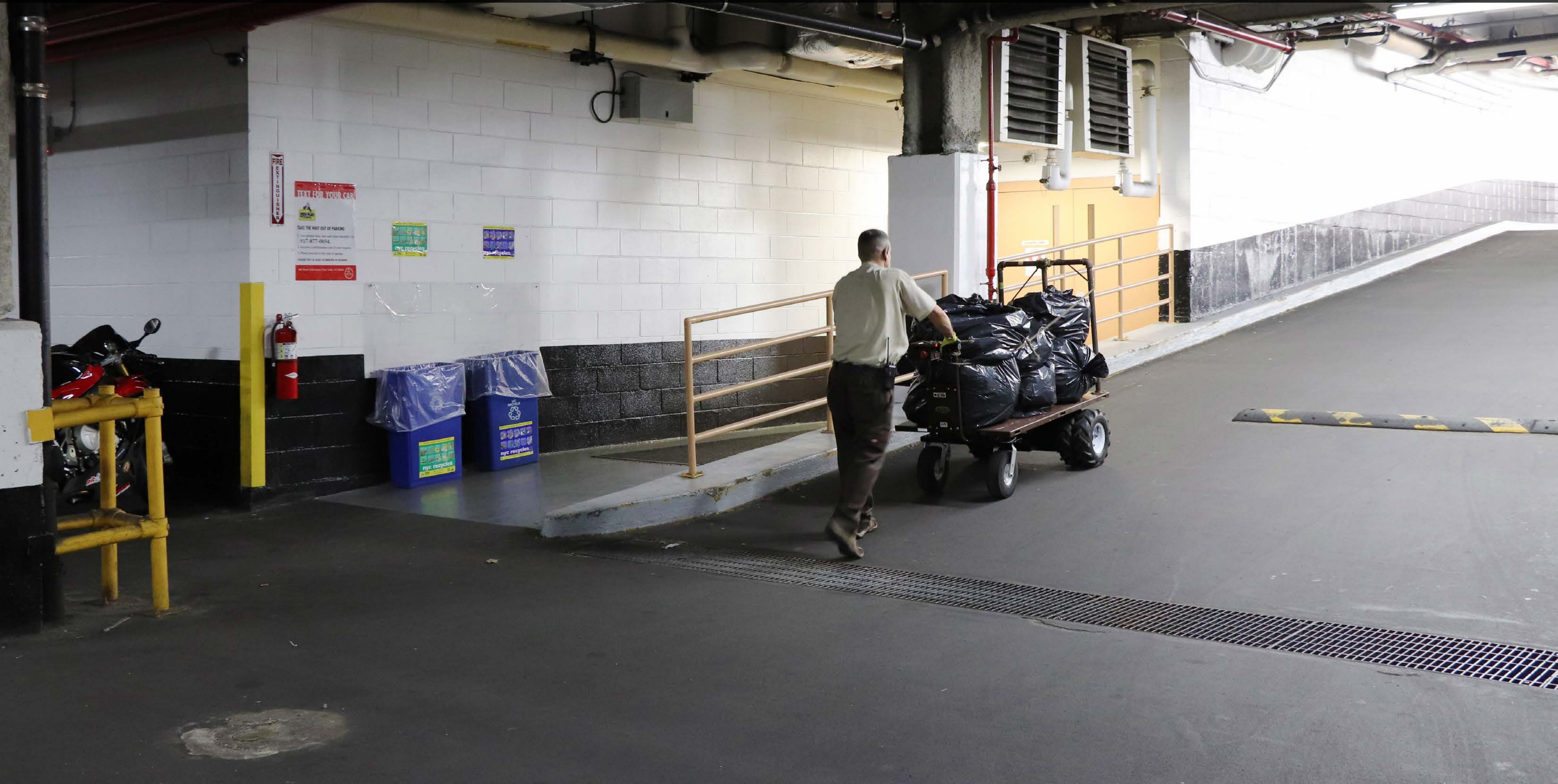

Thanks

These recommendations would not have been possible without the involvement of the advisory committee—an expanding group of workshop attendees—and the maintenance staffs who patiently showed the team their buildings and explained how they manage the waste streams produced each day. The advisory committee included city agency representatives, developers, architects, engineers, building managers, waste management professionals, sustainability consultants and university researchers (see [Acknowledgments](#)).

The involvement of city agencies—especially the New York City Department of Sanitation, along with the departments of City Planning and Transportation and the Mayor’s Office of Sustainability—was essential. Representatives from the departments of Design and Construction, Health and Mental Hygiene and Education and the New York City Housing Authority also attended our workshops and provided invaluable feedback. Other participating organizations include the Real Estate Board of New York, Manhattan Solid Waste Advisory Board, Urban Green Council and Industrial Design Society of America’s NYC chapter.

How the Guidelines Came to Be

These guidelines grew from a question posed by Clare Miflin, architect at Kiss + Cathcart, Architects. While moderating an Urban Green panel on organics collection, she asked, “What can architects do to support organics collection in the buildings they design?” Panelists Christina Grace, CEO of Foodprint Group, and Brett Mons, then a senior program manager at DSNY, agreed the question was an excellent one.

Recognizing the gap between the work on waste handling and the work on building design, Miflin organized three roundtable discussions through the American Institute of Architects New York Committee on the Environment, with the help of its cochairs Pat Sapinsley and Ilana Judah. Representatives from DSNY attended these meetings, along with Foodprint Group’s Christina Grace, architects Jeff Miles and Elaine Zimmer, and Juliette Spertus and Ben Miller of ClosedLoops. The workshops generated a list of additional questions:

- How can materials best be moved through the building?
- Should we design our buildings with waste chutes?
- What should be done about cardboard?
- Can we avoid piling bags on the curb?
- Where can architects and developers get guidance on design requirements and recommendations for best managing waste?

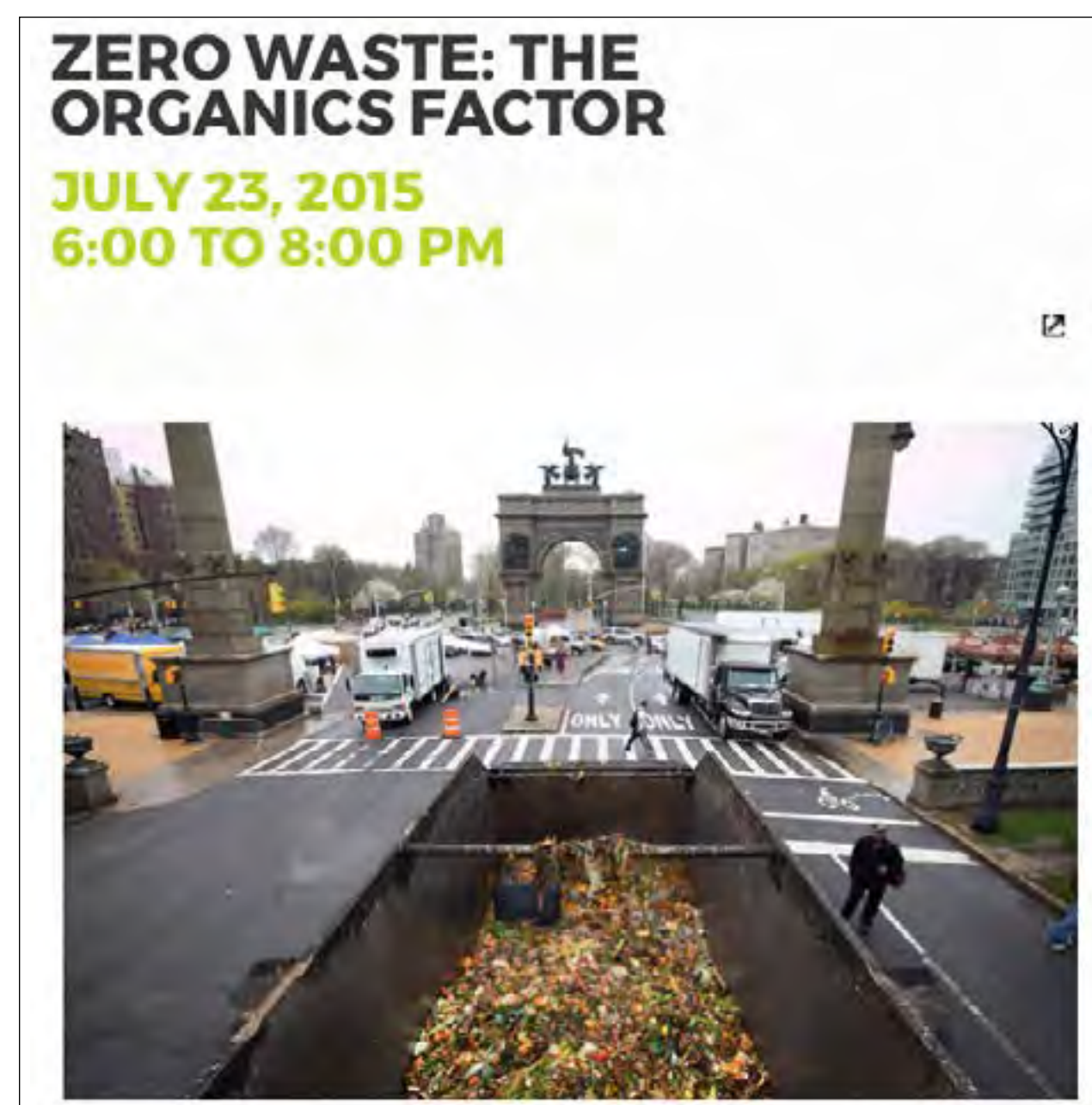

Urban Green Council panel on DSNY organics collection and implications for buildings

Building visits

The guidelines were created to answer these questions and others that emerged during the development process. They follow in the footsteps of other such interdisciplinary efforts as 2010's *Active Design Guidelines*, serving as both a set of practical recommendations and an inspiration for improving the quality of life in the built environment.

The guideline development process entailed visits to more than 40 building sites and conversations with porters and supers so we could understand their buildings' systems (see [Acknowledgments](#)).

Six collaborative workshops were involved:

- Scope-setting advisory committee workshop
- Multifamily residential building workshop
- Commercial and institutional building workshop
- Collection and urban issues workshop, and panel moderated by ClosedLoops' Ben Miller, with Elizabeth Balkan, Joseph Marano and Anthony Ardolino of DSNY, Claudia Herasme of DCP, Michelle Craven of DOT and Mike Reali of Royal Carting
- Construction and demolition roundtable (organized with Eunomia) moderated by Cole Rosengren of WasteDive with Ilana Judah of FXFowle, Naomi Cooper of Coopertank, Amanda Kaminsky of Building Product Ecosystems and Dominic Hogg of Eunomia
- Guidelines review and implementation workshop, and panel moderated by Clare Miflin, with Mark Chambers of MOS, Bridget Anderson of DSNY, Alison Novak of Hudson Companies, Stefan Knust of Ennead Architects and Christina Grace

The process also involved presentations at BuildingsNY, the Northeast Summit for a Sustainable Built Environment (with Adina Daar of Wildability), M-SWAB, GreenHomeNYC and DSNY Food Waste Fair, as well as to REBNY's board of directors.

A high point was a visit to the Queens Museum to view the "Maintenance Art" retrospective of work by Mierle Laderman Ukeles, DSNY's artist in residence. Her *Manifesto for Maintenance Art 1969!* laid out "the hidden yet essential role of maintenance in Western society—and the radical implications of actively valuing rather than dismissing or hiding it."



Collaborative workshops

The Rockefeller Foundation

Introduction

The Rockefeller Foundation is committed to halving the amount of food that goes to waste, which has reached crisis levels. As part of this commitment, we supported AIANY's *Zero Waste Design Guidelines*, which we hope will help cities—starting with New York, and soon others around the world—as they work toward a waste-free future. Though these guidelines aim to minimize waste of all types, our focus is on how approaches like these can play in addressing global food waste.

We produce enough food for everyone on the planet, yet too many lack proper nutrition because one-third of all food is never consumed. This wasted food also wastes all the precious natural resources that go into its production—like fresh water and farm land—and chokes our atmosphere with greenhouse gases as it languishes in landfills. Beyond the impacts on our planet, families lose hard-earned resources, too: in the United States alone, the average family of four spends \$2,000 every year on food they throw away.

Subtle changes in how buildings are envisioned and operated—which make it easier for occupants to change their own behaviors—can add up quickly and make a significant impact. We all have a role to play in cutting food waste, and new approaches to waste management can help us fulfill that responsibility.

We thank the AIANY team for leading this innovative work, and we look forward to more efforts that encourage sustainable living habits among consumers, residents, businesses, and communities worldwide.

Peter Madonia
Chief Operating Officer
The Rockefeller Foundation

American Institute of Architects

New York Introduction

“New York, let’s clean up New York!” scolded the gravelly voice of actor Danny Aiello. This popular public service announcement aired on TV and radio in the 1970s and ‘80s. The ad’s chiding tone reminded me, then a child growing up in the city, and other New Yorkers that it was our responsibility to keep New York clean.

Years later, while there may be less litter laying about and more trash receptacles on the city’s corners, streetscapes are dominated by waste: mountains of bagged trash, recycling blobs and cardboard box towers. With no alleys and no standardized requirements for on-site trash storage, New York’s sidewalks become barely navigable as ephemeral trash supertalls are routinely constructed and dismantled.

The *Zero Waste Design Guidelines* point out that waste is a design flaw. With that thought in mind, this report asserts that through design thinking, New York’s architects, government officials and citizens can solve our trash predicament.

The chapter has a long history of collaborating with the city on various guidelines that offer design solutions to improve spaces and lives. AIANY publications such as the *Aging in Place Guidelines for Building Owners* and the *Active Design Guidelines* have encouraged equitable, healthy and quality design for a broad range of New Yorkers.

AIA New York is proud to serve as the anchor institution for the development of the *Zero Waste Design Guidelines*. True to AIA New York’s core mission to serve its members, the project originated when a concerned architect asked the AIANY Committee on the Environment how she could design buildings that dealt with waste more effectively.

The process since then has been intense. Three meetings on the subject, held in 2015 and 2016, led to the transformative Rockefeller Foundation grant. We subsequently scaled up the project, hosting five public workshops at the Center for Architecture, which served to inform the content and research for the guidelines. An independent curator was hired to work with the committee throughout this process and produce a free and public exhibition on zero waste in 2018. The exhibition will be accompanied by a full-day symposium, evening panels and educational programming for New York City schoolchildren.

I am grateful to the large and dedicated team that brought this ambitious project to fruition, and I invite New Yorkers to once again join us as we clean up New York, this time with the new goal of achieving zero waste.

Benjamin Prosky, Assoc. AIA

Executive Director

AIA New York Chapter | Center for Architecture

NYC Mayor's Office of Sustainability Introduction

The Mayor's Office of Sustainability works every day to ensure New York City is the most sustainable big city in the world and a leader in the global fight against climate change. Achieving these goals require not only the collaboration of many City agencies, but also the support and collaboration of residents and professionals throughout New York City. These guidelines are the result of the hard work and commitment of dedicated New Yorkers to helping the City achieve its goal of sending zero waste to landfills by 2030 by ensuring that waste management, much like energy and water efficiency, are central to a building's design.

Better designed, more effective, and more intentional waste management is a necessary part of the City's effort to meet its climate goals. Decisions about waste management, however, aren't just about the emissions of greenhouse gases from the waste itself, but all the greenhouse gas emissions associated with the transport and handling of waste within the city, as well as the upstream impacts of packaging, deliveries, and freight. Better designed, more effective, and more intentional waste management also requires acknowledging the integral potential it has to improving a wide range of quality-of-life, public-safety, environmental, and economic issues.

The Mayor's Office of Sustainability is pleased to be working with city agencies, advocates, building design professionals, and communities to help achieve our OneNYC goals to make New York City more just, equitable, sustainable, and resilient.

The *Zero Waste Design Guidelines* are an important step forward in solving some of the interconnected and complicated challenges of waste management in our dense urban landscape. The Mayor's Office of Sustainability applauds AIA New York, the Center for Architecture, Kiss + Cathcart, Architects, Foodprint group, ClosedLoops, and The Rockefeller Foundation for their leadership in the development of these groundbreaking guidelines. We look forward to seeing how these guidelines help re-imagine possibilities for use and design of public and private space, and working with New Yorkers to turn these ideas into reality.

Mark Chambers

Director

NYC Mayor's Office of Sustainability

NYC Department of

Sanitation Introduction

The Department of Sanitation is pleased to participate in the creation of AIA's *Zero Waste Design Guidelines* to help reimagine waste management for the future of New York.

Our involvement in this effort marks a departure from the norm. Traditionally, DSNY and other City agencies have not been invited to the table or played a role in the upstream generation and management of waste. In order for us to get to our goal of Zero Waste to Landfills by 2030, this needs to change.

Waste management takes place in a complex system in which every element is directly interconnected, from source separation by the generator, to handling and storage within the building, set-out on the street, collection, transfer, transport, processing, and disposal. While there has been a widespread focus on the rules—what materials should be sorted for recycling and how the materials are processed at transfer facilities—there needs to be equal focus on proper infrastructure. Simple adjustments to make source separation more intuitive and enjoyable can have a significant impact on behaviors. With a holistic approach that solves challenges for building residents, managers and staff looking to do the right thing, we can reduce the economic and environmental costs of waste management, and the quality-of-life impacts to our public and private spaces.

With aging infrastructure and significant design challenges in our largely vertical city, we realize the scale of the task at hand. We applaud AIA and the team that participated in this process for their willingness to investigate, listen and think more broadly about waste management. DSNY looks forward to continuing to support this effort together with the other agencies who share responsibility for the functioning of our private and public spaces.

Kathryn Garcia
Commissioner
Department of Sanitation

How to Use the Guidelines

The *Zero Waste Design Guidelines* are based on the understanding that the design of our buildings and city is crucial in reaching zero waste goals. Although the geographic focus is NYC, many of the strategies presented may be transferable to other cities. The guidelines have been compiled as a tool for those responsible for planning, constructing and managing our buildings, streets and neighborhoods.

Waste management is poorly understood and not even considered by most designers, and waste managers and experts rarely get involved in design and planning. The built result is often a system full of friction, in which maintenance people create ad hoc solutions to compensate for the lack of design and foresight. The guidelines aim to educate designers and development teams about the role design can play in better managing waste materials—those discarded daily within our buildings and those stemming from the construction, renovation and demolition of the structures themselves. Well-designed waste collection systems can be viewed as an amenity that can be programmed into our buildings and public spaces. Design solutions range from macrolevel suggestions for circular material loops to microlevel details as the shape of container openings for waste in a recycling station.

The guidelines categorize waste-management operations by typologies—for particular building types—intended to help users identify opportunities relevant to their situation. An interactive

Waste Calculator approximates how much waste an individual building must plan for, under a variety of potential operating scenarios. Infographics illustrate maintenance operations, NYC regulations and other relevant considerations in spatial terms. Best practice strategies offer recommendations that are illustrated by case studies from NYC and beyond. While some of these best practices are possible now, others would require policy changes, which are covered in a later chapter.

The guidelines should be used as early as possible in the design process, ideally during programming and scoping. While new buildings can incorporate a greater array of strategies, existing buildings can often improve their systems considerably. The guidelines are best used as part of an integrative design process involving the entire team—clients, designers, contractors, operators—in setting goals and designing a system that maximizes the potential of achieving the city's zero waste objectives.

Executive Summary

Staten Island Transfer Station. Every day around 10,000 tons of refuse is collected by DSNY trucks and dumped at waste transfer stations. At this station 750 tons a day are loaded onto railcars to begin their journey to a South Carolina landfill.



Waste is a design flaw: in our packaging, in our products and in our buildings and cities. Ecosystems recycle materials indefinitely in circular loops, but the human-designed system discards 99% of the materials extracted from the earth within six months.¹ The *Zero Waste Design Guidelines* address the crucial role that the design of our buildings and city play in achieving zero waste.

Every day, tens of thousands of truckloads of materials—brand-new goods, clothes and food—enter our city to be parceled out in boxes, delivered urgently and consumed. Bags of discards line our streets, attracting vermin and monopolizing valuable public space. Thousands more heavy collection trucks take these materials to waste transfer stations, clogging the streets, polluting the air and degrading the quality of life in surrounding neighborhoods. Most of these materials are trucked to landfills in distant states, where they end up as trash, polluting the soil and air. This process costs New Yorkers over a billion dollars a year in taxes.² Through design, this system could be transformed. Discarded materials are a valuable resource that can be directly reused, fixed or recycled into new materials, compost and energy—while providing jobs within the city.

New York City has set a bold goal of sending zero waste to landfill by 2030. To achieve this, we need to design our buildings to better manage the movement of materials through them. Designing for material flows in our buildings is not the same as designing for energy and water flows. Materials are mainly moved by human labor, and they are not uniform—they can be useful, hazardous, recyclable or food for worms—so need

to be sorted to be used as resources rather than trashed. Zero waste requires an integrated approach with architects, planners and building operators working together to design a coherent system in which materials are easily separated, handled, stored and collected in their own streams.

The process of developing the *Zero Waste Design Guidelines* has been collaborative and extensive. It has involved visits to more than 40 buildings, discussions with porters and supers and the distillation of findings into typologies. Through multidisciplinary workshops, architects, planners, developers, city officials, building owners and operators helped develop and evaluate strategies for each typology, which the guidelines present.

Building Design: Planning for Separation, Movement and Storage of Waste in Our Buildings

Today's architects routinely strive to reduce embodied and ongoing energy and water usage in their designs. Similarly, they should design their buildings to reduce the ongoing waste that's generated and managed within them, as well as the waste from the construction and demolition process itself. Design can change human behavior and incorporate economic and social incentives for wasting less and recycling more.

As additional material streams such as organic waste, textiles and e-waste are collected, we need our buildings to facilitate their separation. In most buildings, trash disposal is top priority, which makes diverting other materials less convenient. Organics present new challenges: they're heavier than other recycling streams, they also decompose, thus need to be contain-erized, ventilated and collected more often.

Good design makes it easy to separate discarded materials for reuse and recycling. The waste calculator provided in the guidelines facilitates this by providing designers with a tool for calculating the volumes of all the streams that need to be captured and managed. Best practice strategies show how designers and building operators can plan for material flows through buildings by reducing wasted materials, separating waste streams and compacting them for easier transport and storage. They also show how to provide for efficient collection of the separated waste streams.

Collection and Urban Design: Planning for Waste Collection on Our Streets

The vast majority of our waste is moved out of our buildings in bags, stacked on sidewalks and tossed by hand into trucks. As their presence is temporary, city planners have traditionally left waste collection out of street design. Nonetheless, how bags are set out on and picked up from sidewalks and streets has a marked effect on the quality of urban life and the amount of waste diverted. As our city's density increases, this solution becomes less and less tenable.

Moving toward containerization, with its use of wheeled and large compacting containers, is one way to manage waste in public space—reducing the amount of precollection handling required and allowing for automated pickup. Many existing buildings lack adequate space for containers and access to equally convenient recycling and organics collection. Consolidating waste in facilities shared by buildings or neighborhoods could expand the adoption of best practices beyond new construction. Planners could incorporate this infrastructure into master plans, urban renewal projects and street design as an amenity.

Conclusion

Design has a crucial role to play in transforming our city, along with its systems and citizens, to reach zero waste. Design can compel us to change our behavior and consumption patterns so we reduce, share, reuse and assign space for managing discards so they too can be reused or recycled.

The *Zero Waste Design Guidelines* aim to serve as both inspiration and resource to help designers, operators and planners collaborate on modifying existing buildings and designing new ones that dramatically reduce our waste and work toward circular material flows. To lessen the significant friction in our current system, this necessarily iterative process will demand the commitment and creativity of a wide range of New Yorkers.

These guidelines embody OneNYC's goal: to be “the most sustainable big city in the world and a global leader in the fight against climate change.” Though drafted for New York, they were designed to be adaptable to other cities as well.

What is Zero Waste?

Zero waste is a visionary goal and a plan of action. The Zero Waste International Alliance (ZWIA) defines it as follows :

Zero Waste is a goal that is ethical, economical, efficient and visionary, to guide people in changing their lifestyles and practices to emulate sustainable natural cycles, where all discarded materials are designed to become resources for others to use.

ZWIA recognizes that this can't be achieved by simply changing waste management practices; changes must occur upstream, too:

Zero Waste means designing and managing products and processes to systematically avoid and eliminate the volume and toxicity of waste and materials, conserve and recover all resources, and not burn or bury them.

The goal is to stop all negative impacts of waste disposal to all living things:

Implementing Zero Waste will eliminate all discharges to land, water or air that are a threat to planetary, human, animal or plant health.

Aware of the ambitious nature of this goal, ZWIA recognizes zero waste communities and businesses as those that divert 90% of their waste from landfills, incinerators and the environment. ZWIA claims that zero waste programs are the fastest and most cost effective way for local governments to promote sustainability, reduce environmental impacts, protect health and create green jobs.

ZWIA recognizes that change must come on multiple levels: in industrial production and design; consumption, discard use and disposal within a community; and the political will to accomplish these goals. In the *Zero Waste Design Guidelines*, we focus on the role design can play in the second level— altering patterns of consumption, discard use and disposal.

Many cities in the United States and around the world have set zero waste goals, among them New York City, Dallas, Los Angeles, San Francisco, Vancouver, Buenos Aires, London, Milan, Paris and Tokyo. The plans may differ, but the overarching goal is to stop the relentless transformation of natural resources into garbage. Achieving this goal would go far in eliminating the many negative local and global consequences stemming from the current mismanagement of our life-sustaining material flows.

References

1. Paul Hawken, Amory Lovins and L. Hunter Lovins, *Natural Capitalism*, (New York: Little Brown and Company, 1999), 81.
2. Most Landfills that meet New York City criteria for long-term contracts are on average over 400 miles away. Department of Sanitation Budget was \$2.2 billion for fiscal year 2012. Citizens Budget Commission, "Taxes in, Garbage Out," 5/2012, 11, 2. https://cbcny.org/sites/default/files/REPORT_SolidWaste_053312012.pdf.

Context

19	Waste is a Design Flaw
26	How Did We Get Here?
31	How Can Design Help Us Change the System?
38	References

Waste is a Design Flaw

A lichen is made up of two organisms—an alga and a fungus. They can both live alone, but when conditions are tough they collaborate and become much more resilient. According to Robin Wall Kimmerer, botanist and author “In a world of scarcity, interconnection and mutual aid become critical for survival. So say the lichens.”



Increasingly, designers are considering opportunities unique to place, along with the broader consequences of their design decisions. Architects are designing buildings to conserve energy and water and take advantage of available sunlight and rainfall. Civil engineers and landscape architects are designing our sidewalks and tree pits so instead of overloading sewer systems, stormwater soaks back into the ground. Urban planners are designing inclusive public spaces that help forge social connections and lead to healthier, more resilient communities.¹ We can also design the built environment to support the stewardship of materials.

Every day, tens of thousands of trucks full of packages of food, clothing and other products enter New York City to be delivered, unpacked, and consumed. And every day, approximately 24,000 tons of discarded material leave the city as waste.² The consequences of this constant material flow through our streets and buildings are substantial: Trucks crowd our streets, creating air pollution, traffic accidents and climate change. The infrastructure that consolidates these materials for processing and disposal disproportionately affects disadvantaged neighborhoods, where asthma levels far exceed city averages.³

Since 1989, when NYC's first mandatory recycling law passed, a portion of the city's discards have been recycled. Some of this recycling takes place locally—notably, at the Pratt Industries paper plant on Staten Island—but the majority of these secondary commodities are sent to

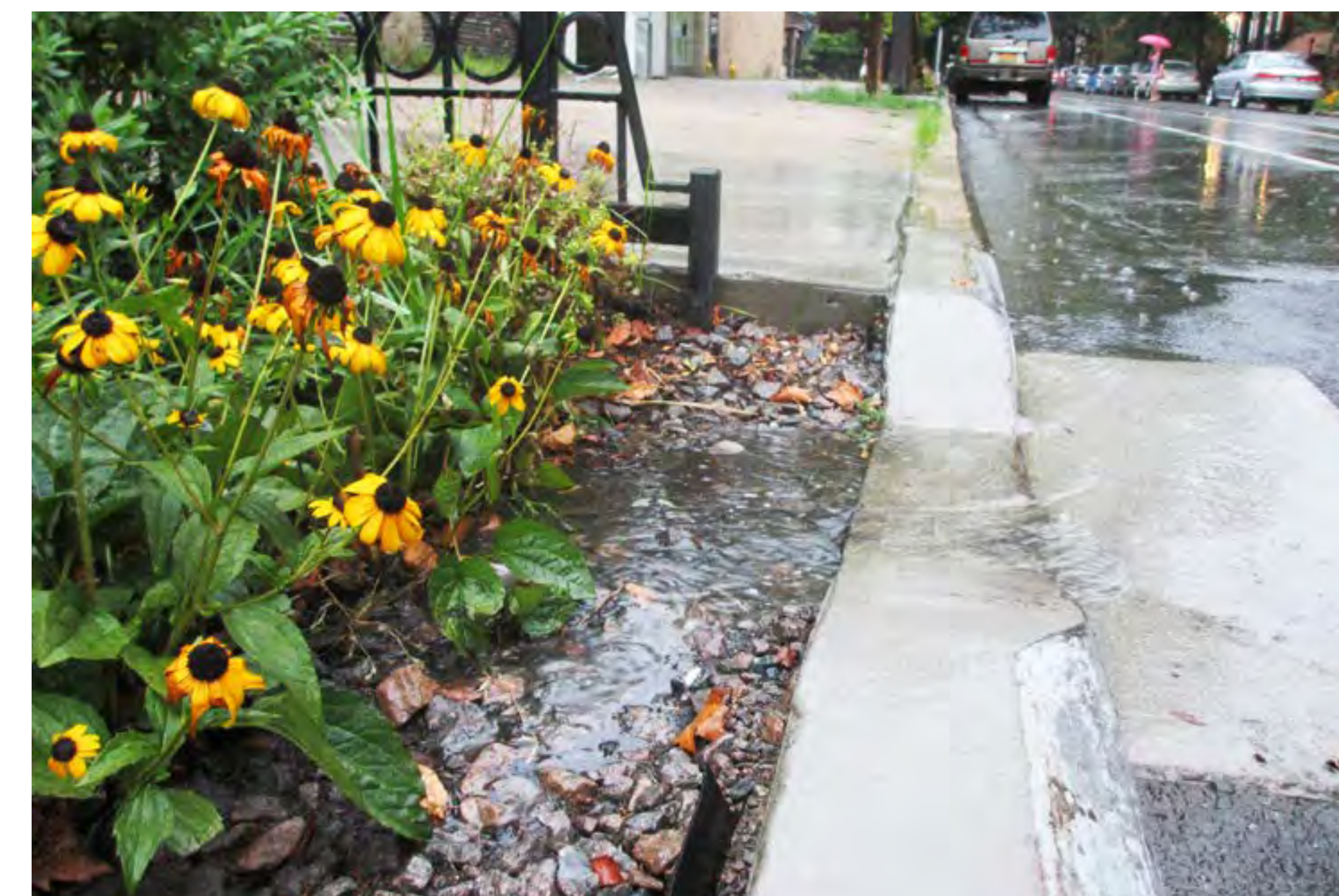

Clockwise from top: NYC Parks' Bushwick Inlet Park facility uses sunlight for electricity and the ground as a heat exchanger and collects rainwater for reuse; Herald Square, part of the DOT plaza program; DEP rain garden for stormwater infiltration

be processed hundreds or thousands of miles away. More recently, a fraction of the city's waste stream has been composted. Everything else, (about a third of which is organic), is trucked or shipped by rail an average 300 miles away,⁴ mainly to landfills but also to some



Containers being loaded onto railcars at the Staten Island Transfer Station for transport to a landfill in South Carolina

waste-to-energy incinerators. This disposal costs the city upwards of \$350 million a year.⁵ And for the next 20 or so years, the decomposition of the organic waste in the landfill will release methane, a greenhouse gas 30 times more potent than carbon dioxide.⁶

The upstream environmental consequences of extracting raw materials from fields, forests, mines and wells and turning them into products that are transported to our doors for consumption are vast. This process, which generates 60 times more waste than we throw into the bin,⁷ absorbs significant quantities of energy, water and human effort. The rare metals we need to constantly update our electronic



E-waste dumping in Ghana

devices are extracted from hazardous mines, often by children.⁸ Much of our clothing is produced in inhumane conditions to meet the rising demand for cheap, disposable fashion.⁹ This consumption disproportionately affects the global poor, whether through pollution, labor violations or climate change.¹⁰

Over the last 30 years, we have depleted a third of the earth's natural resources, and we're at risk of exhausting them entirely.¹¹ A recent United Nations report drew attention to a worldwide shortage of one of the most ubiquitous substances: sand.¹² Ever escalating development has consumed it in concrete, asphalt and base courses for buildings

and roads; sand is also used to make glass. In seeking more sources of raw materials, we have discovered that some landfills have a higher proportion of valuable and recoverable metals than do some ore deposits we're mining.¹³ European countries are starting to mine landfills, to recover metals, energy and the land itself.¹⁴ Couldn't we design a better system for using our finite resources?



Pratt Industries paper plant

OneNYC: New Goals

NYC's ambitious plan for the future, entitled "One New York: The Plan for a Strong and Just City," (2015) aims to move the city toward circular material loops.¹⁵ Expanding upon 2007's PlaNYC, the vision encompasses growth, equity, sustainability and resilience. The goals include having the best air quality among large US cities, reaching zero traffic fatalities, reducing greenhouse gas emissions by 80%, lifting 800,000 New Yorkers out of poverty, creating stronger communities and sending zero waste to landfills by 2030. To develop the goals cross agency working groups envisioned how reshaping the physical city could address a range of social, economic, and environmental challenges on the municipal and regional scale.¹⁶

NYC's Current Waste System: At the Macro Level

The diagram below gives us a view of the waste DSNY manages, which is residential waste as well as many institutions' waste. A similar amount of waste generated in commercial buildings is managed privately, but there is not enough reliable data to include it in the diagram.

Right now, we are far from zero waste. Although paper recycling and the separation of metal, glass and plastic (MGP) are mandatory, only about 50% of such materials are separated in our buildings. And although NYC has expanded its organics collection program to 2 million residents, only a small fraction of our organic waste is diverted.¹⁷

DSNY WASTE STREAM DIAGRAM

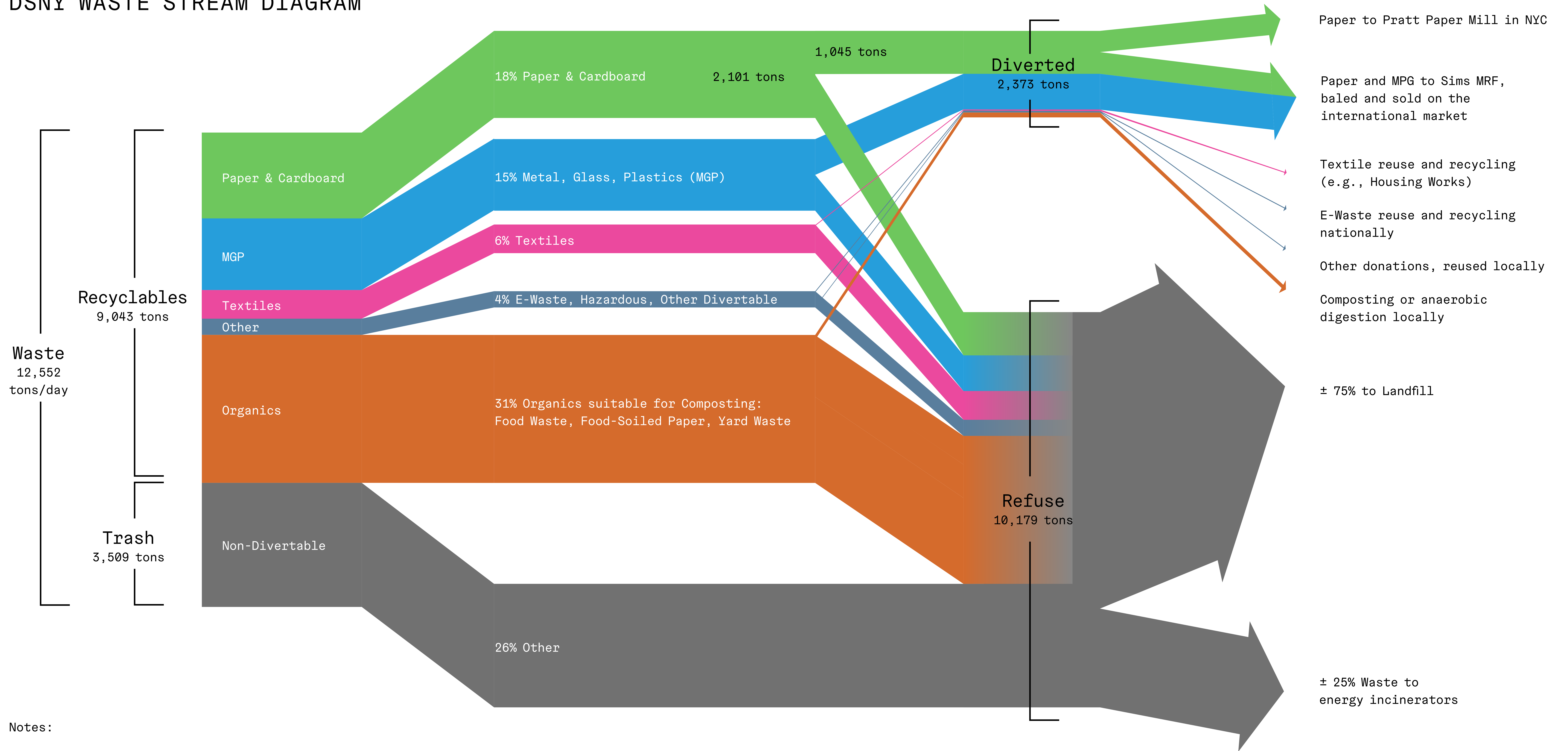

Notes:

Capture rate is the proportion of recyclables that get diverted, and is measured per waste stream—e.g., for Paper & Cardboard = $1,045/2,101 = 50\%$

Diversion rate is the proportion of the total waste stream that is diverted from disposal = $2,373/12,552 = 19\%$

Refuse is defined as the waste stream that gets disposed (ie sent to landfill or waste to energy incinerators)

As the diagram shows, there are various ways to reduce the volume of materials sent for disposal so that by 2030, the volume will be just 10% of the amount we landfilled in 2005. These include:

- Reducing waste generation, especially types of waste that can't be processed for reuse.
- Collection of additional recyclable materials—such as organics, textiles, bulk reuse and carpets.
- Increasing capture rates of recyclable materials so that more of each material stream gets diverted rather than disposed.

DSNY is developing policies to implement these approaches (see [Chapter 2](#)). Designing buildings to accommodate these policies will be critical to their success. Items that can be reused directly should not enter the waste system. Organics separation should be convenient and hygienic. Recyclable materials must be separated correctly and protected from weather, else they may end up in the landfill. Financial incentives must be passed on to individual households or businesses if behavior is to change.

NYC's Current Waste System: A Micro Level View

Rarely do architects have the opportunity to spend time in a finished building to see how well it works. In developing the guidelines, we talked with those who manage waste and followed its path from initial disposal to setout for collection; this allowed us to gain a micro level understanding of the process as it unfolds according to each building's unique circumstances.



Recyclables blocking egress corridor

We saw many buildings whose procedures for materials flow were lacking. Storage was inadequate and too far from the setout location, routes were circuitous, waste had to be set out in a tree pit or in front of the entrance, and the disposal of recycling and organics was far less convenient than trash disposal was. Some of these situations resulted from architects' oversights while others came from changes developers made during construction, to give more space to commercial tenants. We saw that these situations introduced points of friction into the system, frustrating workers daily and often leading to ad hoc suboptimal solutions, all of which reduced the diversion of designated recyclable streams.

Over the course of these visits, we noticed a common thread among successful buildings. When the whole team communicated—management, staff, occupants and haulers, DSNY and private alike—and members worked together creatively, problems were solved and all players felt engaged and motivated to improve the system. (See [StuyTown](#), [Strivers Gardens](#) and [Etsy](#) case studies.)

Many staff members remarked on the dramatic rise in the quantity of cardboard. When not neatly stacked or baled, it filled waste rooms or overflowed into corridors and blocked access to service areas and exits. We saw many buildings producing more waste than could reasonably fit on a sidewalk. We saw residential buildings managing their wastes well but observed that adding a separate organics collection would be a challenge, because the trash rooms were either too small or unventilated, or because staff would have to maintain many small containers and return them inside after collection. Clearly some things must change if the city is to reach its zero waste goals.

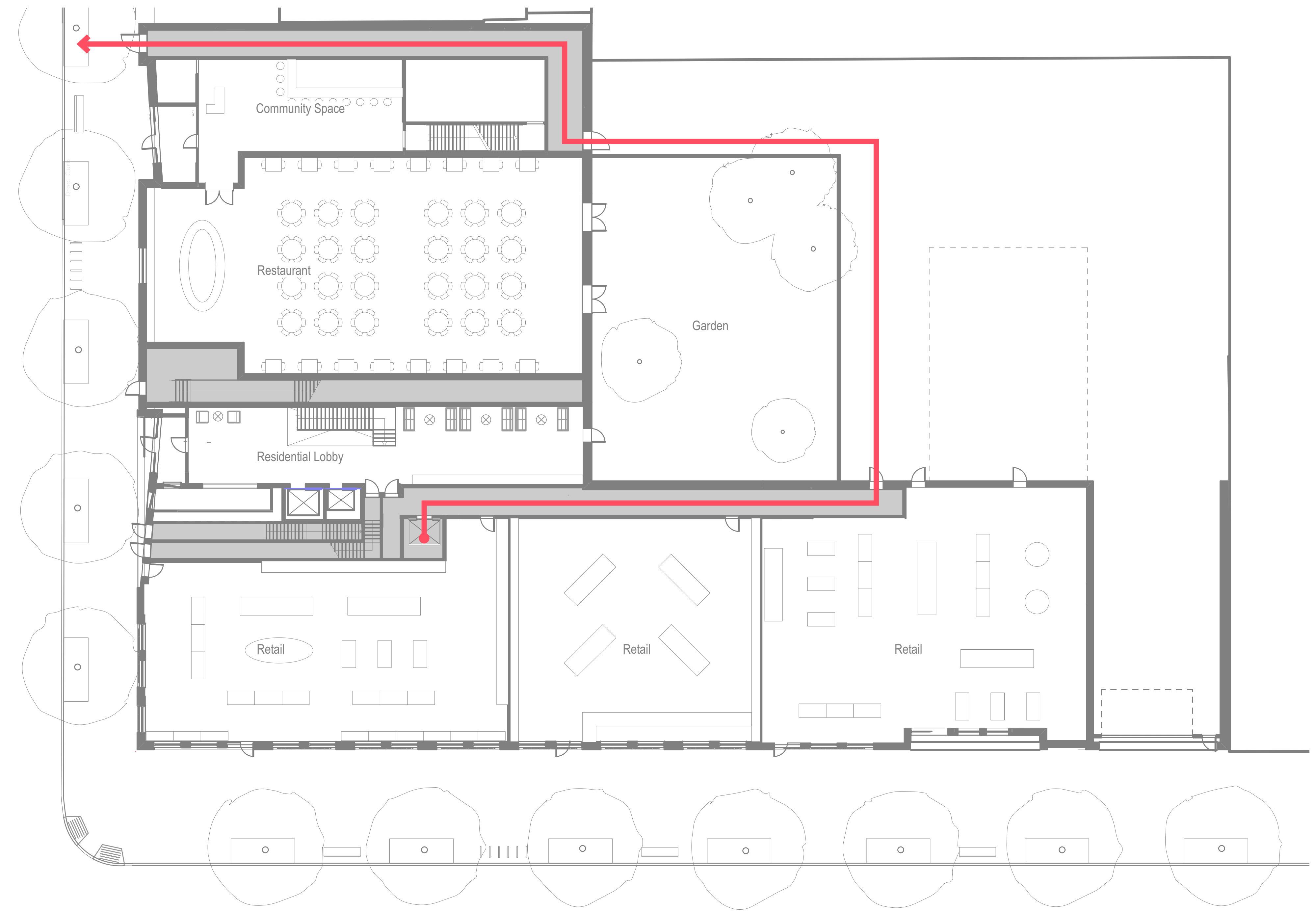

Example of a circuitous route for waste setout in the grey space of a plan

How Did We Get Here?

Ancient Anasazi pueblo
Canyon de Chelly



History, Sources and Trends in Material Flows

Early hunter-gatherers created no waste because all their discarded materials were natural. But even then, humans used their powers of design to make better tools.¹⁹ As societies developed, buildings evolved as products of our advancing design skills, but their forms and functions were strongly rooted in place. Local vernacular architecture illustrates this connection. As humans built cities, the density of habitation meant that wastes needed to be managed to reduce odors, vermin and disease. Ancient cities such as the Aztec empire's Tenochtitlán (now the site of Mexico City), population 200,000, recycled all its wastes within the city for productive reuse. Food waste was used in growing crops or fed to animals bred for consumption. Human waste was used as fertilizer, as well as to tan leather and fix fabric dyes. Combustible materials like textiles were burned to illuminate public spaces. There are no records of Aztec garbage dumps.²⁰

New York City's European founders were far less sophisticated in their management of materials. Most of their solid waste was thrown on the street and trampled into the manure left by the horses that formed the city's primary means of surface transport. If or when this waste was swept up, it was deposited in ponds, swamps and other low-lying areas or dumped into the harbor or the nearest river.²¹ The birth of the Department of Sanitation—in 1881, then called the Department of Street-Sweeping—was for sanitary and aesthetic purposes rather than for materials management. In the early 19th century, most of the organic waste—street-sweepings composed mainly of manure and straw—was

taken to Long Island fields, where it was used to fertilize fields so more hay would grow to supply the city's transport and dairy industries. At that time, most designed materials such as fabrics, ceramics and glassware were expensive, so they were repaired or used for other purposes. After scavengers had combed through the collected waste recovering metal, glass, buttons, rags, paper, bones and food scraps, what was left (mainly ashes) was dumped at sea.

After World War I (for which nitroglycerin extracted from NYC's refuse provided much of the firepower), new discoveries led to less costly ingredients for making fertilizer, soap and other goods, and complaints from neighbors led to the closure of the city's offensive "waste reduction factories." With their demise (and the 1934 Supreme Court-enforced cessation of ocean-dumping), wastes were incinerated or piled somewhere, such as on the shores of the Fresh Kills Creek, where the shell of the city's last waste-reduction plant still stands.²²

As the population grew in the late 19th century, so did the demand for natural materials like wood, metal, stone, bone and ivory. Human ingenuity led to the design of materials to replace those. Celluloid, the first synthetic polymer, was invented in 1869 as a substitute for ivory, which had become scarce with the increased popularity of billiards. Though celluloid didn't make for great billiard balls, it had many advantages over natural materials: It didn't get slimy when wet, like wood; it didn't crack like ivory; it didn't turn brittle like natural rubber; and it was easily colored.²³ What's more, it spared natural resources. According to the manufacturer, in 1878, "As petroleum



Early New York City sanitation cart dumping residual waste into the harbor

came to the relief of the whale, so has celluloid given the elephant, the tortoise and the coral insect a respite in their native haunts; and it will no longer be necessary to ransack the earth in pursuit of substances which are constantly growing scarcer.”²⁴

Bakelite, the first fully synthetic plastic, was invented in 1907 as a substitute for shellac, used for insulating the wires required as the United States rapidly electrified.²⁵ Electrification also changed the waste stream, which in 1918 was 75% ash but by the early 1920s included increasing amounts of packaging and disposable products,



Freshkills landfill on Staten Island opened in 1948 and by 1955 was the largest landfill in the world

chiefly made from paper.²⁶ Oil supplied the raw material to produce plastic on an industrial scale. It also drastically lowered the cost of transportation, allowing access to low-cost labor in distant places.

With World War II came huge increases in material demand, leading to rationing, the salvaging of household waste and a 300% increase in plastics production. After the war, the surplus industrial capacity was used to make products for the new postwar future of the 1950s, to keep the economy growing. Salvage was no longer needed and, in fact, actively discouraged.



World War II posters from the Office of War Information



Steam pressure vessel for making bakelite from Leo H. Baekeland's laboratory, 1909



Color chart for Bakelite, 1924

As Victor Lebow, a marketing consultant, stated, “Our enormously productive economy demands that we make consumption our way of life, that we convert the buying and use of goods into rituals, that we seek our spiritual satisfactions, our ego satisfactions, in consumption....We need things consumed, burned up, worn out, replaced and discarded at an ever increasing pace.”²⁷

The Aluminum Company of America (Alcoa) was one of the first companies to market a product designed to emphasize convenience over longevity. Ads for its single-use cooking containers asked consumers if they wanted

to avoid so-called fuss with washing. “Just throw out the dirty pan!” they exhorted.²⁸

A couple of decades later, when it seemed that the littering of the landscape would turn public opinion against excessive packaging, industry groups embraced the concept of recycling. Rather than interfering with the production of products and packaging materials upstream, recycling opened up another form of industry. Single-use packaging offered a means for companies to promote their product over others and became the primary method of communicating with consumers, as the large



Packaging from the 1950s and 1960s

new supermarkets had no shopkeepers to give advice. Single-use plastic beverage containers also eliminated the logistical costs to distributors of managing reusable bottles, thus strengthening the competitive advantage of large national companies over smaller local breweries and drinks producers.²⁹

Just as happened with product design, architecture embraced the possibilities of new materials in the postwar quest for modernity—a bright new utopian future, freed from the burdens of the past. The new architectural style was International, built to experiment with the new capabilities of materials: concrete, steel and glass.



United Nations Secretariat building by Oscar Niemeyer, Le Corbusier and others, completed in 1952, was the first skyscraper in NYC to use a curtain wall.

How Can Design Help Us Change the System?

Mushrooms are decomposers—they break down dead organic matter and return nutrients to the soil for new growth.



Our inventiveness and design skills have led us to an unsustainable linear system of cradle-to-grave consumption. These skills will also be essential in transforming our current system to one that considers our quality of life and that of all other species. This change will require us to broaden our outlook and deepen our understanding of the system.

The first in-depth attempt to understand the system of human consumption patterns in a world of finite resources was *Limits to Growth*.³⁰ One of the book's authors, Donella H. Meadows, was so discouraged by the lack of action in response to their findings, she spent the rest of her career exploring how to change systems. Such change requires what Meadows calls “dancing with systems,”³¹ an approach that involves observing at the big-picture level and the detailed level, staying humble and a learner, expanding time and thought horizons and attending to what is important, not just what is quantifiable. One of the most effective leverage points she identified was to change the goals of the system.³²

Designing for Material Flows

The goal of zero waste has been inspired by nature, whose materials are recycled in circular loops, in elegant and intricate designs that optimize resources. Many man-made materials such as aluminum, glass and gypsum wallboard can be recycled in perpetual loops too, but only if we design our materials, products and processes to allow for this. If our buildings and cities are designed so we can easily separate our cans and food scraps, then our landfills won't emit methane and we won't need to mine them later when there's no aluminum left.

An industrial system based on circular material loops and maximizing of assets, reuse and recycling is known as the circular economy, and leads to economic, environmental and social benefits.³³

Technical and biological (organic) materials are separated into two loops. The inner transformation loops—sharing, maintaining and reusing—use less energy and resources than the outer loops of refurbishing or recycling. These priorities align with those of the ‘waste hierarchy’.³⁴

Visualizing architecture's role in promoting circular material loops within a system can be done with a stock and flow diagram. In the center is the stock—for example, the amount of organic materials in the trash of a residential building. The goal is to decrease this stock, which can be done by reducing the flow of organic waste being discarded (left-hand side of the diagram) or by increasing the flow of organic waste to places other than the landfill (right-hand side). Factors that influence these material flows are added to the diagram, and those that an architect can influence are outlined in red. System diagrams can expand considerations, and other causal loop diagrams can identify factors with greater potential for system change. Two factors we determined were very important are the ease of transport through the building (how to manage material flows (see [Planning for Waste as a Material Flow](#)) and feedback loops that influence behavior. (See [BPS 2.11](#))

Designing a method to move discarded materials through a building requires knowledge of the materials' quantity and composition.

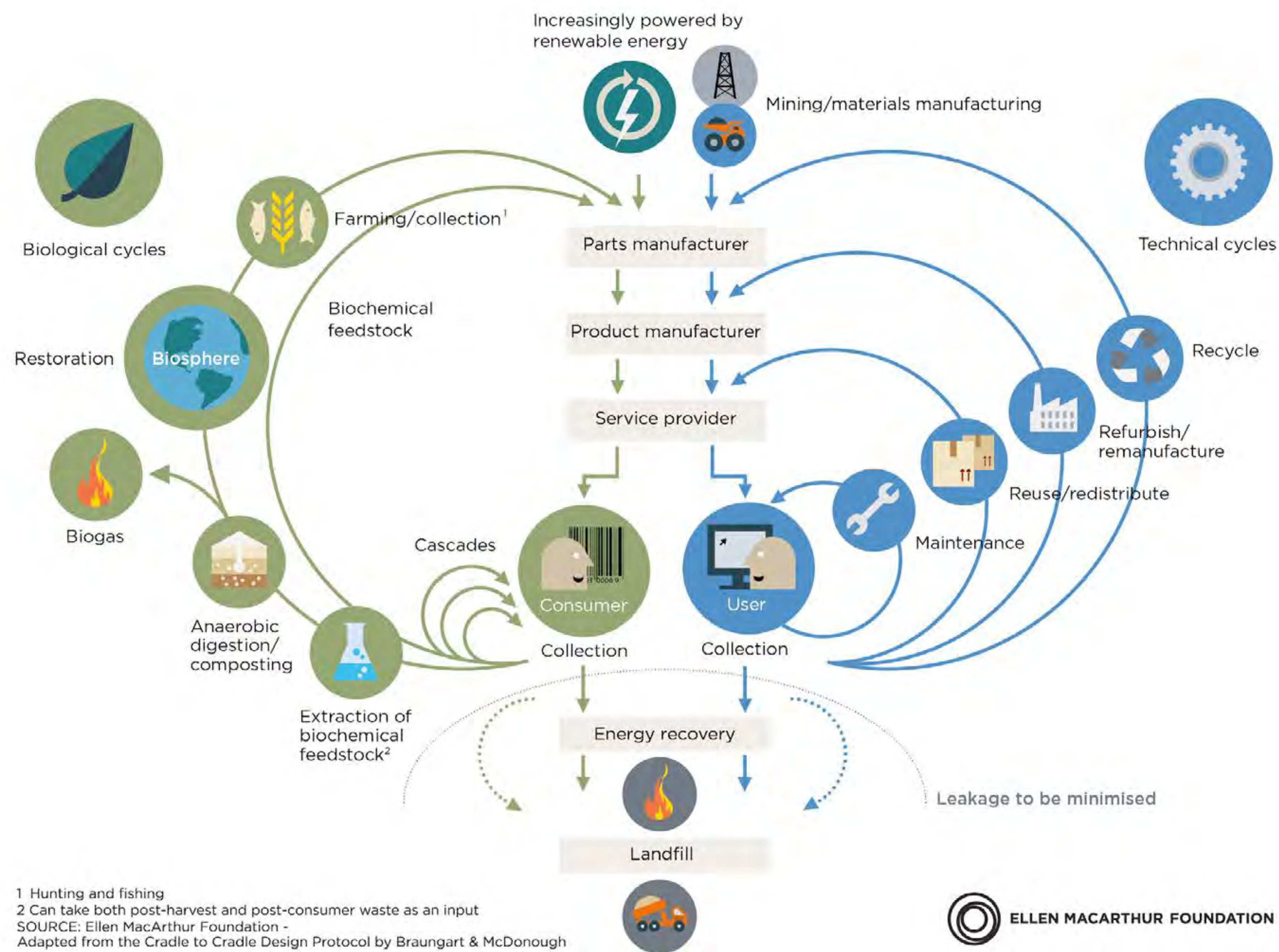

Circular Economy diagram

Most architects have no means of calculating this. How can one design for an unknown quantity of materials that need to be separated, stored and moved to the curb every day? These guidelines include a calculator that will give architects the ability to estimate the quantity of recycling, organics, textiles and trash they can expect in their building—and options for reducing the volume and transporting it—so that they can design for material flows.

Engineers specify the conduits and pipes that transport gas, electricity, and potable and waste water in and out of buildings, independent of human labor. Materials, however, are not uniform and are largely moved by hand. Decisions must be made every step of the way: Do I want this anymore? Which bin does it belong in? Where should I set out this bag? The materials are handled many times by different people before reaching the final processing or disposal location. The decisions are made in response to many factors and in many locations, not just in a waste room. We need to broaden the view of what designing for zero waste means, beyond a trash chute or a bin enclosure, to the whole building and even the neighborhood.

Architects need to consider not only occupants but also building staff and collection personnel, as the management of a building's materials is interwoven with the management of flows within the city. The design of waste setout in an isolated building has a powerful effect on the quality of life on the street, and the design of the street and sidewalk influence how waste is managed in a building. So designing a city for material flows requires an integrated approach, with architects, planners, developers, communities, waste haulers, reuse organizations and government agencies working together.

ORGANIC WASTE SYSTEM DIAGRAM

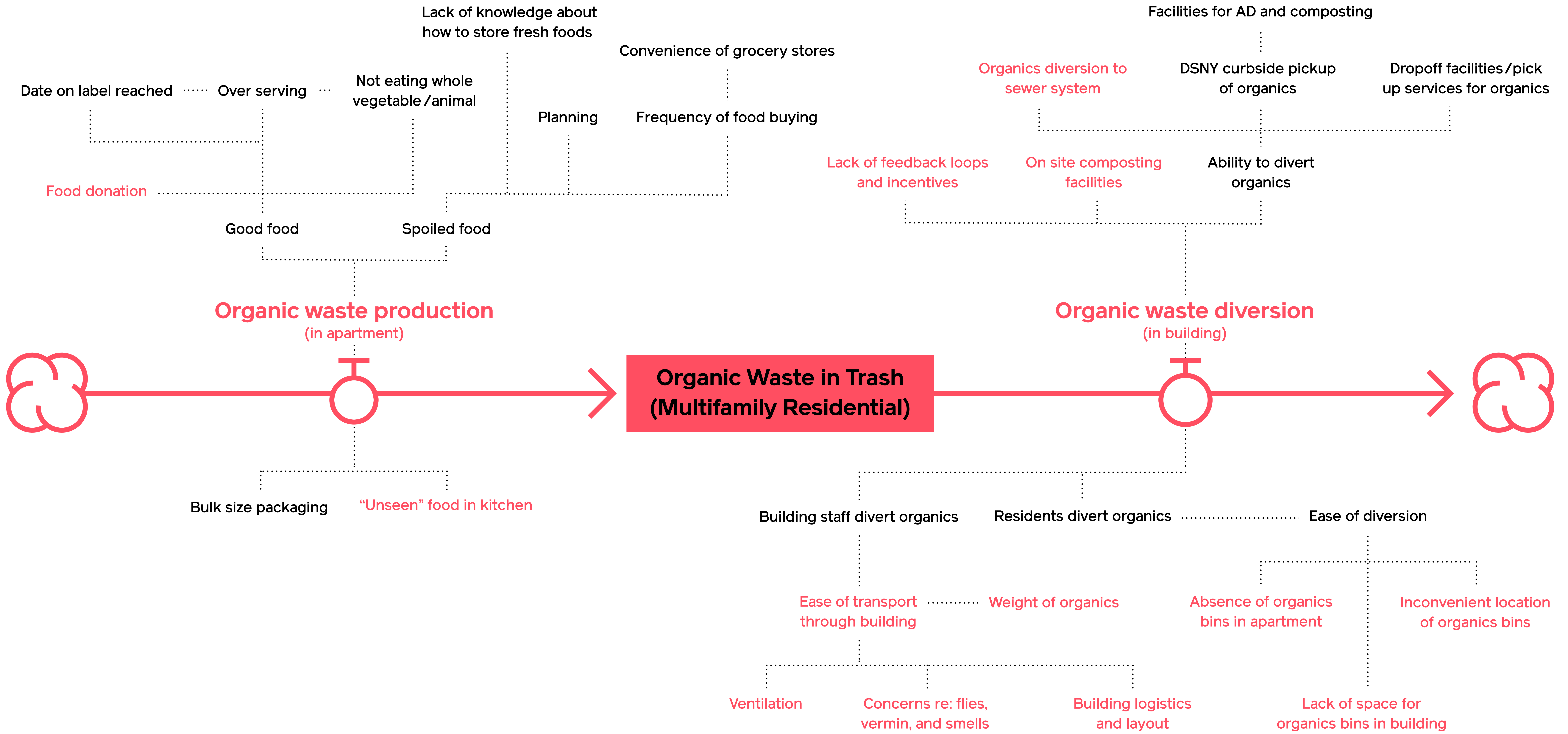



Decision points: Which bin does it belong in?

Learning from Ecosystem Change

By comparing the attributes that develop in nature as ecosystems mature into diverse, resilient systems with circular resources flows, we can gain insight into ways human systems can be designed to do the same.

Many species develop long-term mutually beneficial relationships, in which services are swapped for resources. For example, squirrels collect acorns, clean them, leaving their scent on them, before burying them in hundreds of locations, scatter hoarding them for the winter

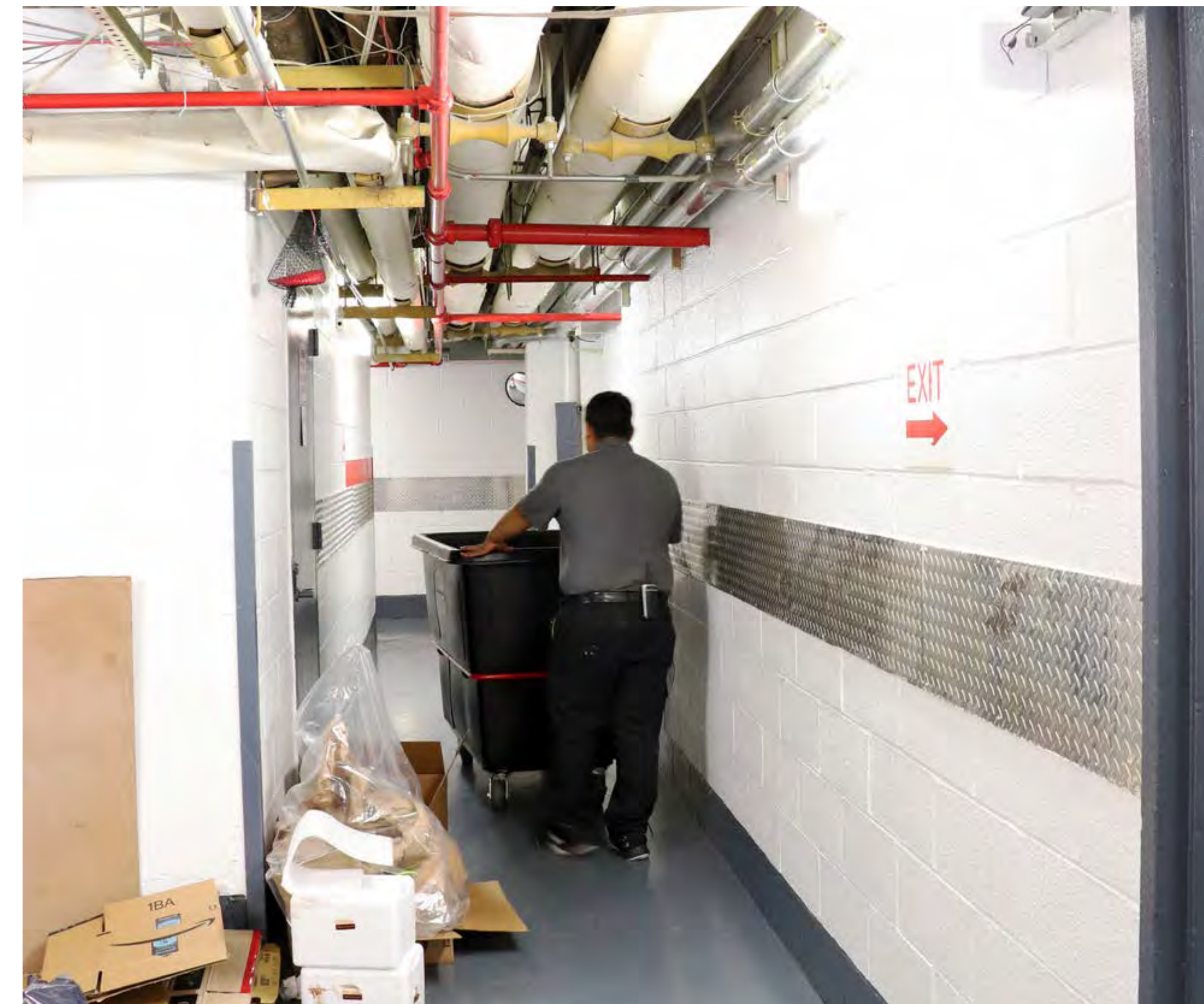

Staff pushing tilt truck through service corridor

months. When the squirrels don't find all the acorns, those that remain buried are well positioned to germinate, dispersing the oak trees' seed to new areas.

DSNY's partnership with Housing Works, called refashionNYC, is also a service-resource mutualism. The agency benefits because it is able to use fewer resources for refuse collection and disposal. Housing Works is able to collect more textiles for resale in its stores, and the profits fund housing and healthcare for HIV-positive people. Such win-win relationships help propel the waste system in the direction of circular material flows while reaping benefits for the city. More broadly, the rise of collaborative

consumption—explained by Rachel Botsman as “an economic model based on sharing, swapping, trading or renting products and services, enabling access over ownership”³⁵—slows down material flows through the efficient use of assets, resulting in less waste.

Niche specialization, or adaptation to fill a narrow role, is another characteristic that increases as ecosystems develop. BKRot, a composting group in the Bushwick neighborhood of Brooklyn is a specialist in NYC’s waste and social systems. The group finds vacant plots of land and employs local youth to collect food waste



Lichen is an example of a mutually beneficial relationship between alga and a fungus.

by bike, from restaurants and households. Waste is composted as the lots are transformed into community gardens and finished compost is sold in local stores and to neighbors and other gardens. Many successful companies participating in the collaborative economy are niche specialists, such as those that offer freelancers space to work in restaurants that are closed during the day.

Informational feedback loops become more prevalent as an ecosystem develops and act to balance the system. In NYC, electricity usage is always metered and is frequently submetered for individual units.



BKRot’s composting operation

Financial incentives and informational feedback have both been shown to change behavior, reducing energy usage.³⁶ Our waste system is woefully short on information and feedback loops, and developing these within our buildings could help balance our material flows.

Increasing opportunities for feedback loops, collaboration, social interaction and niche specialists can help transform NYC's system. Designing waste solutions at a community level, which capitalize on a neighborhood's unique characteristics, opens opportunities for collaboration that are otherwise unavailable at the city or individual building level (see [Punt Verd](#) and [Clichy-Batignolles](#) case studies).

The design of a city reflects and guides its citizens' aspirations. Transforming the city to reflect the goals of OneNYC will inspire New Yorkers to live in a way that helps reach them. If we design for pedestrians and cyclists, people will walk and bike. If we design for material flows, people will reduce their waste.

In her “Manifesto for Maintenance Art, 1969!” DSNY artist in residence Mierle Laderman Ukeles distinguishes between development—which she associates with separation and individuality; and maintenance—which she associates with unification and perpetuation of a family, city and the earth.³⁷ Ukeles merges art and maintenance in a collaborative, creative and cohesive process—one we need to bring into architecture as well. If we consider material flows as well as other natural resources, our buildings can weave together human and natural systems to ensure the future of our city.

References

1. For an example of planning public spaces to support social connections, see the research project announcement “Health, Equity and Public Space,” Gehl Institute, 8/28/2017; <http://gehlpeople.com/blog/health-equity-and-public-space/>.
2. New York City Independent Budget Office, “Ten Years After: Assessing Progress on the City’s Solid Waste Management Plan” (8/2017), <http://www.ibo.nyc.ny.us/iboreports/ten-years-after-assessing-progress-on-the-citys-solid-waste-management-plan-2017.pdf>.
3. Transform Don’t Trash NYC coalition, “Clearing the Air: How Reforming the Commercial Waste Sector Can Address Air Quality Issues in Environmental Justice Communities” (undated): 5, http://transformdonttrashnyc.org/wp-content/uploads/2016/09/Final-draft-v3_TDT-Air-Qual-Report_Clearing-the-Air-1.pdf.
4. Citizens Budget Commission, “Taxes In, Garbage Out” (5/2012), 11, https://cbcny.org/sites/default/files/REPORT_SolidWaste_053312012.pdf.
5. City of New York, “OneNYC: The Plan for a Strong and Just City,” 185, <https://onenyc.cityofnewyork.us/>.
6. United States Environmental Protection Agency, “Overview of Greenhouse Gases, Methane Emissions,” <https://www.epa.gov/ghgemissions/overview-greenhouse-gases#methane>.
7. Adam I. Davis, “Recycling the *New York Times Magazine* for Fun and Profit,” originally published in *Ecofables/Ecoscience* 1, no. 2 (Palo Alto: Stanford University Center for Conservation Biology, summer 1998), <https://web.stanford.edu/group/CCB/Pubs/Ecofablesdocs/recycling.htm>; for discussion of “gross national trash” from industrial processes relative to municipal solid waste, see Joel Makewers, “Two Steps Forward: Calculating the Gross National Trash,” in *GreenBiz* (3/20/2009), <https://www.greenbiz.com/blog/2009/03/20/calculating-gross-national-trash>.
8. Amnesty International, “This Is What We Die For: Human Rights Abuses in the Democratic Republic of the Congo Power the Global Trade in Cobalt” (1/2016), <https://www.amnesty.org/en/documents/afr62/3183/2016/en/>.
9. Human Rights Watch, “Work Faster or Get Out: Labor Rights Abuses in Cambodia’s Garment Industry” (2015), https://www.hrw.org/sites/default/files/reports/cambodia0315_ForUpload.pdf.
10. Stephane Hallegatte et al., “Shock Waves: Managing the Impacts of Climate Change on Poverty,” *Climate Change and Development Series* (Washington, DC: World Bank, 2016), <https://openknowledge.worldbank.org/handle/10986/22787>.
11. Organisation for Economic Co-operation and Development, *Material Resources, Productivity and the Environment* (Paris: OECD Publishing, 2/12/2015), 9, <http://dx.doi.org/10.1787/9789264190504-en>.
12. United Nations Environment Programme, “Sand, Rarer Than One Thinks” (3/2014), https://na.unep.net/geas/archive/pdfs/GEAS_Mar2014_Sand_Mining.pdf.
13. Nils Johansson, “Landfill Mining: Institutional challenges for the implementation of resource extraction from waste deposits,” dissertation (Linköping, Sweden: Linköping University Electronic Press, 2016) 23-24.
14. Nils Johansson, “Landfill Mining,” 21.
15. “Through these steps, New York City will become a global leader in the movement to develop a ‘circular economy’ where resources are used again and again, rather than mined from the earth and dumped into landfills.” “OneNYC,” 180.
16. “OneNYC,” 14.
17. DSNY Press Release, 7/3/2017, <http://www1.nyc.gov/assets/dsny/about/press-releases/pr2017/07032017.shtml>.
18. For an example of the effects of contamination on opportunities for recycling, see Will Flower, “What Operation Green Fence Has Meant for Recycling,” in *Waste 360* (2/10/2016), <http://www.waste360.com/business/what-operation-green-fence-has-meant-recycling>.
19. Combs were one of the earliest human tools, according to Susan Freinkel, “A Brief History of Plastic’s Conquest of the World,” in *Scientific American* (5/29/2011), <https://www.scientificamerican.com/article/a-brief-history-of-plastic-world-conquest/>.
20. <https://ourworld.unu.edu/en/the-aztecs-of-mexico-a-zero-waste-society>.
21. Benjamin Miller, *Fat of the Land: Garbage in New York, the Last Two Hundred Years* (New York: Basic Books, 2000), 17-80.

22. Miller, *Fat of the Land*, 17-80.
23. Nicole Shukin, *Animal Capital: Rendering Life in Biopolitical Times*, (Minneapolis: University of Minnesota Press, 2009).
24. Freinkel, "A Brief History."
25. Freinkel, "A Brief History."
26. Heather Rogers, *Gone Tomorrow: The Hidden Life of Garbage*, (New York: The New Press, 2005), 65.
27. Rogers, *Gone Tomorrow*, 114.
28. Rogers, *Gone Tomorrow*, 116.
29. Rogers, *Gone Tomorrow*, 136.
30. Donella Meadows et al., *Limits to Growth: A Report for the Club of Rome's Project on the Predicament of Mankind* (New York: Universe Books, 1972).
31. Donella Meadows, "The Dance," Donella Meadows Archives (undated), <http://donellameadows.org/archives/dancing-with-systems/>.
32. Donalla Meadows, "Leverage Points: Places to Intervene in the System," The Sustainability Institute (1999), http://donellameadows.org/wp-content/userfiles/Leverage_Points.pdf.
33. Ellen Macarthur Foundation, "What Is a Circular Economy?" <https://www.ellenmacarthurfoundation.org/circular-economy>.
34. Waste hierarchy, in order: prevention, minimization, reuse, recycle, energy recovery and disposal.
35. Rachel Bostman, "The Sharing Economy Lacks a Shared Definition," in Fast Company (11/21/13), <https://www.fastcompany.com/3022028/the-sharing-economy-lacks-a-shared-definition>.
36. Raanan Gerberer, "Submetering Your Building's Electricity: Paying for What You Use," in The New York Cooperator (9/2011). <https://cooperator.com/article/submetering-your-buildings-electricity/full>.
37. Mierle Laderman Ukeles, *Manifesto for Maintenance Art 1969!* http://www.feldmangallery.com/media/pdfs/Ukeles_MANIFESTO.pdf.

Building Design

41	Residential Building Context
63	Commercial Building Context
80	Institutional Building Context
84	Residential, Commercial & Institutional Best Practice Strategies
122	Construction & Demolition Waste Context
130	Construction & Demolition Waste Best Practice Strategies
137	Building Design Case Studies
173	References

Residential Building Context

A chute door for trash disposal and some bins for recycling within a small unventilated room. This is the typical situation for most NYC multifamily residential buildings. Adding an organics bin is a challenge.



Residential Waste Stream

In 2016, DSNY collected an average of 12,550 tons of waste per day. Of this, 18.9% was diverted from disposal in landfills or incinerators.

The piechart shows the composition of the waste that DSNY collects from residences and institutions. Reaching zero waste requires the following complementary approaches:

- Reducing waste generation
- Increasing capture rates for all diverted streams
- Diverting more of the waste stream through new diversion streams such as organics and textiles

DSNY is developing policies for these approaches, and the design and layout of our buildings needs to accommodate them.

OneNYC Initiatives

Reducing Waste Generation and Increasing Capture Rates Through Save as You Throw

From 2005 to 2016, the total volume of trash collected by DSNY was reduced by 11%, but the pace of reduction must increase dramatically to meet the 2030 OneNYC target of 90% reduction from the 2005 baseline. One path to greater reduction could be a Save as You Throw (SAYT) initiative, which DSNY is currently considering. SAYT financially rewards those who waste less and recycle more. OneNYC estimates

that implementing the SAYT program could reduce refuse generation by as much as 30%. Whether buildings are designed to pass this financial incentive on to the individual household will be critical to the success of a SAYT program.

Increasing Capture Rates Through Single-Stream Recycling

Capture rates for traditional recycling streams (paper, cardboard and metal, glass and plastic [MGP]) are around 50%, so there is much improvement to be made. Collecting these streams together—in what is called a single stream—may decrease the value of some waste streams, and separation is dependent on the sorting technology at a materials recovery facility. Other large U.S. cities that have moved to single-stream recycling have seen improvements in capturing recycling streams and reducing mileage on collection trucks. Starting in 2020, DSNY plans to collect single-stream recycling, which will affect waste management within buildings.

Additional Diverted Materials: Organics, Textiles and E-waste

Organic waste—food scraps, food-soiled paper and yard waste—composes almost one-third of the waste DSNY collects; when handled properly, it's a valuable resource. NYC has the largest curbside organic program in the country, collecting organics curbside in certain neighborhoods as well as from enrolled buildings and drop-off sites. By 2018, all buildings will either have curbside organic pickup or convenient access to organics drop-off. In time, this program will be mandatory, so buildings need to plan for organic waste diversion.

DSNY WASTE STREAM COMPOSITION

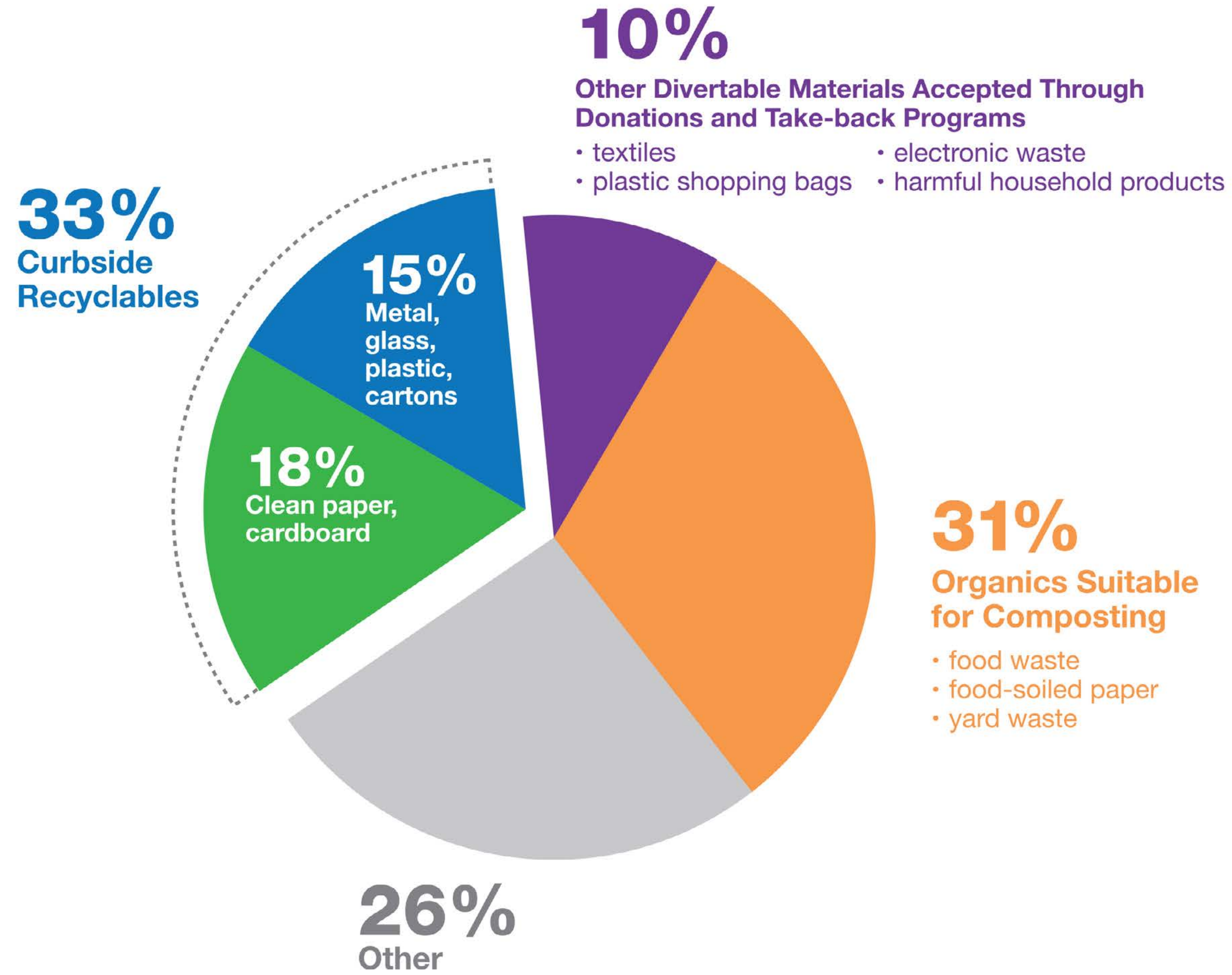

Data is taken from DSNY 2013 Waste Characterization Study

DSNY's refashionNYC program, a partnership with Housing Works, provides and services textile bins. Buildings of ten or more units can apply for these bins, which are often kept in laundry rooms or other communal areas; Housing Works empties them when they're full.

Electronic waste (e-waste) is no longer permitted in the curbside waste stream because of its toxic components and to promote its special recycling. DSNY's ecycleNYC program offers e-waste pickup to buildings of ten or more units and citywide drop-off events allow for convenient disposal of electronics and other hazardous household waste such as chemicals and household drugs. Provision for e-waste storage within buildings helps residents separate this toxic waste stream, which is the largest and fastest-growing component of hazardous waste sent to landfills.

The Changing Waste Stream

The rise in delivery services, which increased the use of cardboard, has dramatically altered residential waste-stream characterizations. Cardboard not sent down chutes must be broken down; its volume can be reduced with baling equipment. The material is also a valuable stream with a market for reuse, and designers need to plan for more of it.

Other waste-stream changes include a decrease in paper and an increase in nonrecyclable food-delivery cold packs and insulation.



Organics and textiles at GreenMarket drop off and household hazardous waste and e-waste from DSNY SAFE event

Seasonal Waste Trends

Waste is generated inconsistently throughout the year:

Predictable cycles align with seasonal changes and holidays.

DSNY makes provisions to collect special seasonal waste streams such as fall leaves and Christmas trees.

Rules and Standards

For sources see [Building Rules & Standards](#) in the Appendix.

DSNY Rules

See [NYC Rules for Setout](#).

DSNY regulates collection of garbage for curbside setout.

- Buildings to have receptacles to contain waste generated in 72-hour period.
- Trash goes into heavy-duty opaque bags or bins with lids (less than 44 gal. and 60 lb. for handling ease).
- Recyclable materials must be placed in clear bags (13–55 gal.) or clearly marked containers (18–32 gal.), or cardboard and newspaper can be tied in bundles under 18 inches high.
- Recyclable-material storage areas of four-plus-unit buildings need signage.
- Organics go into a DSNY-supplied organics bin (16 or 22 gal.) or DSNY-approved bin (fewer than 35 gal.).
- Time for receptacle setout is either between 4 p.m. and 9 a.m. or 4 p.m. for daytime pickup.



Residential buildings are receiving an increasing volume of deliveries.



Christmas tree collection



Typical residential set out for DSNY collection

DSNY regulates collection of containerized garbage.

- Roll-on/roll-off 20–35 cu yd containerized collection is possible and can be compacted for trash and paper, or in open containers for paper and cardboard, MGP, and bulk waste.
- Currently 1–8 cu yd EZ-Paks are only picked up from buildings with an agreement in place.

DSNY regulates garbage separation streams.

- Recycling categories: Currently, the separation of MGP, paper and cardboard from trash is mandated; organics will likely be mandated in time.

- Some items, such as certain regulated electronic equipment and hazardous substances, cannot be placed in the trash or recycled. (See [DSNY](#).)
- Some items—such as appliances, mattresses and seasonal yard waste—require special handling. (See [DSNY](#).)

Building Code Requirements

BC 1213.1 General

- Mandates compliance with MDL #81 and HMC 27-2021 and requires a refuse or recycling storage rooms, the location of which shall be identified on construction documents. The storage space needs to be a minimum of 1.5 sf/dwelling unit or 350 sf (whichever is less). If there is a compactor, the amount is 1.0 sf/dwelling unit or 350 sf in addition to the equipment and circulation space for the compactor.
- If interior, the storage space needs to be 2-hour fire rated.
- If exterior, an additional 4 sf is needed and shouldn't be on public right-of-way.
- If there is a chute with mechanical system to transport materials directly off-site (pneumatic or similar), then storage is not required.

BC 1213.2 Compactor

- States that a refuse compacting system shall be provided for I-1 or R-2 occupancy multiple dwellings 4 or more stories in height and containing 12 or more dwelling units and any R-1 occupancy multiple dwellings.

- Such system needs to be located within a refuse storage room constructed in accordance with BC 1213.1 or in a refuse chute termination room constructed in accordance with BC 707.13.4 (3-hour fire rated).
- The room shall have a concrete floor sloped to a floor drain and a hose connection.

BC 1213.3 Chute

- States that a multiple dwelling 5 or more stories in height and that contains more than 9 dwelling units shall be provided with a refuse chute, refuse chute access rooms, and refuse chute termination room constructed in accordance with Section 707.13.
- Provision needs to be made for recycling (5 sf) in the refuse chute access room, unless there is a chute for recycling or a chute that has system for separating recycling.

Multiple Dwelling Law

Section 81 states that proper receptacles for garbage need to be provided and garbage needs to be removed daily.

Housing Maintenance Code Requirements

Section 27-2021 states requirements for waste receptacles, storage rooms and collection of waste matter. These requirements are also mostly covered in DSNYRR and BC.

Zoning Resolution Requirements

Zoning Resolution (ZR) allows some deductions from floor area for provision for waste management:

- ZR 13-32 allows exemption of up to 300 sf for dumpster storage adjacent to loading dock in buildings over 100,000sf in the Manhattan Core (minimum dimensions 12' x 25').
- ZR 28-12 quality housing developments can deduct 12 sf per trash room.

ZR has some requirements for refuse storage provisions:

- ZR 26-16 requires a central refuse storage area within the zoning lot for residences in high-density R9 and R10 districts. Minimum area is 75 sf (for uncompressed garbage) or 50 sf (for compressed garbage) per 10,000 sf of lot area.
- ZR 28-12 Quality Housing buildings are to provide refuse storage at rate of 2.9 cu ft per dwelling unit. A refuse disposal room minimum 12 sf to be provided on each story with dwelling units.

LEED v4 Credits

LEED offers credits for materials and waste management including prerequisites for Storage and Collection of Recyclables, and Construction and Demolition Waste Management Planning. (See [LEED v4 Waste Management Credits](#) in the Appendix.)

Enterprise Green Communities Criteria with NYC Overlay

Enterprise Green Communities Criteria is a nationwide green building criteria list designed for affordable multifamily housing. New York City's Housing and Preservation Department (HPD), which requires that projects follow it, has an overlay which makes some of the credits mandatory. Credit 6.13 for Recycling Storage (mandatory per NYC overlay) requires separate bins for collection of trash and recycling for each dwelling unit and shared community rooms. For multi-family buildings, a permanent dedicated indoor area for collection and storage of recycling materials is required.



Converted chute with a compactor replacing the former incinerator.

Residential Typologies

Before the 1970s, many larger multifamily buildings had trash chutes emptying into cellar incinerators. Air-quality concerns led to the banning of these incinerators, and the chutes were then connected to compactors instead. Such converted chutes, typically smaller than later chutes, were often located directly in a corridor rather than in a small trash room. NYC housing stock ranges from one- to three-family homes with bins in the front yard to highly serviced doorman buildings with separate circulation and elevators for waste collection to high-rise residential towers with multiple chutes for different waste streams.

Although the building stock varies physically in many ways, sometimes including ground-floor commercial spaces, the management of residential waste within buildings can be categorized by six typologies. The method of collecting the waste is not directly related to the management within the building, and it is categorized independently as Truck Collection Typologies in Chapter 3.

Each residential typology is described separately and assessed in terms of:

- Space required: Space efficiency is desirable to building owners, especially on floors above grade.
- Labor required: Labor in moving waste adds costs for building owners.
- Convenience to resident: Most residents want convenience.
- Cost and maintenance: Some typologies require equipment, which adds capital costs and requires additional maintenance.

These four concerns are interrelated—and additional convenience to the resident will generally result in increased labor costs. Similarly, equipment such as chute sorters will reduce labor but increase capital costs and maintenance requirements.

Additional considerations relate to the best practice strategies in chapter 3, and the typologies are assessed in terms of how easily they can accommodate them:

- Volume reduction: Compaction leads to reduced volumes and area required for storage and setout of waste.
- Equal convenience disposal: This is the ease of adding organics collection with co-located bins.
- Save as You Throw (SAYT) rewards: Can they be easily passed back from building to resident to incentivize waste reduction and increased recycling?

Of the six building typologies, Typologies 1, 2 and 3 are not permitted by [NYC Building Code](#) for new buildings with more than five stories and nine units because of the requirement for a chute and chute access room. For a new building, the choice would be between Typologies 4, 5 and 6. This decision is a balance between the considerations listed above.

Typology 4, which provides equal convenience disposal of all waste streams including organics, is the best choice. It does require well-ventilated waste rooms and staff to service the bins daily.

Typology 5 and 6 are also options, but organics chutes are not common, especially in NYC where DSNY does not pick up from 1–2 cu yd containers. If organics come down a chute into a wheeled bin or turntable system, they have to be serviced frequently. Organics chutes also need more washdowns. (See [Grand Millennium case study](#).) Private carter service could be chosen, with the organics chute emptying into a 2 cu yd container (a tighter connection requiring less frequent servicing).

Typology 1 is a good option, requiring a lower level of service without the issue of organics chutes; it is common internationally in multifamily residential buildings. A pilot building of this residential typology in NYC could provide valuable insight into whether a code change should be considered. (See [Chapter 4](#).)

RESIDENTIAL TYPOLOGIES

1. Central Location
2. Service Corridor
3. Corridor Chute with Central Recycling
4. Trash Room with Chute and Bins
5. Single Chute with Sorter
6. Multiple Chutes



TPOLOGY 1: CENTRAL LOCATION



In the simplest scenario, residents bring waste to a central waste area. The area may be interior (at grade level or in the cellar) or exterior (in front of the building within the property line, on the sidewalk or in a side yard).

Though not allowed by code for buildings over five stories and nine units in NYC, central at-grade waste rooms located directly off the lobby are very common internationally in multifamily buildings. (See [Clichy-Batignolles case study](#).)

Advantages

- Space efficiency: Floor area not needed on every story
- Low labor for maintenance staff (however, if the central waste area is not large enough, extra labor may be required to move waste to another storage space before setout)

Disadvantages

- Inconvenient for residents who can't routinely carry waste out
- Alignment with best practice strategies
- Volume reduction: Typically used with wheeled bins and no compaction in existing NYC buildings, it can be used with compaction—for example, if disposal into waste inlets could direct waste into compactors below.
- Equal convenience disposal: This allows for co-location of trash and recycling and organics, if in a well-ventilated location.
- SAYT: The rewards could be bag-based per resident, with enforcement via camera possibly required.

Notes

- Disposing of waste in a publically visible location may increase diversion.¹
- Moving bins to the exterior can remove odors and pests from the interior but be detrimental to the quality of the sidewalk experience. Exterior bin enclosures also require capital costs and maintenance.



Left:
Limited room for interior
and exterior storage
in Chinatown tenement

Below:
Central storage in cellar
and on street



TPOLOGY 2: SERVICE CORRIDOR

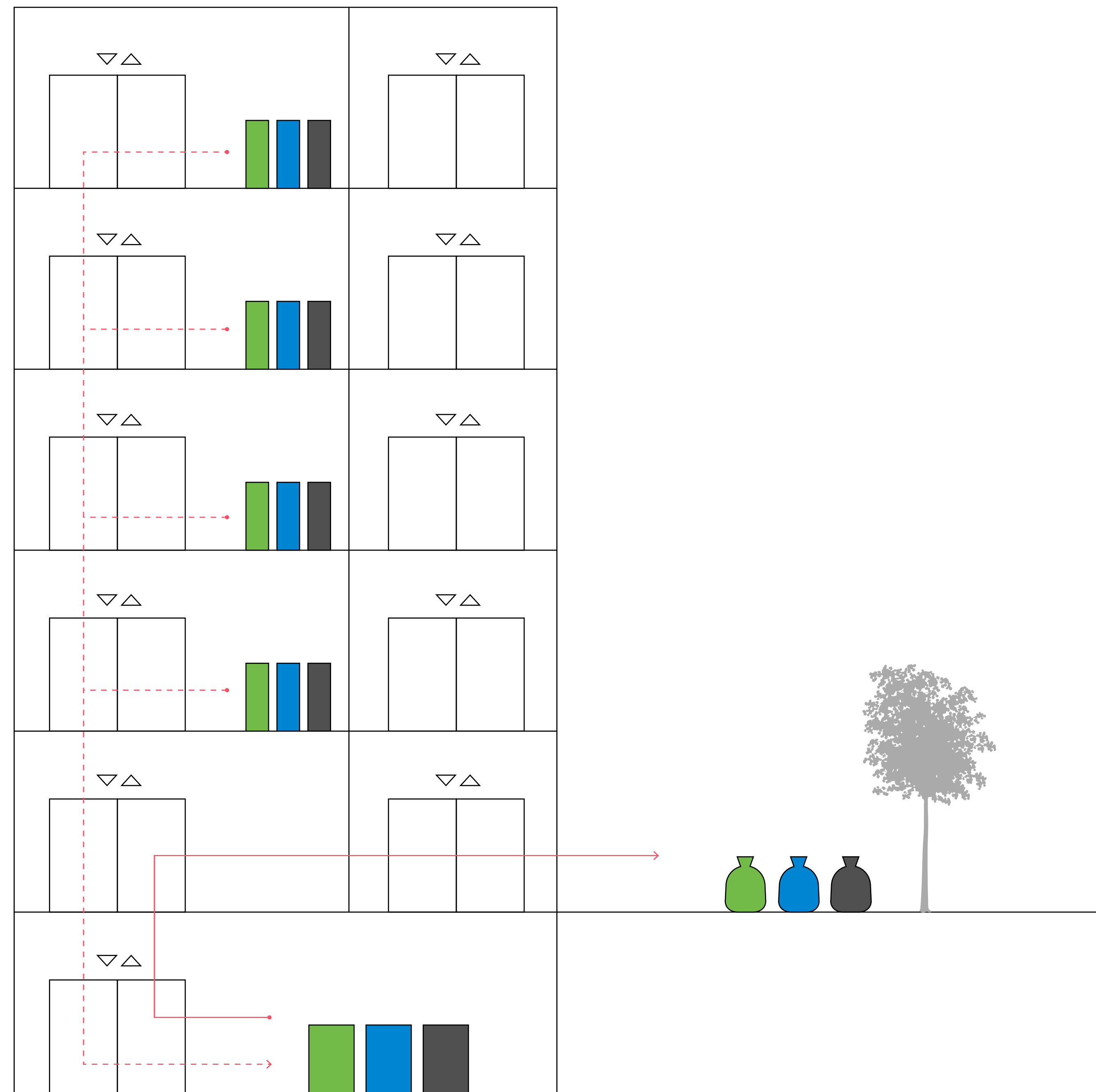

Typically found on the Upper West and East sides of Manhattan, these are large apartment buildings, often cooperatives, with doormen and staff who service the building through its separate service circulation. Residents generally place their waste in bins or bags, as well as bundled cardboard, directly outside the service door to their apartment.

Advantages

- High convenience

Disadvantages

- Requires separate service corridors.
- High labor, as waste is picked up from outside every apartment.

Notes

- Volume reduction: Typically there is no provision for compaction, though a central compactor could be used.
- Equal convenience disposal: There is co-location of trash and recycling, and it should be easy to add organics as waste is usually removed often.
- SAYT: The rewards could be bag or container based per resident; enforcement would be easy, as waste is collected door to door.

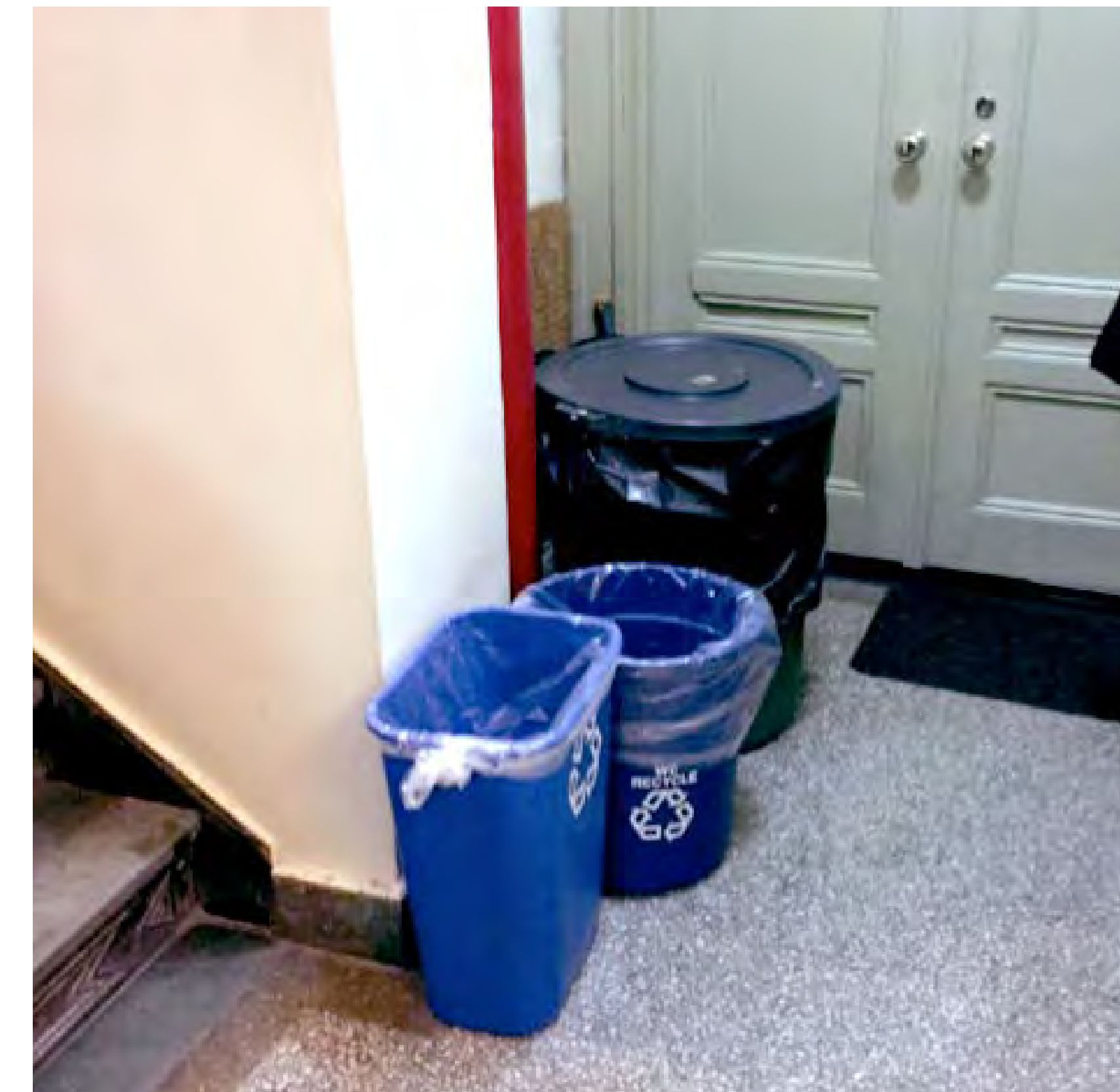

Waste left by residents outside of the apartment service door.

TPOLOGY 3: CORRIDOR CHUTE WITH CENTRAL RECYCLING



Typically found in larger apartment complexes or New York City Housing Authority (NYCHA) housing, this system often consists of a narrow chute that previously emptied into an incinerator. The chute door is in the egress corridor, or alongside the elevator, making it against code to add co-located bins for recycling or organics. Recycling is located in a central area.

Advantages

- Space efficient: Floor area is not needed on every story.
- Low labor: Waste streams are collected from only two locations.

Disadvantages

- Trash disposal is convenient for residents, but recycling disposal is not, prioritizing trash over recyclable streams.

Alignment with best practice strategies

- Volume reductions: Trash typically empties into a compactor.
- Equal convenience disposal: Co-location of trash and recycling is not possible; organics can typically be added beside the central recycling.
- SAYT: The rewards could be bag-based per resident, monitored with a camera facing the chute door, or savings from a container based system could be passed on to residents through use of a digital key to open the chute door.²

Notes

- Chutes with adequate space for a sorting system can be retrofitted, allowing residents to dispose of all waste streams down the chute.



Chute door in residential corridors and central recycling station



TPOLOGY 4: TRASH ROOM WITH CHUTE AND BINS



This is the most common provision for NYC's multifamily buildings. Trash goes down the chute to a compactor, and MGP and paper recycling is put in bins in the trash room. Sometimes there is also space for cardboard, or there may be another designated area. The trash room is often small and unventilated with just enough space for small recycling bins.

Advantages

- Convenient for residents

Disadvantages

- Space required on every story as well as labor to collect recyclables.

Alignment with best practice strategies

- Volume reduction: Trash is typically emptied into a compactor.
- Equal convenience disposal: Co-location of trash and recycling and organics is possible with a large well-ventilated waste room serviced daily (often not the case in existing buildings).
- SAYT: The rewards could be bag-based per resident, monitored with a camera facing the chute door, or savings from a container-based system could be passed on to residents through use of a digital key to open the chute door.³

Notes

- There are floor area deductions for housing developed under the Quality Housing rules of NYC Zoning Resolution, but complying with American Disabilities Act requires trash rooms to be much larger than the allowable 12 sf deduction.



Waste rooms are typically small and unventilated, with chute access and recycling bins; Trash chute connected to compactors with “sausage” bags.

TPOLOGY 5: SINGLE CHUTE WITH SORTER

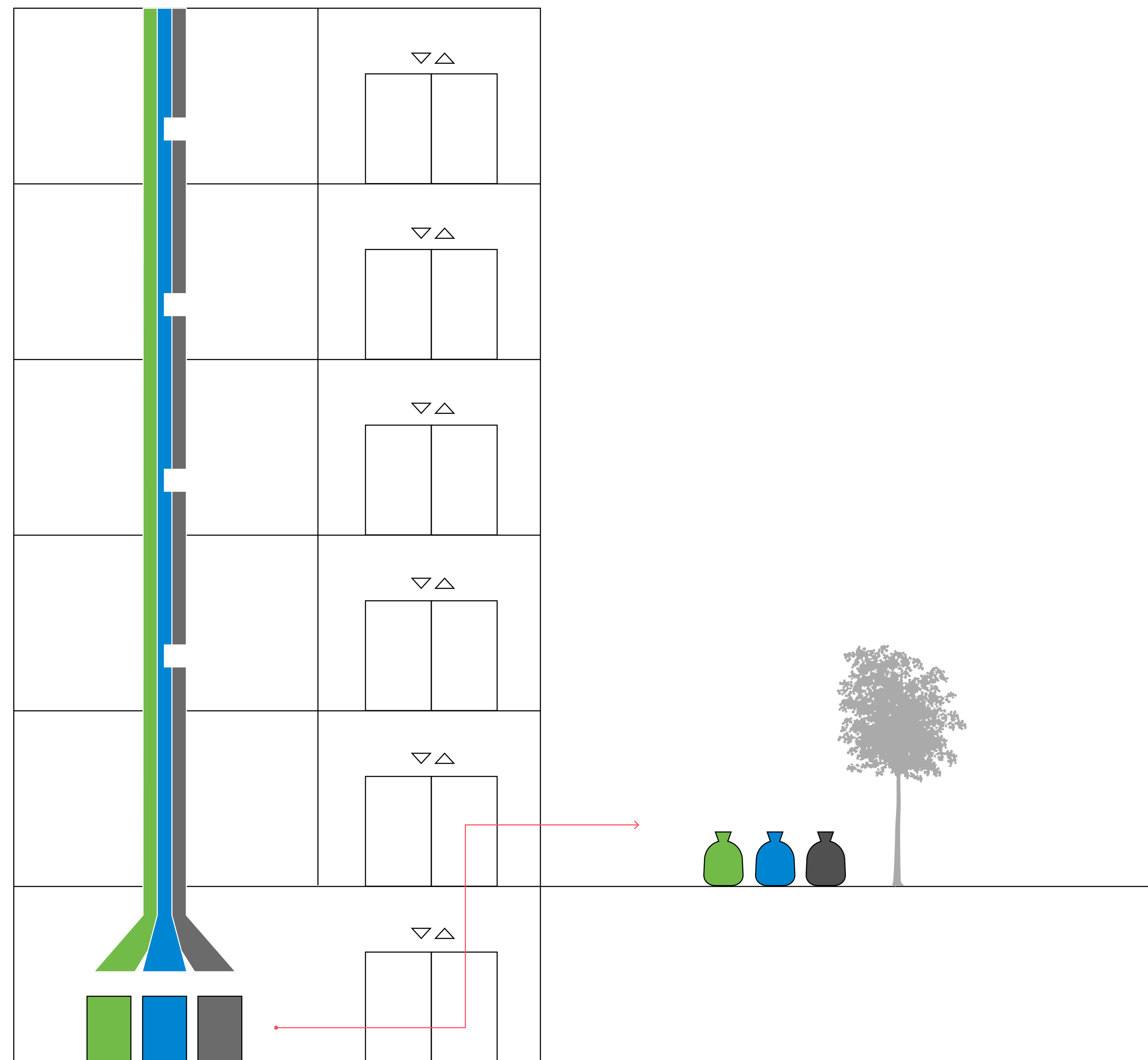

Sorter systems allow use of a single chute for multiple waste streams. See [Chute Options](#). Before opening the chute door, residents press a button to choose the waste stream. The sorting equipment directs the trash into a compactor and the recycling streams into containers. The building code requires a chute access room (for buildings over 5 stories and 9 units), even though no storage space is required for recyclables. See code section above.

Advantages

- Low labor: Convenient location for disposal of all streams

Disadvantages

- Learning curve to operate equipment properly
- Wait time while another resident uses the system
- Higher capital costs, with equipment requiring regular maintenance

Alignment with best practice strategies

- Volume reduction: Trash typically empties into a compactor, and some systems allow for compaction of other streams.
- Equal convenience disposal: Co-location of trash and recycling and organics is possible, depending on the number of streams the sorting system allows for.
- SAYT: The rewards could be bag-based per resident, monitored with a camera facing the chute door or savings from a container-based system could be passed on to residents through use of a digital key to open the chute door.⁴

Notes

- This typology, suitable for buildings with fewer units and buildings without high turnover since new residents need to learn to operate the system, reduces wait time.
- There can be flexibility for future streams—for instance, a bisorter to a compactor and a turntable with multiple bins. (See [Grand Millennium case study](#).) A trisorter does not allow for flexibility to add streams, though chute designation could be changed.



Simple 3 button control panel for trisorter; Chute to tri-sorter



Control panel for residents to select waste streams for bisorter and turntable; Chute to bi-sorter with compactor and turntable

TPOLOGY 6: MULTIPLE CHUTES



Multiple chutes allow for co-located disposal of multiple waste streams without mechanized sorting systems. (See [Chute Options](#).) Typically residents enter a trash room with three chutes: one leading to a compactor, one for MGP and another for paper. Cardboard must be left in the trash room or taken to a central location. There are variations on this setup: Some buildings may collect glass separately within the trash room while other buildings have just trash and MGP chutes and collect paper and cardboard separately in a recycling bin.

Advantages

- Low labor; High convenience

Disadvantages

- If glass needs to go down the chute, super-heavy-duty bags must be used to prevent staff injury (a nonissue if the chute connects directly to a container).
- Additional area on every floor is required, and the chute area itself counts as zoning floor area per the NYC Zoning Resolution.⁵

Alignment with best practice strategies

- Volume reduction: Trash typically empties into a compactor.
- Equal convenience disposal: Co-location of trash and recycling and organics is possible, depending on the number of chutes provided.
- SAYT: The rewards could be bag-based per resident, monitored with a camera facing the chute door, or savings from a container-based system could be passed on to residents through use of a digital key to open the chute door.⁶

Notes

- Inflexibility to add or reduce streams to reflect future DSNY policies (though chute designation could be changed).
- This system works better if chutes connect directly to larger containers— 1–2 cu yd—rather than bags in wheeled bins because it requires less service and eliminates hazardous broken glass in bags. Some buildings with this typology have changed from DSNY collection to private collection so they could use 2 cu yd containers at the base of the chutes. (See [Avalon case study](#).)



Three separate chute doors for trash, MGP and paper



Two chute doors for trash and single stream recycling (private hauler collection)



Trash chute empties into a compactor; MGP and paper chutes empty into tilt trucks

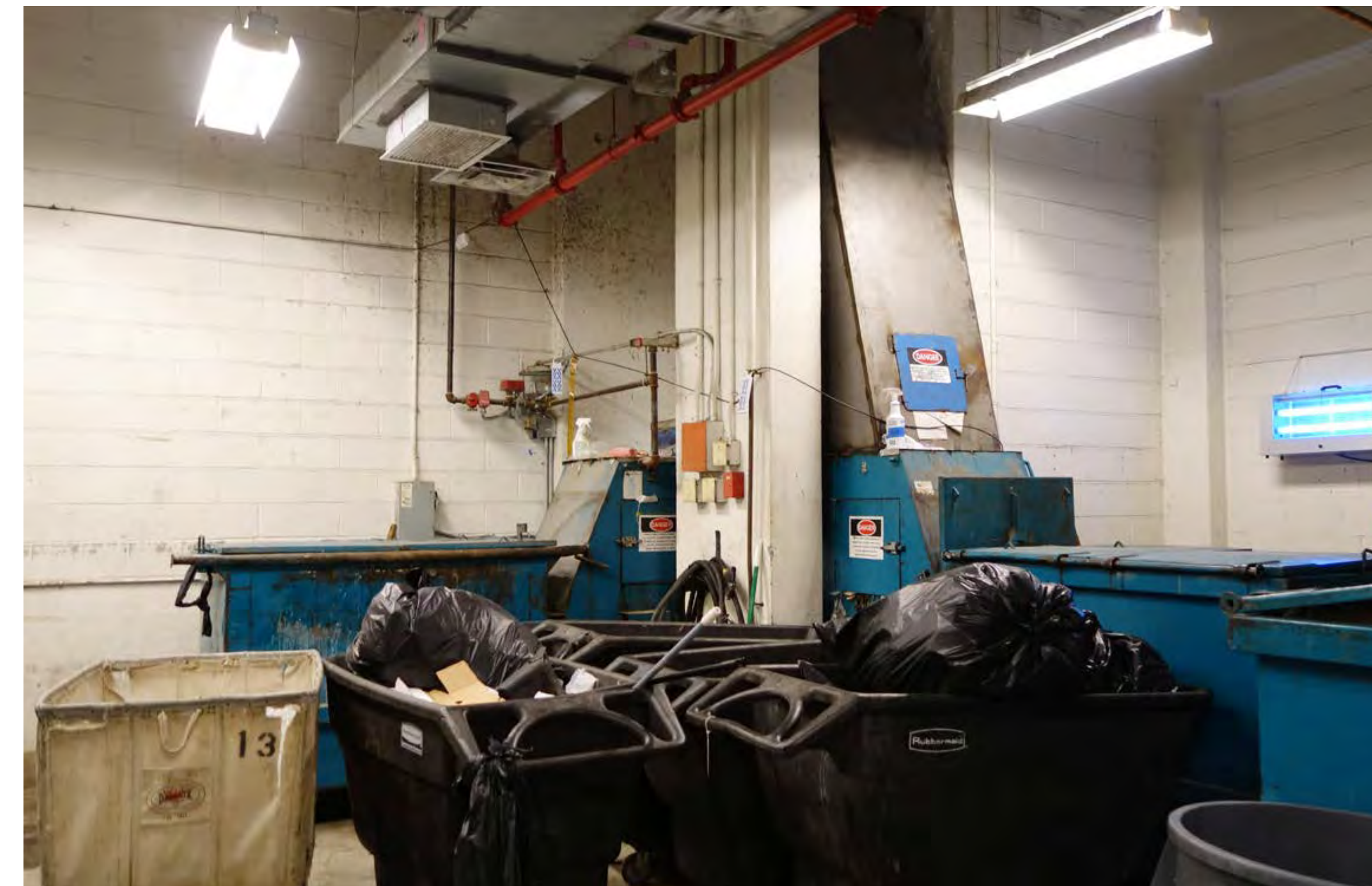

Trash and recycling empty into compactors and 2 cu yd containers

RESIDENTIAL BUILDING DESIGN CONSIDERATIONS

1. Waste room: consider area, ventilation, lighting, signage. 2.03, 2.10
2. Chute and disposal of recycling on every floor required by BC 1213.3 ≥ 5 stories and ≥ 9 units)
3. Consider how waste travels vertically (by chute, by residents or by building staff in regular/service elevator). 2.02
4. Provide co-location disposal for all waste streams including organics. Consider other waste streams that may block chutes, e.g., cardboard, textiles, hangers. 2.08
5. Trash compactor required by BC 1213.2 for ≥ 4 stories and ≥ 12 units
6. Consider path of waste to curb and staff time required. 2.02, 2.05
7. Waste storage room per BC 1213.1 or BC 707.13.4. Use containers unless room is ratproof and fireproof room per HMC 27-2021. Consider area required, ventilation, and washing of containers. 2.01, 2.03
8. Compost can be made and used on-site in gardens. 2.23

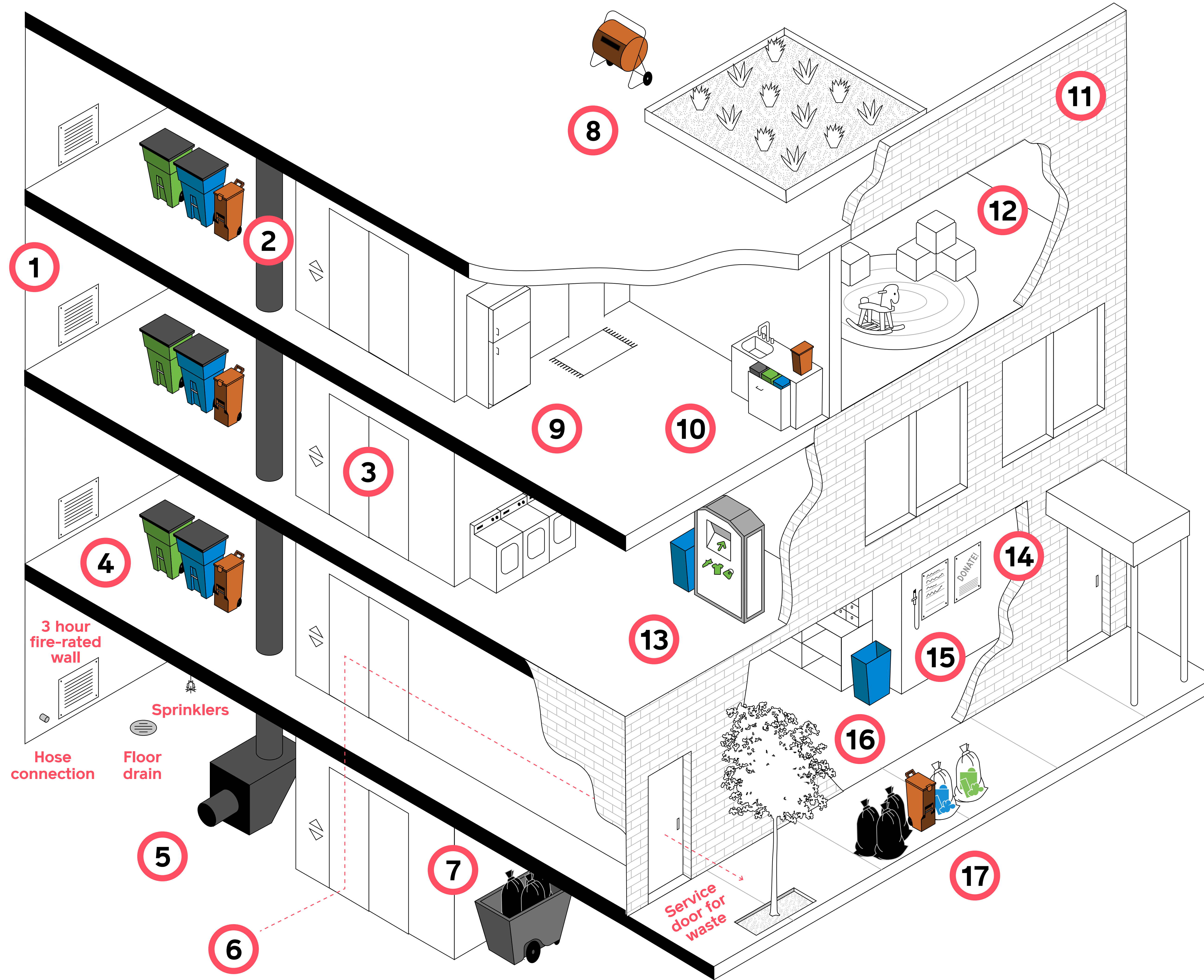

9. Shallow refrigerators and shelves to reduce “lost food,” or smart refrigerators. 2.17
10. Pull-out cabinet with bins (all waste streams) and counterop organics bin. 2.08
11. Consider impacts of building materials selection and construction process. Optimize material usage, consider end of life. 2.27–2.35
12. Consider amenities that reduce material consumption (e.g., children’s play areas with toys, shared goods library, cleaning service with vacuums). 2.15
13. Provide textile recycling and plastics recycling in laundry room. 2.13
14. Consider possibilities for reuse such as online bulletin boards and donation refrigerators. 2.18
15. Provide feedback on waste generation to residents and staff to change behavior. Consider how to incorporate SAYT back to resident. 2.11
16. Provide paper recycling in mail room and cardboard collection in parcel room. 2.13
17. Provide set out area, coordinate with street, trees, furniture, curb cuts and entrance. See NYC Rules for setout. 2.04

Commercial Building Context

An efficient route and enough space for waste storage are often missing from commercial buildings.



Commercial Waste Stream

In 1916, the New York City Sanitation Commissioner decided that to reduce the department's costs, the city would no longer provide collection services to commercial buildings. Forty years later, the city passed a law closing the loophole that had permitted municipal collection service for stores and other businesses located on the first floor or elsewhere in residential buildings. Since then, all commercial establishments have been required to hire licensed private carters, while the city has continued to provide municipal collection services for residential, nonprofit and institutional entities. According to the Department of Sanitation's 2012 "Commercial Solid Waste Study and Analysis," New York City's commercial waste sector recycles 24% (not including organics), compared to a national average of 34.5%. Reports filed with the New York State Department of Environmental Conservation by transfer stations and recycling facilities suggest that rates for major portions of the commercial waste stream may only be between 9%–13%.⁷

OneNYC set a goal of reducing commercial waste disposal to landfill or incineration by 90% by 2030. To reach the goal, DSNY is developing policies for three complementary approaches:

- Increasing data-reporting requirements to understand the current waste streams and diversion rates
- Reducing food waste generation through commercial organics rules that require food-scrap diversion and encourage donation first, and by raising awareness through mayoral food waste reduction challenges and food waste fairs

- Increasing capture rates for all diverted streams by aligning commercial and residential rules

This section describes specific initiatives related to these approaches. These initiatives should be considered when designing a building's waste-management layout.

Commercial Waste Composition

The objective of DSNY Sanitation's 2012 study and analysis was to determine both the quantity of commercial waste by stream and the amount of commercial waste being recycled at the time. The city also set out to evaluate opportunities for organic waste reduction and diversion. Because of the limited availability of data from transfer stations, commercial waste haulers and the businesses themselves, the city was only able to develop broad estimates on commercial waste composition. For the study, generation data was estimated using a per-employee model by business type. Additional information on generator and carter behavior, gathered by visually tracking curbside setout for representative street segments, didn't include waste from containers in loading areas or construction and demolition waste. The findings for waste composition within the study show that 89% of the city's estimated 3 million tons of commercial waste per year is suitable for recycling or organics diversion. Only 26% of that waste is currently diverted from disposal, meaning that just 29% of these recyclable or compostable materials are captured.

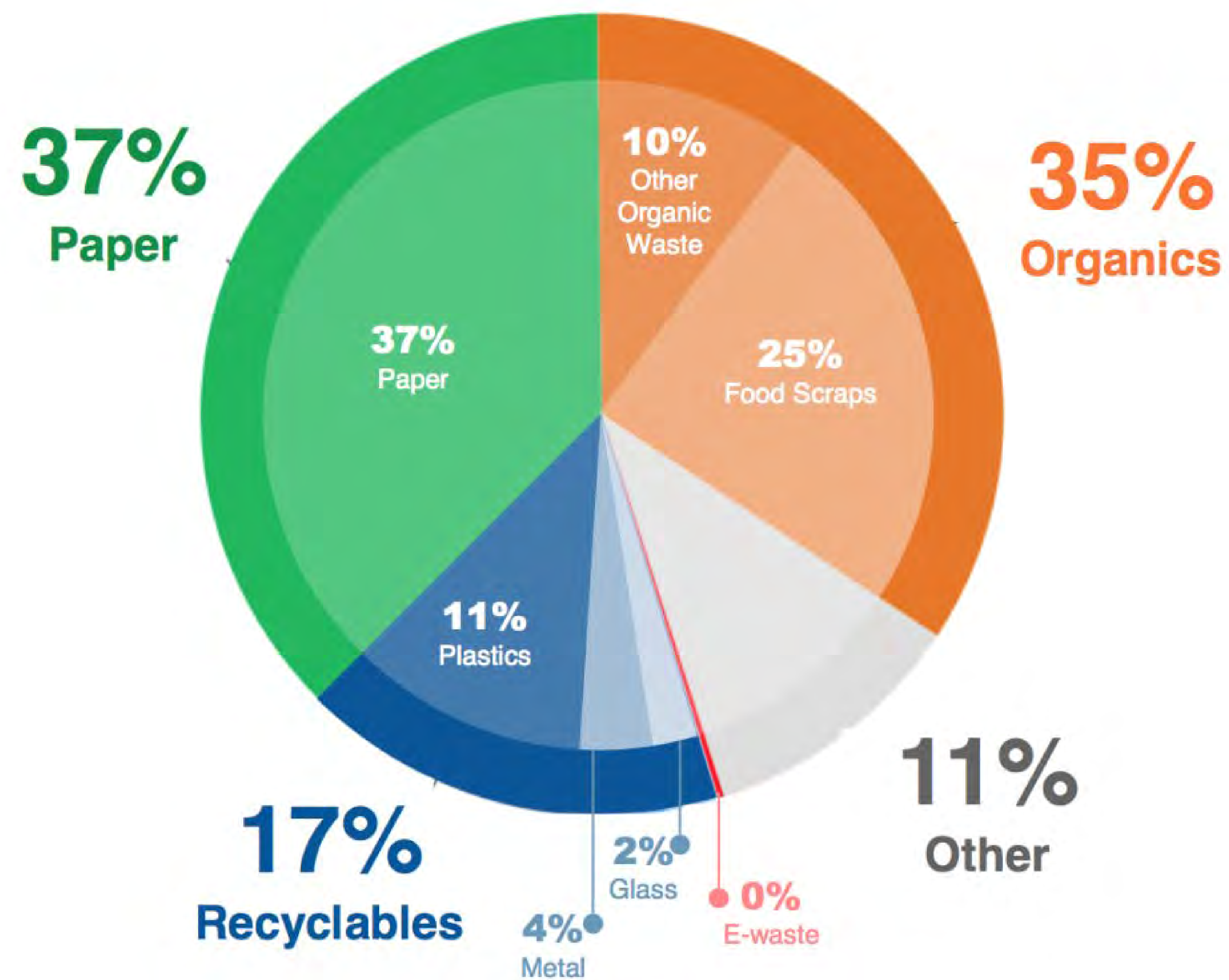

Commercial waste stream per 2012 data.

Accountability for diverting commercial waste from landfills or waste-to-energy facilities is complicated by the number of entities responsible for specific aspects of sorting, staging, setout and collection. Tenants (waste generators), building managers, cleaning companies, waste brokers and waste haulers all play a role in the process. Waste-hauling contracts are typically based on a flat monthly fee, often estimated from square footage and building uses. Because of this, recycling

and waste reduction do not always save costs, leaving businesses with little incentive to reduce waste. One reason is that there are currently limited mechanisms for tracking waste and recycling streams on a daily basis. The status quo offers significant opportunities for improvement.

Moving Toward Commercial-Waste Collection Zones

An analysis of private-carting operations conducted by DSNY and the Business Integrity Commission (BIC) found that collection-truck trips and consequent air-quality issues could be substantially reduced through a zoned collection, in which a single carting company would serve all businesses within the zone. A DSNY consultant is now developing the design for such a system. Through this system, DSNY hopes to be able to leverage collection efficiencies and improved diversion rates.

Encourage Periodic Waste Audits for Large Commercial Buildings

Requirements for energy auditing and energy-efficiency retrofits for large commercial buildings have led to significant energy savings. Metering waste is not as easy, but knowing the types of materials discarded and their volumes is the first step toward reducing waste.

Food Waste Reduction

To assist businesses in reducing food waste and diverting food discards from disposal to processing for beneficial use, DSNY is organizing annual food waste fairs through its Foundation for New York's Strongest. The fairs offer displays of equipment for managing organics and presentations about options for managing discarded food.

The first fair, held in August 2017, drew more than 1,000 attendees.



Far left: Foundation for New York's Strongest first annual Food Waste Fair, 2017

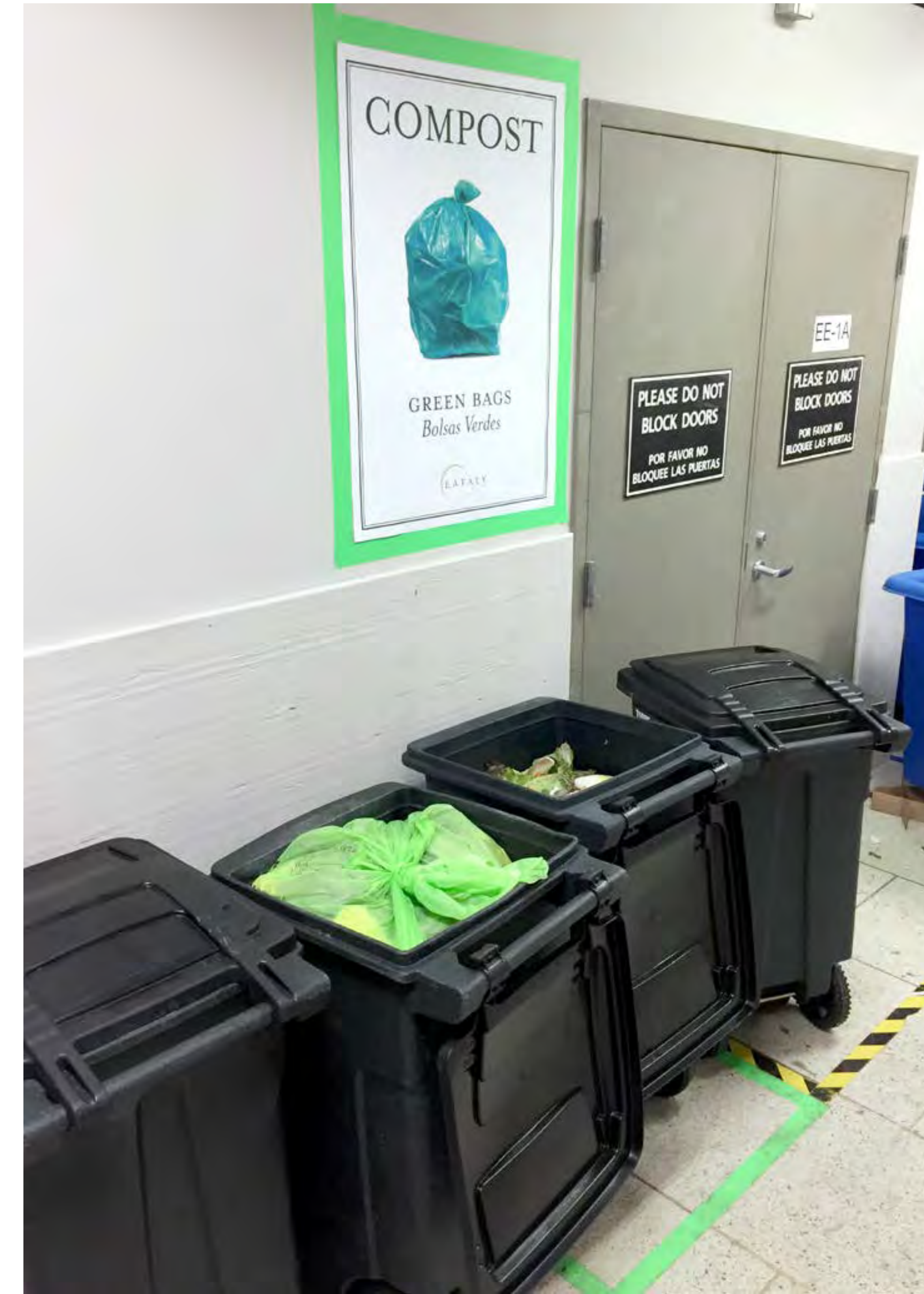

Left: Food waste storage area (in commercial buildings the color green is used for compost in accordance with international standards)

Organics Separation for Food-Service Establishments

Almost a third of the city's discard stream consists of organic materials such as food scraps, food-soiled paper and yard waste. The city is taking a phased approach to requiring food-service establishments to sort these materials from other discards designated for disposal so they can be collected separately and processed for beneficial use.

Aligning Commercial and Residential Recycling Categories

To reduce confusion and contamination and to increase the diversion of recyclables and organics, DSNY has aligned commercial recycling rules with residential ones. New Yorkers now must recycle the same materials at the office and out on the town that they recycle at home. The agency has also started a program to enforce commercial source-separation regulations.

Rules and Standards

Given NYC’s historic lack of regulations requiring source separation for businesses, there has been little provision to date for waste-management operations in commercial buildings. DSNY’s new commercial recycling and organics-separation rules will spur better planning and implementation for these functions. For sources, see [Building Rules & Standards](#) in Appendix.

DSNY Rules

Local Law 87 of 1992 made recycling mandatory for material collected by private carters. DSNY enforces its regulations under this law, which designates the materials that commercial waste generators must recycle and specifies the requirements for source separation prior to collection.

New recycling rules for businesses came into effect on August 1, 2016, with enforcement beginning on August 1, 2017. They include the following:

- There must be separate bins for refuse and recycling (which can be single-stream: metal, glass, plastic and paper combined), and all bins must be labeled.
- Wherever recyclables and refuse are discarded (whether in maintenance, waste-storage, staff or public spaces), there must be instructional signage indicating where specific categories of designated materials should be placed.

- Clear bags must be used for setting out recyclables: metal, glass, plastic, beverage cartons, paper and cardboard.
- Recyclables and refuse cannot be loaded into the same truck compartment for post-collection separation.
- Businesses generating significant proportions of textiles or yard waste (more than 10 percent of either) must sort these materials for separate collection.

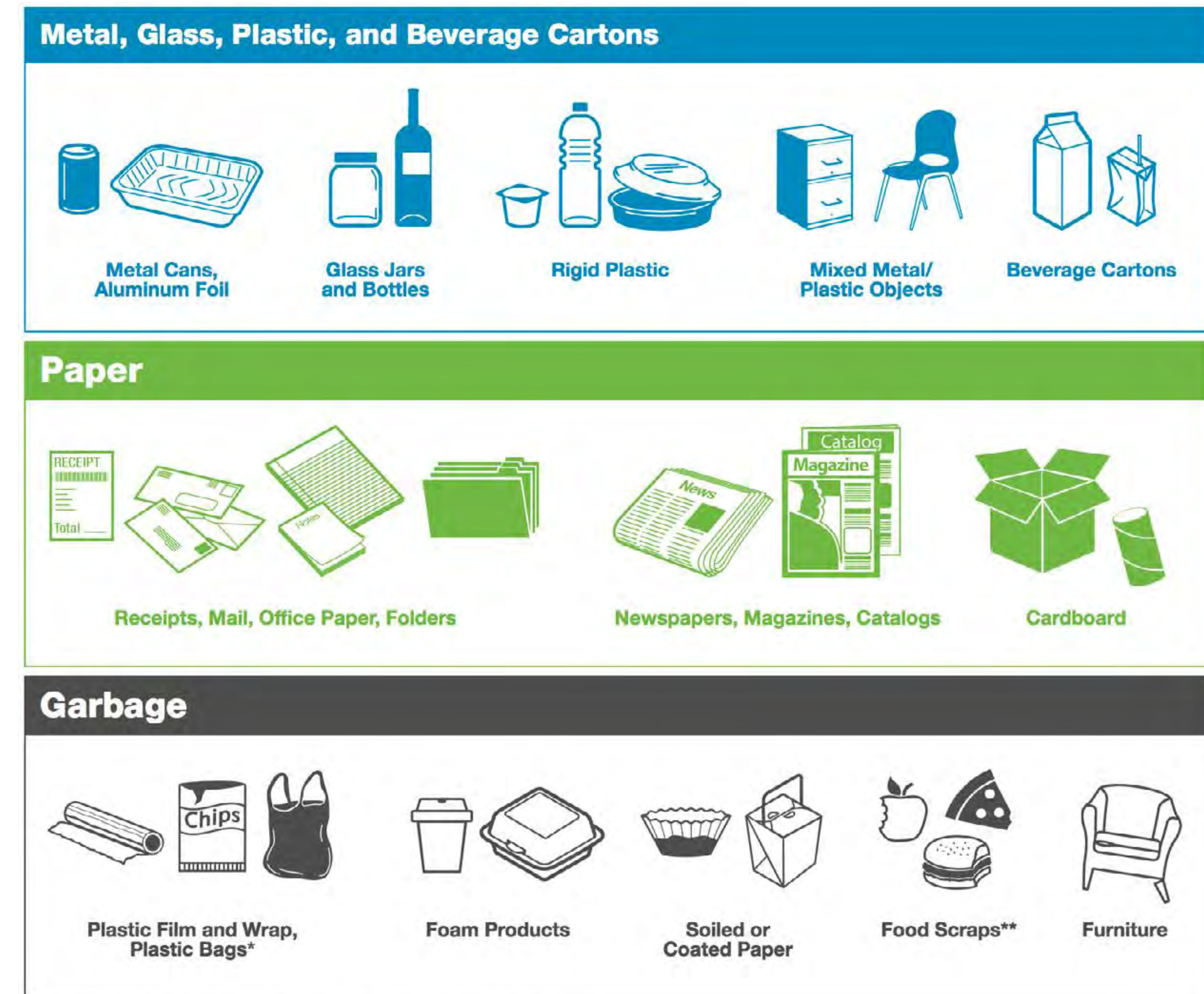

*Unless your business is covered by NYS Plastic Bag and Film Wrap law

**Unless your business is covered by Commercial Organics law

DSNY Commercial Recycling Rules

Local Law 146 of 2013 requires DSNY to perform an annual evaluation of regional organics-processing capacity to determine whether sufficient such capacity exists to accommodate a mandate that designated categories of food waste-generating businesses source-separate their organic discards. Since July 19, 2016, these categories of large food waste producers have been required to source-separate organic discards:

- All food-service establishments in hotels with 150 or more rooms
- All food-service vendors in arenas and stadiums with a seating capacity of at least 15,000 people
- Food manufacturers with a floor area of at least 25,000 square feet
- Food wholesalers with a floor area of at least 20,000 square feet

Designated businesses have the option to arrange for collection by a private carter, transport their organic discards themselves or process the material on-site. Permitted processing methods include composting and aerobic or anaerobic digestion (equipment must be registered with DSNY). A food waste grinder is not permitted.

On July 17, 2017, DSNY Commissioner Garcia announced plans to add the following tier of businesses to the source-separation requirement:

- Food-service establishments, such as restaurants, larger than 7,000 sq ft
- Chain food-service establishments with 50 or more locations in New York City
- Retail food stores, including grocery and big-box stores, larger than 10,000 sq ft

Building Code Requirements

The current building code includes no requirements for waste management in commercial buildings. As a result, most builders do not provide sufficient space for waste management. See [Chapter 4](#) on policy for suggested code language to address this omission.

Zoning Resolution Requirements (ZR)

The Zoning Resolution allows a deduction from floor area for provision of container compactors in large buildings in the Manhattan Core:

- ZR 13-32 allows exemption of up to 300 sq ft for dumpster storage adjacent to loading dock in buildings over 100,000 sq ft (minimum dimensions 12' x 25')

It also has some requirements for refuse-storage provisions:

- ZR 32-435 requires that plans submitted to DOB developments in high-density commercial districts show a central refuse area on the ground floor.
- ZR 37-94 requires a screened trash-storage area more than 50 feet from the street line be shown in the site plan for parking lots over 6,000 sq ft in commercial zones.

The ZR also specifies some places where trash storage is not allowed, such as enclosed sidewalk cafés and some plazas or arcades, or where screening is required.

TRUE (Total Resource Use and Efficiency) Rating

TRUE is a zero waste certification program for facilities.

The program is administered by Green Building Certification Inc. (GBCI), the certification provider for the LEED rating system of the U.S. Green Building Council (USGBC). TRUE Zero Waste Certification, given for 90% diversion of materials from landfill or incineration, is aligned with the LEED credit requirements for Buildings Operations and Maintenance (LEED O+M). See the [Building Standards & Certification](#) for more details.

LEED v4 Credits

LEED offers credits for materials and waste management, which include prerequisites for Storage and Collection of Recyclables, and Construction and Demolition Waste Management Planning. See the [LEED v4 Waste Management Credits](#) for more details.

Commercial Building Typologies

New York City has many types of commercial buildings with a wide range of uses. That means there is a greater range of commercial waste-management issues to be addressed than there is with the city's residential collections. In New York's larger buildings, construction and demolition debris pile up almost continuously because renovation projects occur on a regular basis. See [Construction & Demolition Waste Context](#).

Although commercial building stock varies physically in many ways and may include a combination of commercial, residential and institutional square footage, the management of commercial waste within buildings can be broadly categorized by four typologies. The method of collecting the waste is categorized independently as truck collection typologies. (See [Truck Collection Typologies](#).)

Each Commercial Typology is described separately and assessed in terms of:

- **Space required:** Building owners find space efficiency is desirable, especially on floors above grade.
- **Labor required:** Moving waste adds costs for a building owner.
- **Convenience to staff:** If systems are convenient and safe, staff are more likely to follow them.
- **Cost and maintenance:** Some typologies require equipment that adds capital costs and requires additional maintenance.

These four concerns are interrelated—and additional convenience to the building tenants in multi-tenant buildings will generally result in increased labor costs for the building operator. Similarly, equipment may reduce labor or hauling costs but increase capital costs and maintenance requirements.

Additional considerations relate to the best practice strategies in chapter 3, and the typologies are assessed in terms of how easily they can accommodate them:

- **Volume reduction:** Compaction leads to a reduction in volumes and area required for storage and setout of waste.
- **Diversion strategies:** Ease of incorporating diversion strategies include clear visual cues and equal convenience disposal, or the ease of adding organics collection with co-located bins.
- **Waste metering:** Design that can incorporate tracking or metering of waste for financial incentives and transparent pricing by stream

For a new building, the choice of typology depends on its size and usage, along with the factors discussed above. Suitable for small single-tenant buildings, typology 1 should have some interior or exterior storage space within the lot. Typology 3 or 4 is recommended for multi-tenant buildings, as typology 2 transfers responsibility for storage to tenants, making it much more difficult to develop a consistent building-wide system. Typology 3 is suitable when waste quantities are below that which would require a compactor to be emptied weekly (see [Waste Calculator](#)); Typology 4 should be used above this threshold.

COMMERCIAL TYPOLOGIES

1. Stairs or Ramp to Sidewalk
2. Elevator to Sidewalk
3. Elevator to Shared Storage
4. Service Elevator to Shared Compactor Containers (Loading Dock / Exterior)

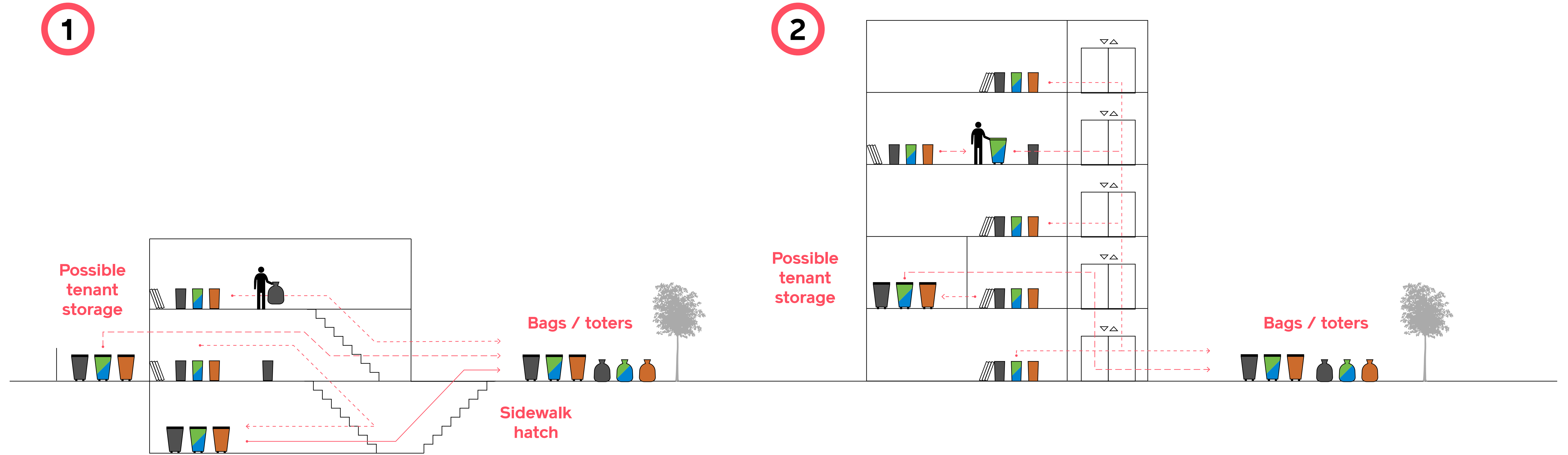

Transport:

By hand, bags	
Toter / Bin on dolly	
Tilt truck	

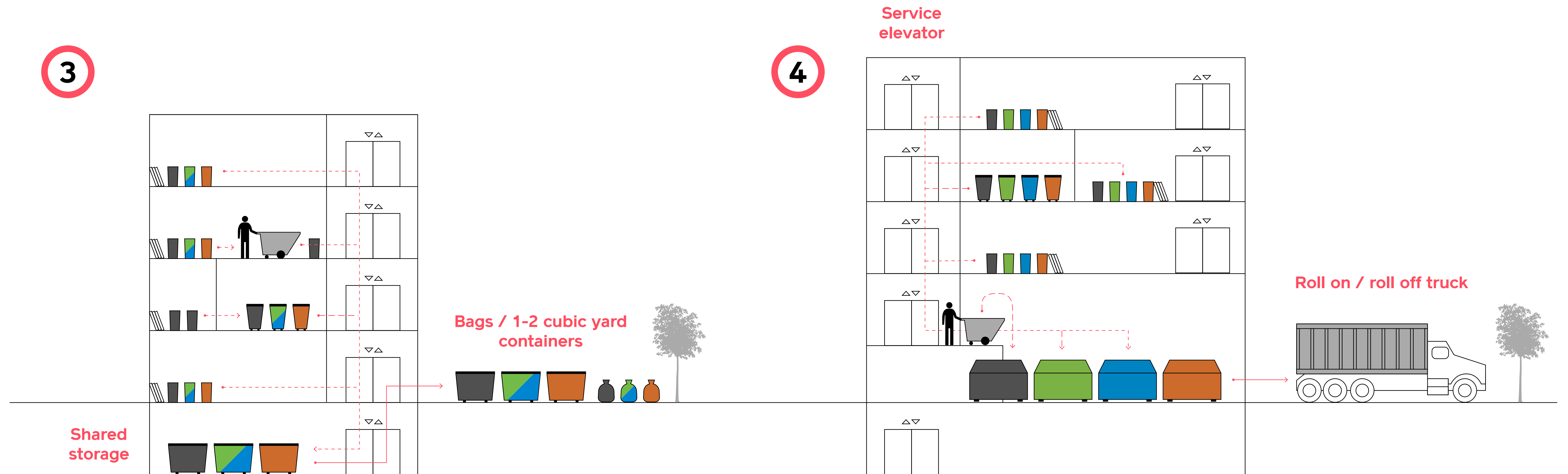

TYOLOGY 1: STAIRS OR RAMP TO SIDEWALK

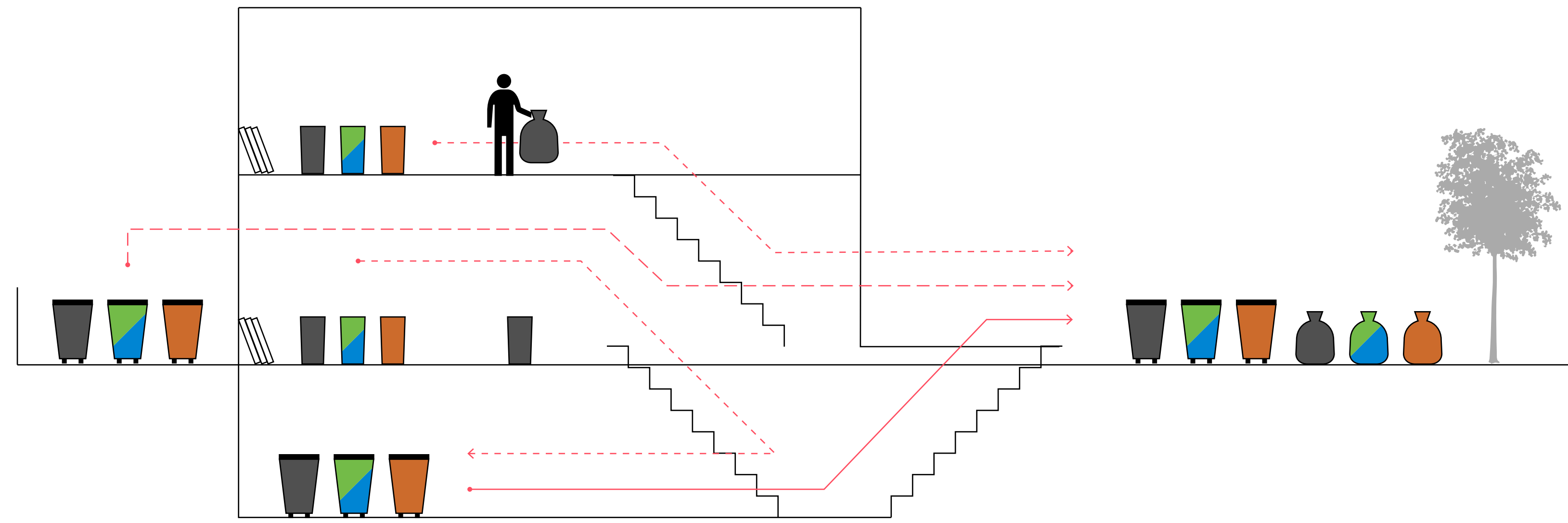

In the simplest scenario, businesses bring waste straight to the sidewalk, sometimes through a sidewalk hatch. There may be some storage in wheeled bins in a backyard or within the tenant space, but trash and recycling is generally set out in bags while organics are generally brought to the curb in two- or four-wheel bins.

This arrangement is typical for small restaurants and stores, which are generally in buildings with one or two stories of commercial space and sometimes a cellar below and residential apartments above.

Advantages

- Space efficient: Limited floor area given over to longer-term storage
- Low labor: Few or no setout containers brought back into the building after collection

Disadvantages

- Waste can block passageways or workflow (common in restaurants).
- Setout is generally in bags, which can attract pests and take up more public space than would setout in rigid containers.
- Collection needs to be more frequent.
- Less convenient: Waste must be stored within the business space until allowable setup times.
- Safety challenge: Some heavy waste has to be brought upstairs.

Alignment with best practice strategies

- Volume reduction: Normally no provision for compaction
- Diversion strategies are more difficult to implement in tight spaces that can't accommodate central, well-designed storage space for all streams. Bins may be accommodated in convenient "semi permanent" locations throughout a space, with visual cues such as color-coded and labeled bins.
- Waste metering/transparent pricing by stream is possible since the individual business/tenant contracts directly with a hauler.



Left to right:
Sidewalk hatch, shown open;
Waste stored in the cellar;
Stairs to cellar storage



Restaurant waste, cooking
oil and grease trap lined
up for collection

TPOLOGY 2: ELEVATOR TO SIDEWALK

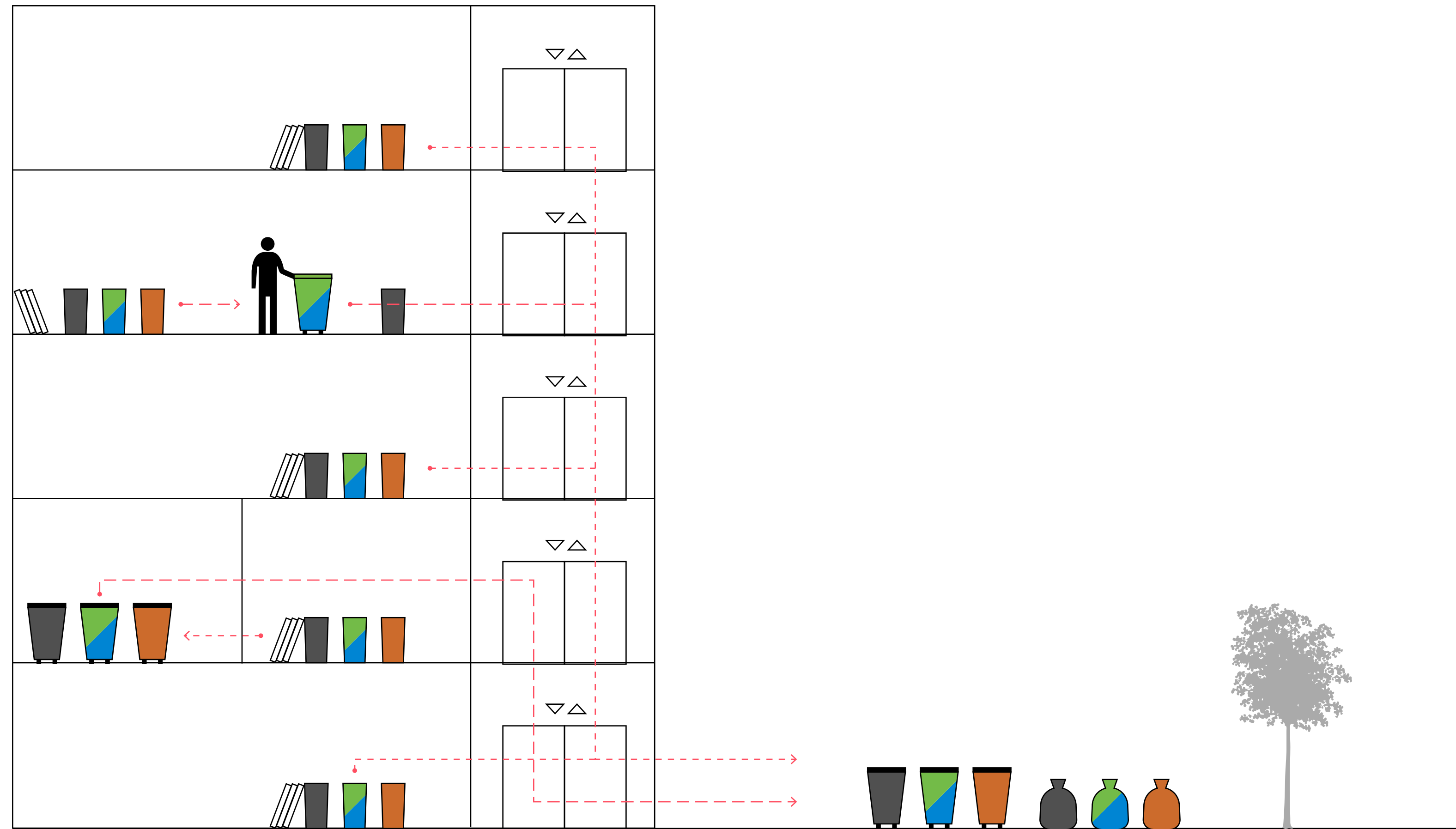

This typology is common in multi-tenant office buildings with elevators but no shared storage space. Before being taken to the street for setout, waste is stored in the tenant area, moved by the tenant or collected by building staff at a set time in bins on dollies or tilt trucks. Floors are serviced daily via the service or passenger elevator. Facilities or cleaning staff members generally use one bin to transport all streams, so standardized procedures need to be followed to appropriately separate types of materials at the curb to avoid contamination. Setout for refuse and recyclables is typically in bags, while organics are generally set out in wheeled bins.

Advantages

- Space efficient: Limited floor area is given over to longer-term storage.
- Low labor: Discards go directly to curb, and no or few setout containers are brought back into the building after collection.

Disadvantages

- Bag setout can attract pests and take up more public space than rigid containers do.
- Collection is more frequent.
- Inconvenience: Tenants must hold daily discards until a set time.

Alignment with Best Practice Strategies

- Volume reduction: Normally no provision for compaction
- Diversion strategies difficult to implement in limited space
- Waste metering/transparent pricing by stream is not common but is possible if maintenance staff can weigh trash collected from each tenant space using, for example, a tilt truck equipped with a scale and digital screen. There are also technical solutions used commonly in SAYT models, in which bags include RFID or QR-coded labels that can be scanned.



Clockwise from top left:
Recycling being transferred
from bin on dolly to tilt truck;
Freight elevator takes tenant
containers directly down to
street; Service entrance
to sidewalk freight elevator,
door opens onto street



TPOLOGY 3: ELEVATOR TO SHARED STORAGE

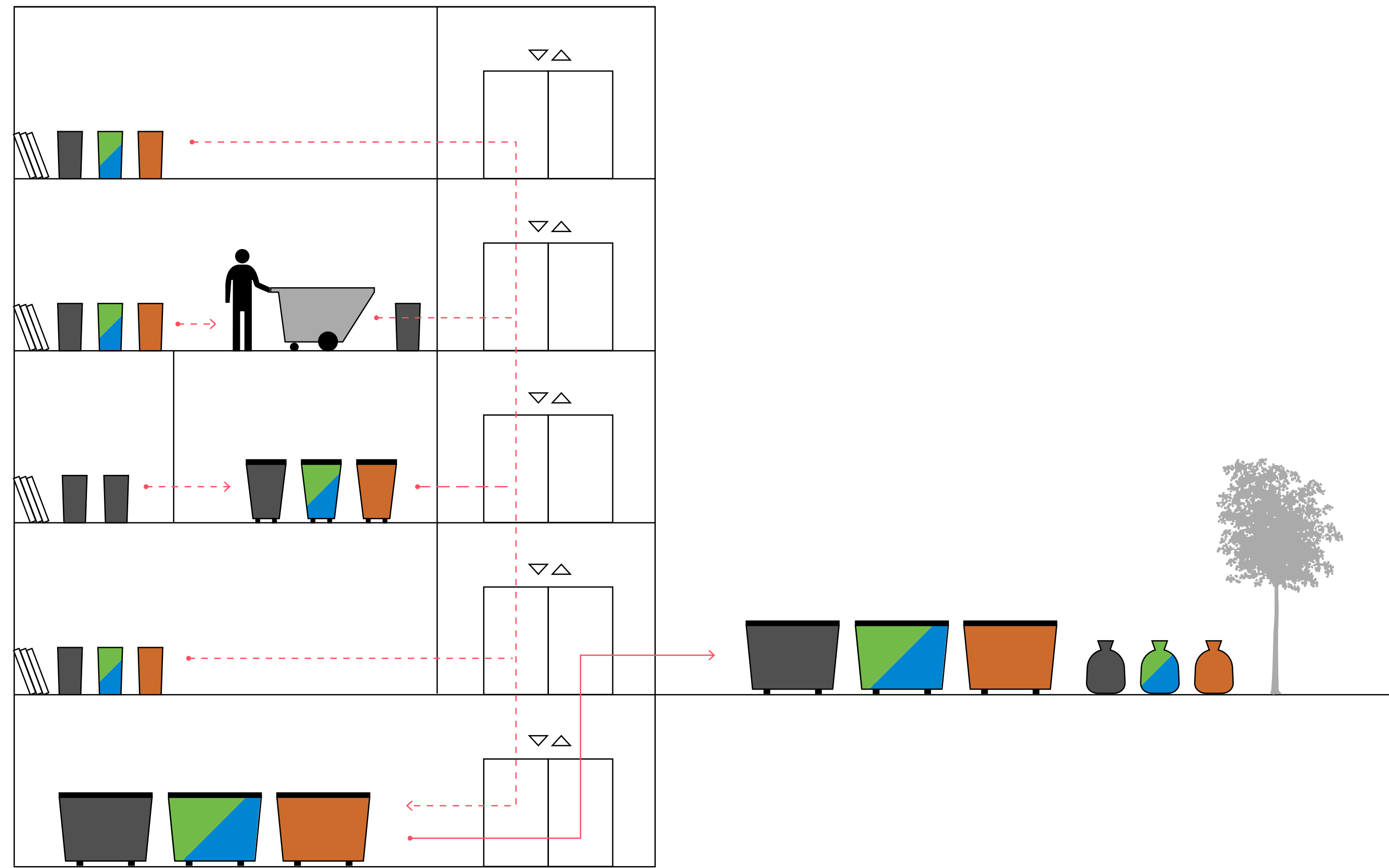

Some large multi-tenant buildings, such as those with office, hotel, university or retail uses, provide shared storage space. Waste is collected from tenant areas, placed in transport bins and taken by service or passenger elevator to the shared storage space where there may be balers. Waste can be brought to the storage space by building maintenance staff or tenants. Setout may be in 1–2 cu yd containers, wheeled bins or bags.

Advantages

- Convenience: The timing of waste collection from individual tenant spaces does not have to be coordinated with waste pickup from the building.
- Collection can be less frequent.

Disadvantages

- Space needs to be allocated for a storage area.
- More building labor is required to move waste from storage to curb.

Alignment with Best Practice Strategies

- Volume reduction: Compaction is possible (cardboard balers are common in this scenario).
- Diversion strategies are easy to implement with good signage and co-location of all waste streams in the storage space.
- Waste metering/transparent pricing by stream is not common but is possible, for example by charging tenants on a per-bag basis. This is labor intensive as staff time is required for tracking bags. A scale solution for tracking and recording waste can be built into the storage room. There are also technical solutions used in SAYT models where bags must include RFID or QR coded labels that can be scanned.



Clockwise from top left:
Baled cardboard and 2 cu yd
container set out for collection;
Organic wheeled bins in cellar
storage area; Waste stored in tilt
trucks; 2 cu yd containers and
cardboard in cellar storage area

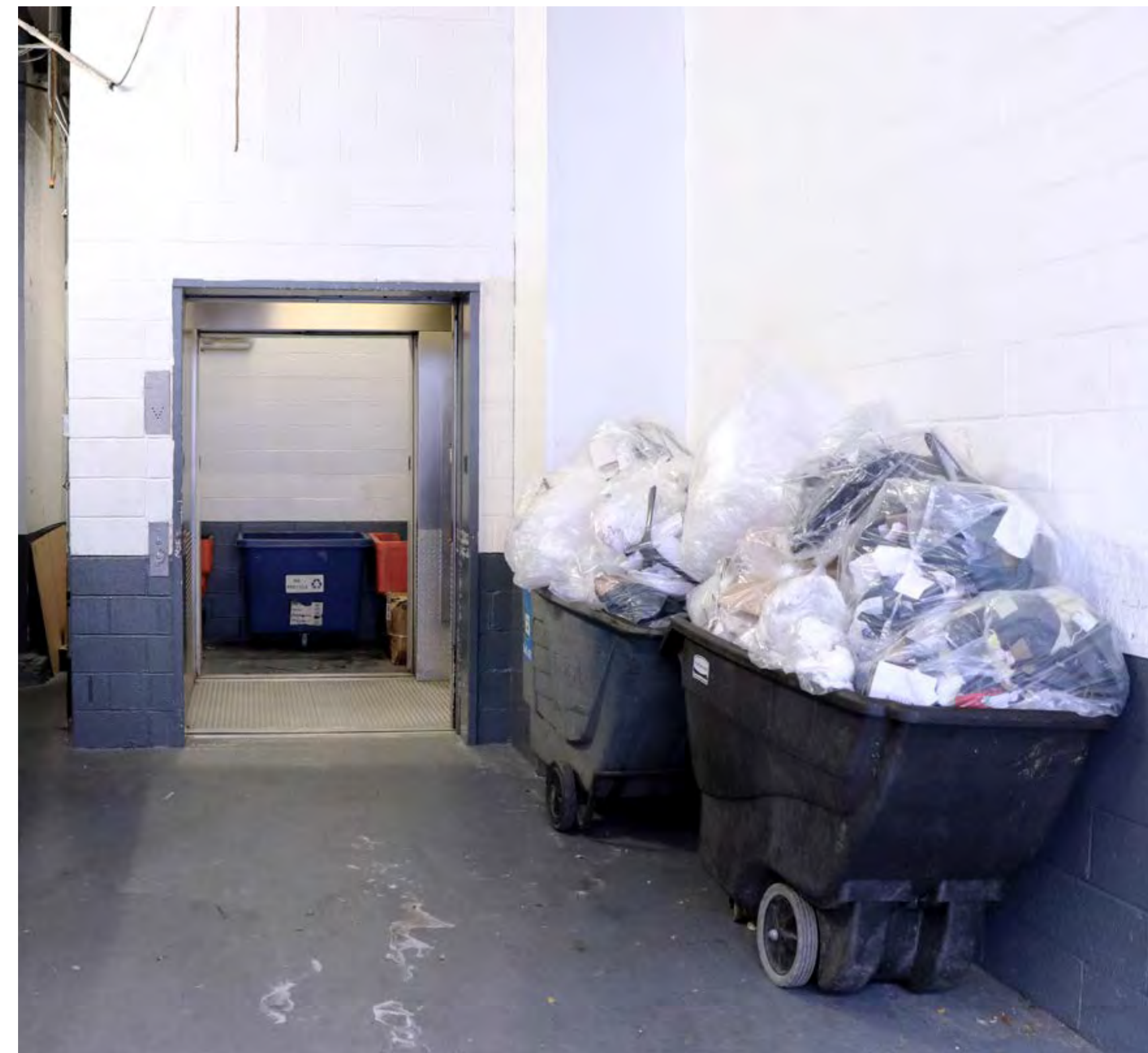

TPOLOGY 4: SERVICE ELEVATOR TO SHARED COMPACTOR CONTAINERS

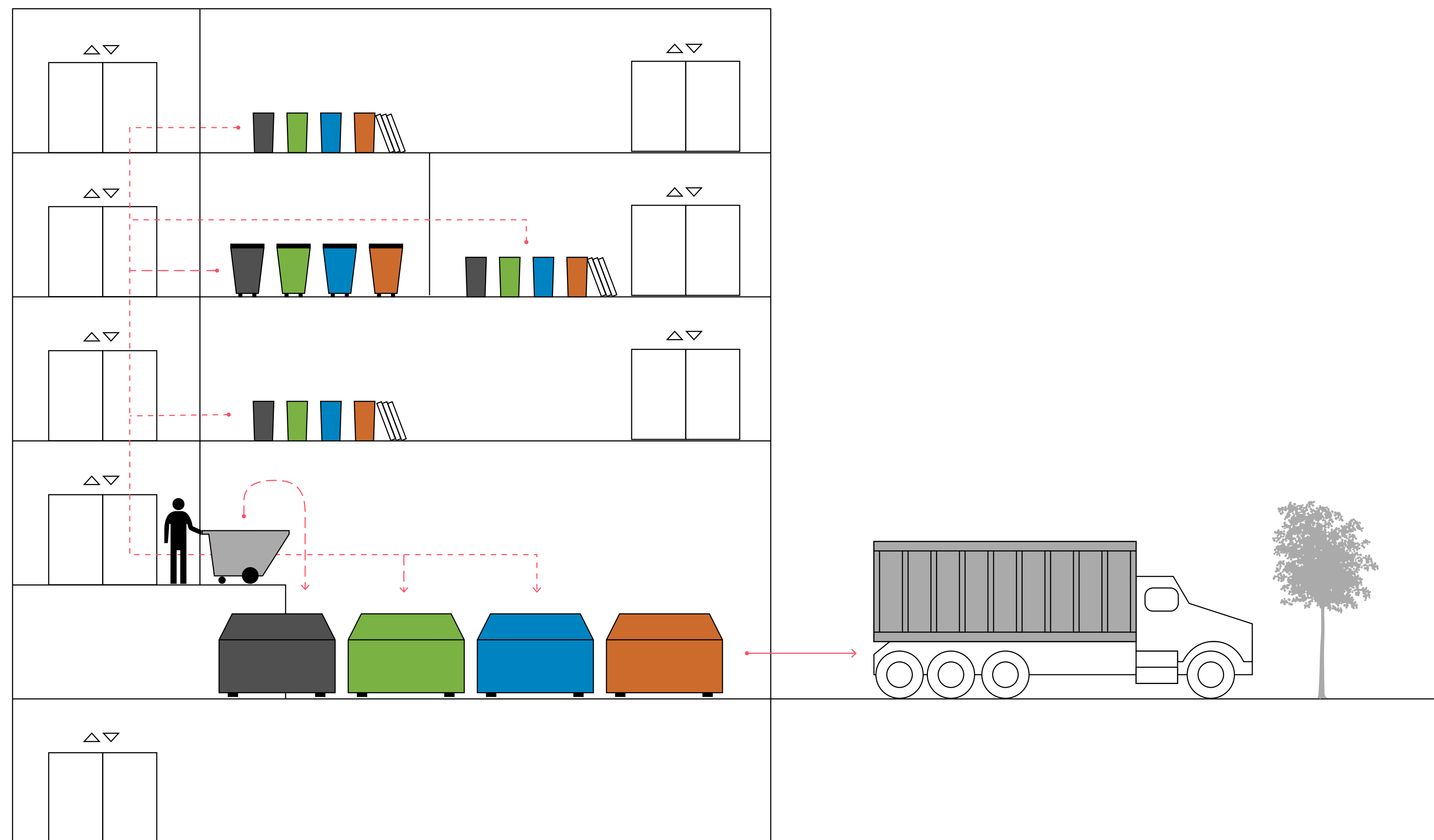

The ideal situation for large multi-tenant buildings is shared compactor-containers, which may be exterior or in an interior loading area. Waste is collected from tenant areas, placed in transport bins and taken by service elevator to the shared container compactors and other bins. Building or tenant maintenance staff can bring waste to the storage space. Automatic pressure detection can tell the hauler when the compactor is almost full and ready for collection; it is then removed by truck and returned empty. ID tags can be required for opening the compactor doors so that individual tenants can be charged for the number of times the compactor is used, or a scale can be included to charge by weight.

Advantages

- Collection is less frequent (with reduction, there can be a significant decrease).
- Convenience: The timing of waste collection from individual tenant spaces does not have to be coordinated with building waste pickup.
- Sidewalks remain free of waste.
- Self-contained compactors reduce odors and mess.

Disadvantages

- Space needs to be allocated in the loading area, which is in high demand in multi-tenant buildings.
- Waste management pickup needs to be coordinated with other building deliveries.
- Managing space and equipment increases labor.

Alignment with Best Practice Strategies

- Diversion strategies are easy to implement with good signage and co-location of all waste streams in the storage space.
- Volume reduction strategies are easier to implement, with compaction typical.
- Waste metering/transparent pricing by stream is possible but involves more technical solutions (such as compactors with key cards or mechanisms in the loading area for weighing waste).



Loading dock with shared compactors for multiple waste streams



Institutional Building Context

University of New Hampshire move in sale.
Instead of going in the trash, outgoing students' unwanted stuff helps new students furnish their dorm rooms.



Institutional Waste Stream and Rules

DSNY provides waste collection for city agencies and many large institutions, which must follow department rules. The rules require that a recycling coordinator be appointed to oversee a recycling program conforming to city regulations. Institutions may also have private carter pickup to supplement the service offered by DSNY, provided such private pickups conform to the recycling and other rules for private carter collection. DSNY does not separate waste data for institutions or city agencies; see the residential section for composition of all DSNY-collected waste.

Public Schools

For Zero Waste Schools, a OneNYC initiative, DSNY partnered with DOE to improve school waste management and identify best practices that could be expanded to school facilities citywide. DSNY also funds GrowNYC's Recycling Champions to work with DOE to educate students and staff about the importance of zero waste.

Most schools do not have dishwashing facilities. Until recently, lunch was served on polystyrene trays, resulting in a million unrecyclable trays per day. DOE worked with Natural Resources Defense Council (NRDC) and the Urban School Food Alliance to procure trays made of compostable paper instead, and DSNY has added equipment that allows these trays to be composted.

School facilities often house multiple schools within one building, along with after-school and independent programs, increasing the difficulty of developing standard procedures to manage waste.

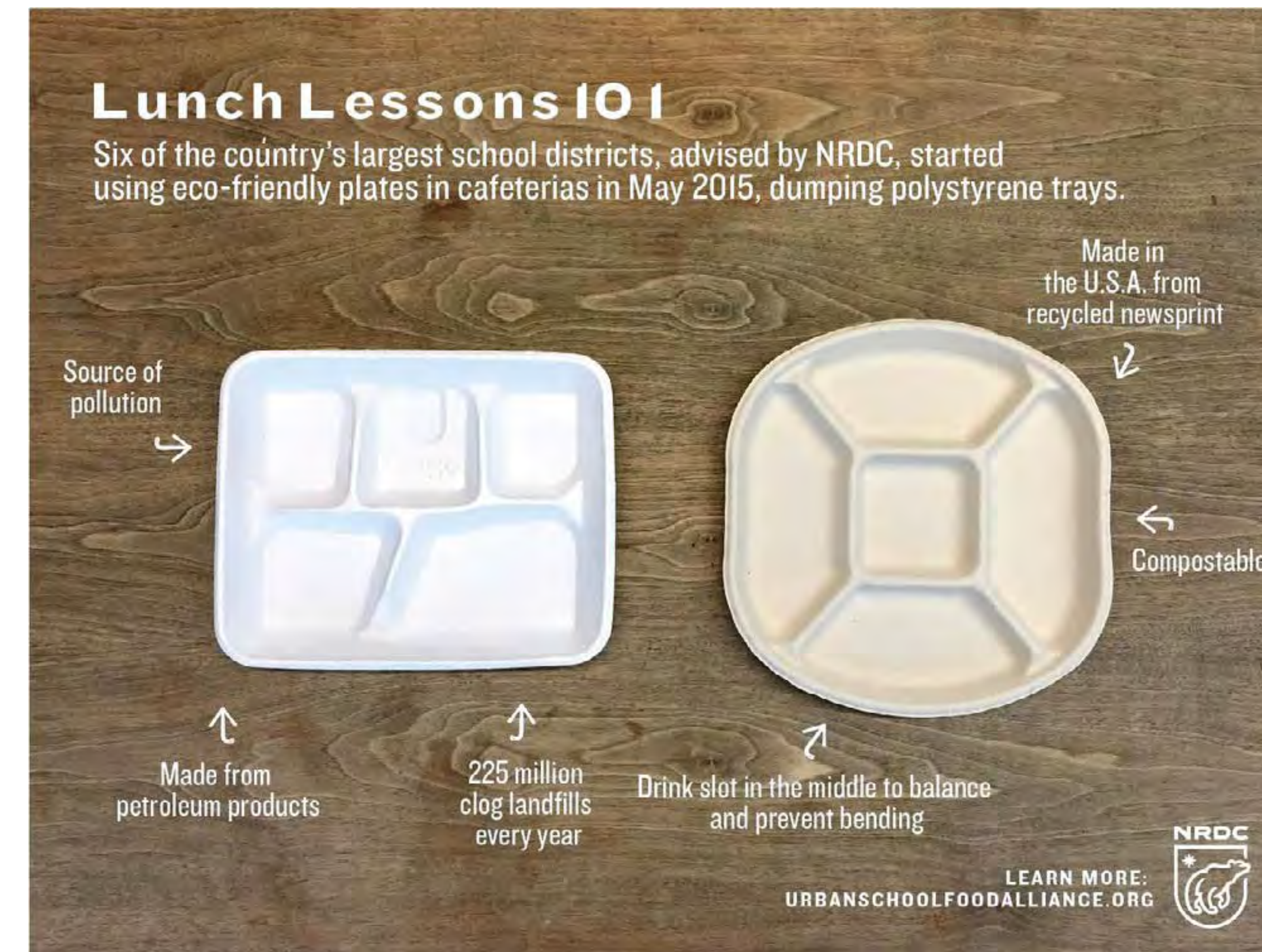

DOE serves lunch to 1 million children every day on compostable plates.



Typical school setout with organics bins

Schools in general grapple with a high volume of food waste and related disposable dishware, drinks containers and paper streams.

New York City Housing Authority (NYCHA)

Many NYCHA buildings did not have recycling bins or separate recycling pickups until recently. Many have small chutes in the corridors, with no room allocated per floor for recycling. See [Residential Typology 3](#), and how NYCHA, DSNY, GrowNYC, Green City Force and NYC Service worked to bring recycling to all NYCHA developments by December 2016. Exterior recycling bins are now on concrete pads, often midway between two or more buildings. NYCHA is working on a comprehensive recycling plan to incorporate food-scrap management and increase recycling in its buildings citywide.



NYCHA recycling station

Universities

Universities may have DSNY or private carter pickup; some have both. Universities typically have their own standards and policies for reducing the volume of discards and maximizing the degree of diversion from disposal. Large campuses have their own challenges in maintaining consistent standards of operation, but campus-scale operations also present many opportunities for sharing equipment and efficiently consolidating waste management.

Campuses generate high volumes of food-service-related waste, food, disposable dishware, drinks containers and bottles and cans, as well as paper. Some also have to manage significant volumes of regulated laboratory waste streams. And dorm-generated waste



DOE school waste station

includes a large amount of cardboard related to the high volume of package deliveries.

The especially high rate of residential turnover at universities is accompanied by a high volume of bulk items left annually on campus, with limited to no staging area. Many universities have programs to reduce this, such as a University Sustainability Office, University Sustainability Principles, peer-to-peer education, student groups and intercollegiate recycling competitions. Also, tools like Freecycle and bulk-item donation programs are placed on many NYC campuses. Students are often motivated to recycle and actively engage in the sharing economy.

Hospitals

Hospitals have unique waste-management issues, with high-volume streams of disposable waste generated through the need to maintain sanitary protection. They also have specific regulated medical waste streams, including “sharps” (needles and disposable blades) and biological and pharmaceutical wastes, which require strict handling. Food waste is a big issue in the hospital context, and policies to reduce kitchen and serving-tray waste—as well as to divert organic waste from disposal—can have a major impact.

Typologies and Best Practices

New York’s institutional buildings have many types of uses but correspond to commercial typologies for waste management or, in the case of university dormitories, residential typologies. Refer to the relevant typologies and best practice strategies.



University bulk reuse event organized for the University of New Hampshire by PLAN

Residential, Commercial & Institutional Best Practice Strategies

Reducing volumes 5 to 10 times saves labor in the building, space in waste storage rooms and on sidewalks, and may also reduce truck trips.



Architects often consider how to reduce waste during building construction, but they can also design to reduce ongoing waste generated during the life of their buildings, just as they consider reducing energy and water use. Designing for material flows will not only reduce waste sent to landfill but also improve convenience for residents, working conditions for staff, the quality of public space around the building and the successful operation of the collection and the processing infrastructure into which it feeds. Strategies fall into the following broad categories:

1. Planning for Materials Flow Through a Building

The flow of goods delivered to the building is mirrored by the flow of outbound discarded materials. Planning for these flows is key to efficient waste management. Plans should cover quantities, routes, equipment and staff procedures, storage space design and collection setout.

2. Making Waste Separation Easier

Good design can simplify the disposal of materials in separate containers and increase diversion rates. Design can also create a coherent system for users via consistent visuals and signage throughout the building and by incorporating waste data feedback. If trash disposal is more convenient than recycling (and organics) streams, separation will be a greater challenge.⁸

3. Reducing Material Consumption Through Programming Decisions

Lowering consumption reduces eventual waste generation. Therefore, any programming decisions to reduce the amount of items procured—for example, through sharing equipment and furniture in an office space;

or providing reusable rather than disposable dishware in a restaurant—should be encouraged.

4. Reducing the Volume of Waste

Equipment that reduces the volume of waste can reduce storage space, setout space and collection truck mileage. Organic waste pretreatment can significantly reduce the weight as well as the volume of organic waste. Equipment adds costs and operational considerations and is only recommended in certain situations. Using the [Waste Calculator](#) can help in determining when equipment should be considered.

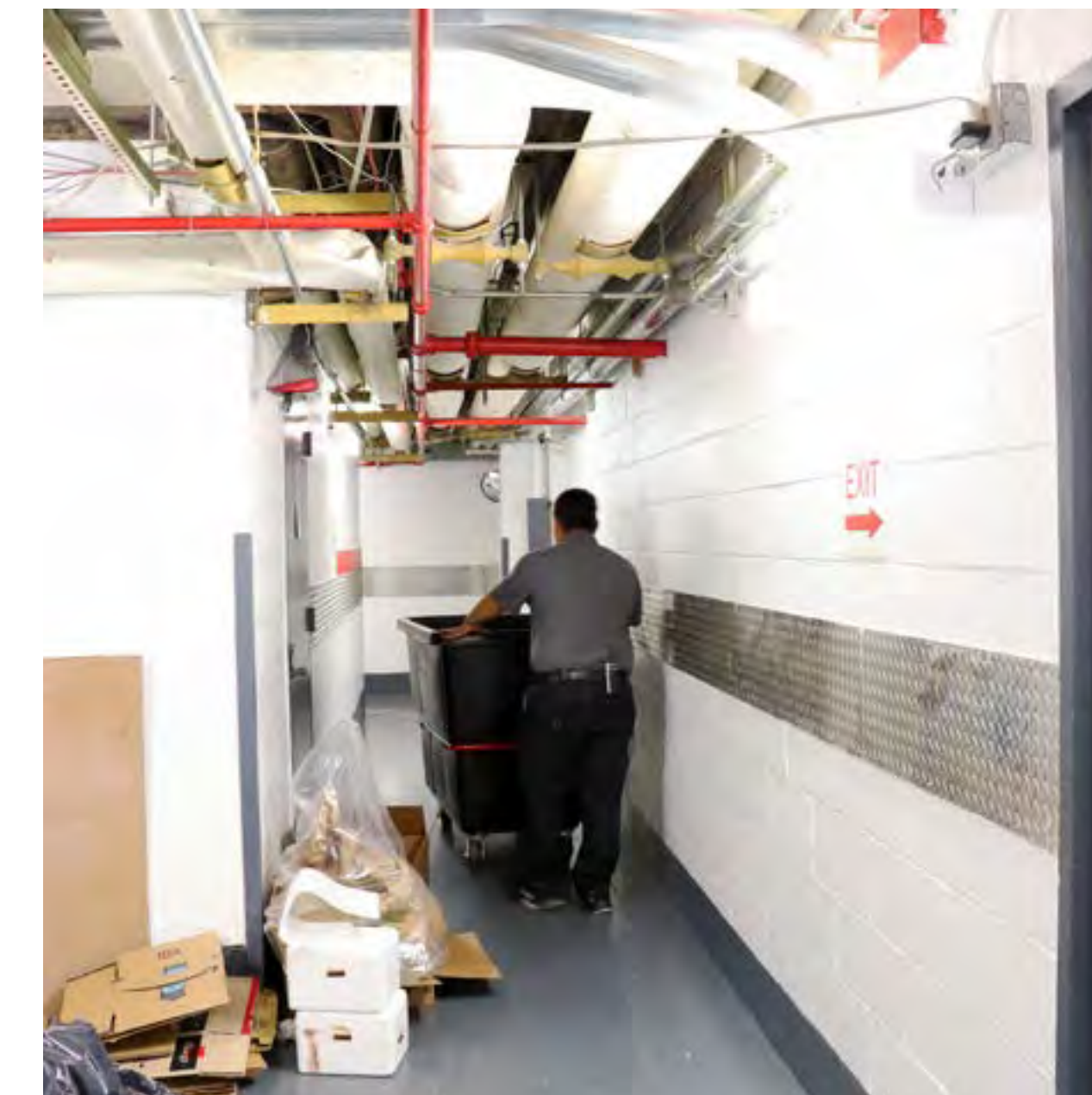

Moving waste materials through service corridor; Waste separation station



Reusable plates at buffet; Baled cardboard reduces setout space

Designing for zero waste is a collaborative process, and it needs to start at the beginning of a project. Considerations per phase include:

Pre-design Phases

- Include waste in sustainability planning: Hold integrative design workshops, set goals for waste reduction and diversion, organics separation and reusable dishware usage.
- Programming: Look for opportunities to share space and equipment.
- Use the waste calculator for an initial estimate of waste quantity.

Schematic Design

- Consider typology choices (residential, commercial and truck collection)
- Initial waste management plan: Plan for disposal, separation, storage, movement and collection of all waste streams. Coordinate with building management, engineers, and landscape architect.
- Consider using waste-metering methods.

Design Development and Construction Documents

- Design for any volume reduction equipment.
- Update waste management plan: Include any commercial or institutional tenants.
- Update waste goals: Look into opportunities for waste reduction, donation, packaging, and supplier takeback of packing containers
- Develop waste-metering methods.
- Develop waste/recycling stations and signage.

Handover and Occupancy

These may be developed by a building owner and management but should build on previous waste management plan.

- Final waste management plan including standard operating procedures and all bin types and locations.
- Develop awareness and education programs.
- Re-do waste calculations to reflect any waste reduction and diversion goals.
- Develop waste/recycling stations and signage (if not already extant).
- Consider volume reduction equipment (if not yet done).

For a new building, all the phases should be considered. For an existing building, the starting phase depends on the extent of renovation work. Recycling and better waste management can also be retrofitted into buildings with no ongoing renovation.

The [Best Practice Strategies Checklist](#) indicates applicability for commercial and residential buildings. For institutional buildings choose based on occupancy.

Planning for Waste as a Material Flow

Designing a building for those who serve the building, as well as those the building serves, makes the building better for everyone. Designers often fail to take into account the processes of maintenance staff

WASTE MANAGEMENT PLAN

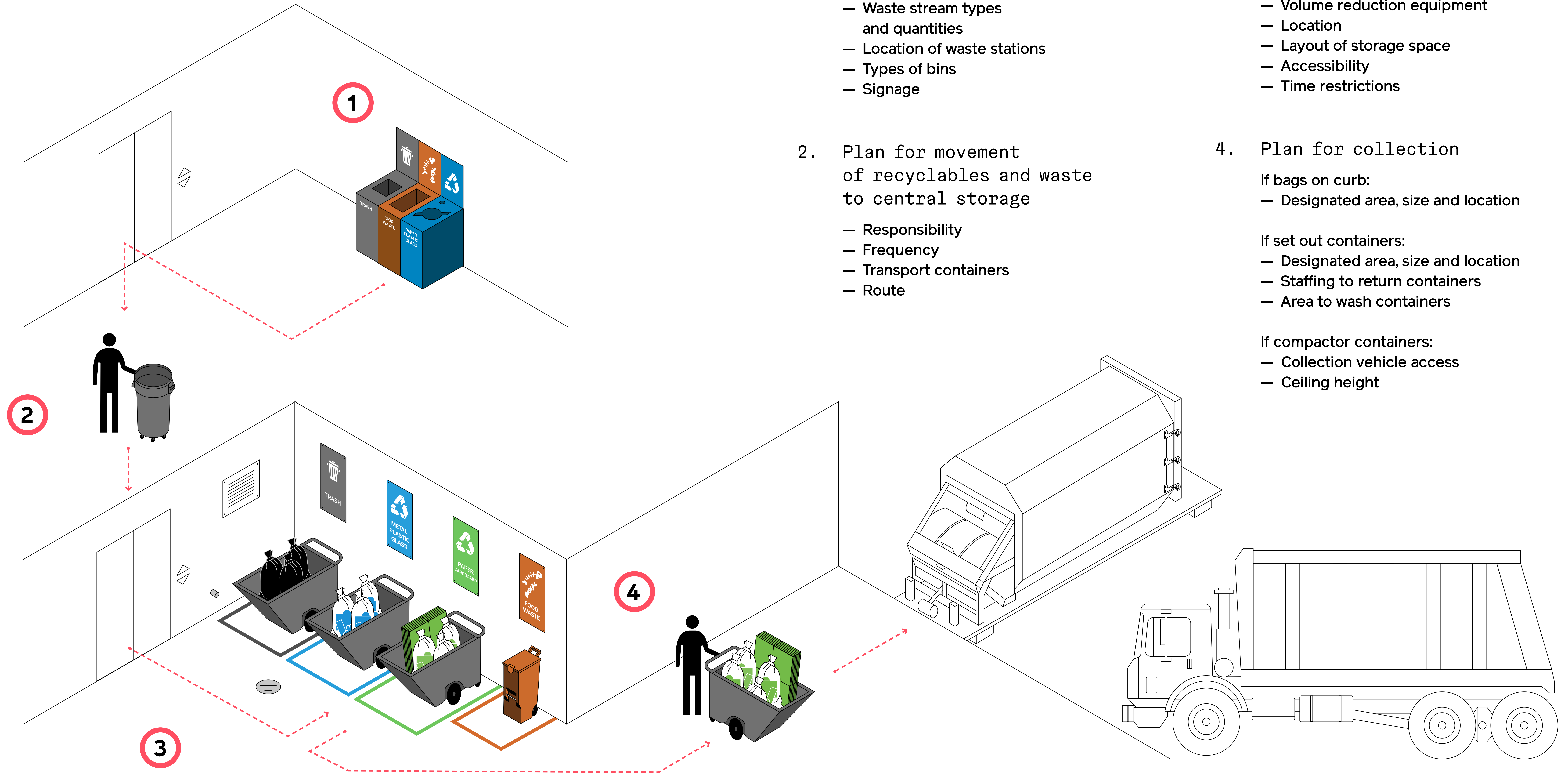

1. Plan for tenant disposal and separation

- Waste stream types and quantities
- Location of waste stations
- Types of bins
- Signage

2. Plan for movement of recyclables and waste to central storage

- Responsibility
- Frequency
- Transport containers
- Route

3. Plan for waste storage

- Calculate area required
- Volume reduction equipment
- Location
- Layout of storage space
- Accessibility
- Time restrictions

4. Plan for collection

If bags on curb:

- Designated area, size and location

If set out containers:

- Designated area, size and location
- Staffing to return containers
- Area to wash containers

If compactor containers:

- Collection vehicle access
- Ceiling height

and the flow of materials in a building. When these are accounted for, employee safety and satisfaction, hygiene and occupant satisfaction all improve. When they're not considered, points of friction are introduced to the system, frustratingly workers daily with ever increasing impact.

In visiting many buildings, we have seen great differences between them. Because an architect's scope of work doesn't generally allow him/her to find out how well a building performs for the maintenance staff, the architect remains unaware of problems so can't learn from them. And we've noticed that when building management values the creativity and ideas of every player, friction is reduced and solutions are found.

The depth a designer can reach in planning for waste varies depending on whether the building is existing and occupied or is planned without an idea of future occupant. Strategies below are comprehensive and should be considered as far as relevant.

2.01 DETERMINE WASTE STREAMS AND QUANTITIES

Planning for waste requires knowledge of the type and quantities of discarded materials. Planned space should be flexible because waste streams and recycling procedures often change over time.

Waste streams and quantities can be determined by:

- A waste audit for an existing building or from another location of the same business. Options can range from in-depth—weighing waste containers or bags—to a full “bin dig,” in which all waste is separated, categorized and weighed. In more-complex

commercial buildings, hiring a waste consultant to make accurate estimates is common practice.

- Average waste data for different use categories. In NYC, there are City Environmental Quality Review (CEQR) requirements to include estimated waste data in initial environmental assessments for large developments that could lead to 50 or more tons of discarded materials per week. To assist in calculating waste, the CEQR manual includes estimated pounds per resident, employee, student, hospital bed and inmate for different building uses.
- Waste Calculator: This uses local average waste data and includes recommendations for volume reduction equipment, storage containers and area.

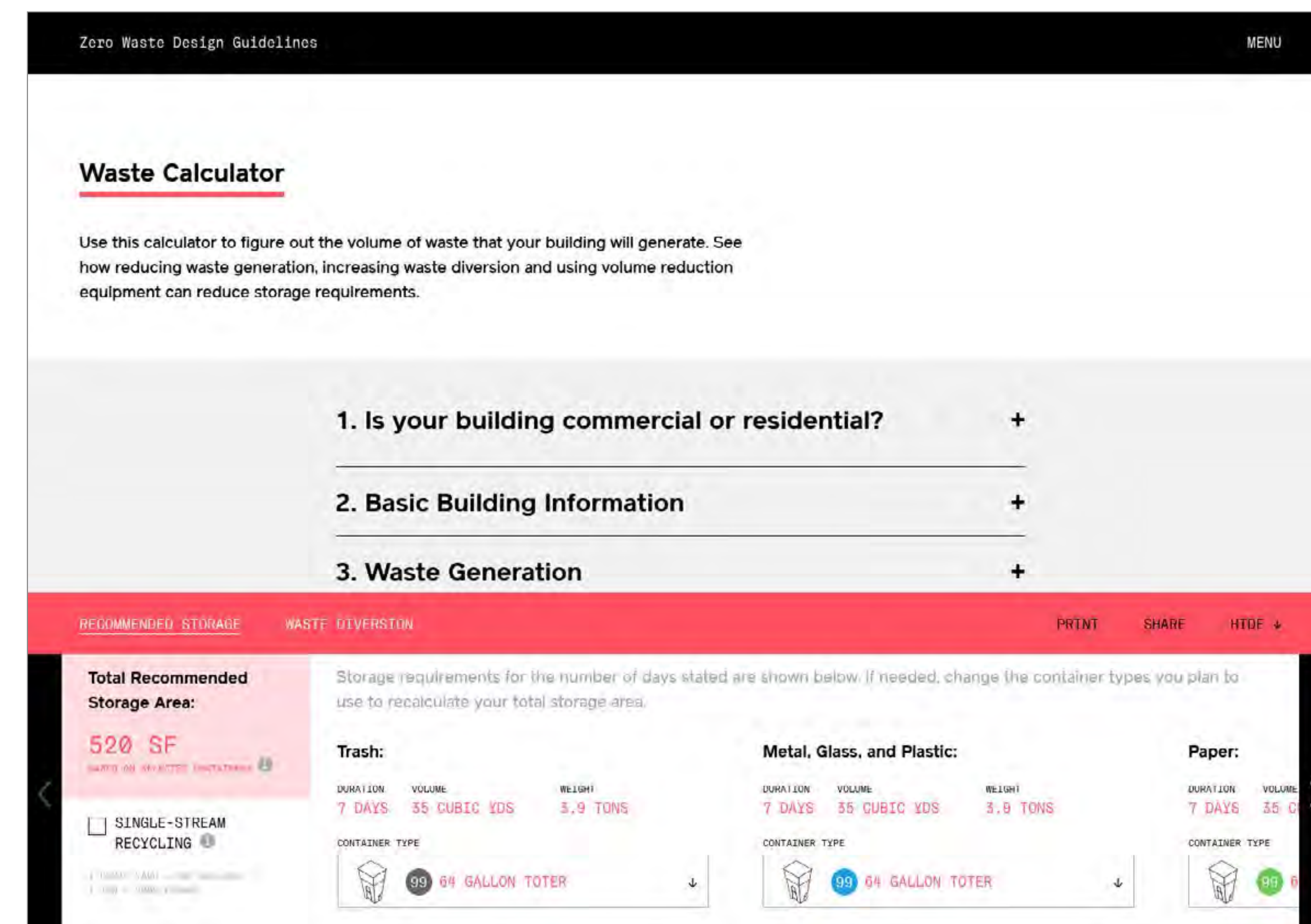

The Zero Waste Design Guidelines Waste Calculator

2.02 PLAN A ROUTE

Designing a route through a building for material discards requires consideration of transport methods, staffing and any restrictions in usage of elevators, service corridors or chutes or lifts. Strategies include:

- Minimize travel distances for staff.
- Minimize handling/transfer points as there is potential for contamination of streams at each handling.
- Provide for safe vertical transfer methods via elevator, lift, ramp or chutes. Stairs are common in older low-rise commercial buildings, but limit the weight of waste containers, and can lead to staff injuries. Service elevators take up additional area, but use of passenger elevators can inconvenience occupants. Material lifts (dumbwaiters) cost less, but staff do not enter, so need to coordinate loading and unloading. Though ramps consume space, they can be designed into exterior courts or yards, so service doors can come from cellar spaces.
- Consider transfer methods: Is an elevation change required, such as that at a loading dock that enables tilt trucks to tip waste into a 35 cu yd container? Otherwise, it may be necessary for staff to lift and throw heavy bags, or provide a mechanical means of lifting.
- Consider time restrictions for elevator usage, movement through common spaces, staff hours or collection hours and the like.

Consider containers for transport and storage

Waste is usually discarded and transported in containers. Different sizes and configurations suit different purposes. (See [Waste Bins in Buildings](#).) Consider:

- Whether provision and space needs to be given for washing containers
- Clearances and turning radii for containers
- Storage of transport containers
- Staff safety (weight of transport containers)

Consider chutes and sorters

Chutes, which rely on gravity to transport waste through a building, are more common in residential buildings. The [Chute Options](#) infographic shows the most common options and considerations.

When chutes connect to bags in wheeled bins, they have to be serviced much more frequently. If they can connect, through a compactor, to larger 1–2 cu yd containers, the connection can be tighter, improving hygiene and requiring less frequent servicing. (See [Avalon case study](#).) This is especially important for organics chutes. There are very few buildings that have organics in chutes. Issues include a requirement



A semicircular ramp is designed into the exterior court, allowing waste to be wheeled from the basement to the sidewalk

for more frequent washdown, and concerns about compostable bags breaking over a certain number of stories. Recycling chutes may empty into tilt trucks, then transfer the material to bags for setout.

Chutes often get blocked when residents insert bags of textiles or cardboard. Separating textile and cardboard collection can help in reducing the likelihood.



Top to bottom:
Multiple chutes
to wheeled bins;
Multiple chutes to
2 cu yd containers

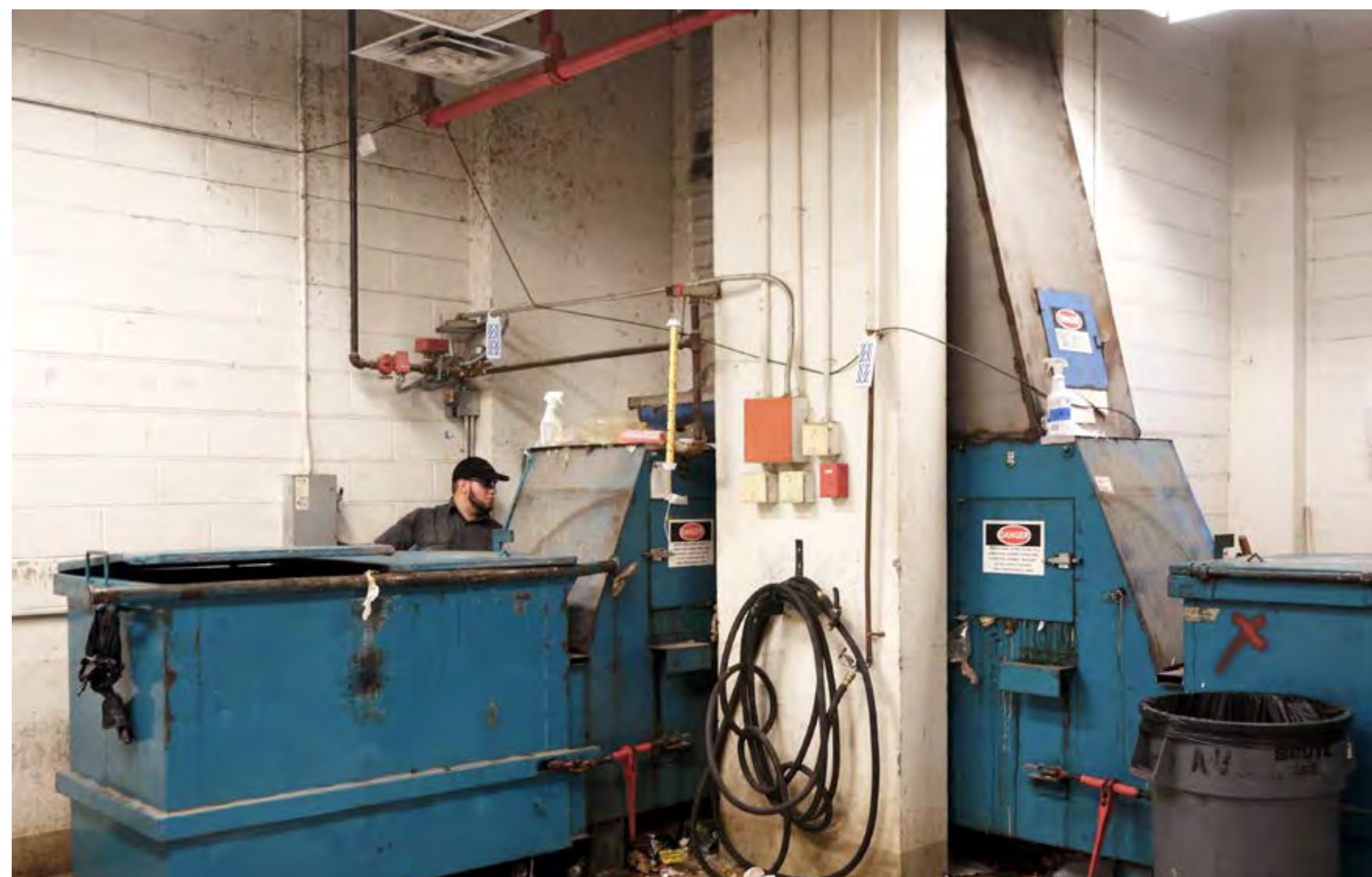

2.03 DESIGN STORAGE SPACE

Research shows that well-designed storage spaces increase diversion.⁹ Because many commercial buildings lack adequate storage for waste, it ends up monopolizing loading docks and corridors, pushing loading to the street and/or blocking egress. Consider:

- Storage area required and clearances for movement of containers
- Mechanical considerations: ventilation, temperature, lighting, water and drain for washing down containers
- Access to exterior
- Flood plain: With a cellar at risk of flooding, consider using larger containers as opposed to bags, or store waste at grade.



Loading dock filled with waste storage

WASTE BINS IN BUILDINGS

Stationary Container “Slim Jim”

Used at disposal locations within building

SIZE	TYPICAL DIMENSIONS			FOOTPRINT
	LENGTH	WIDTH	HEIGHT	
32 gallon	20"	11"	30"	1.5 SF

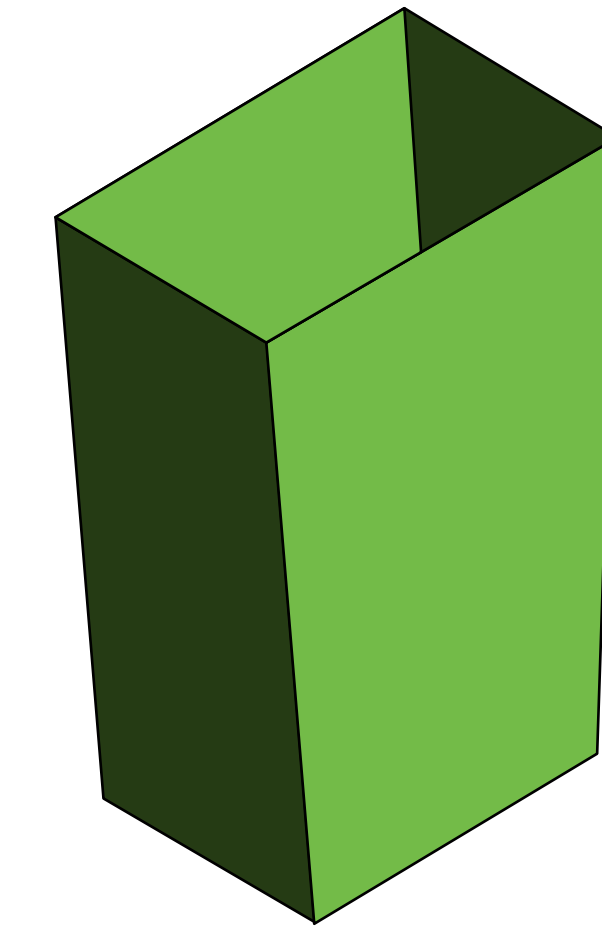

Wheeled Bins

Used for disposal locations within buildings, storage or setout

SIZE	TYPICAL DIMENSIONS			FOOTPRINT
	LENGTH	WIDTH	HEIGHT	
13 gallon	14"	12"	30"	1.2 SF
21 gallon	22"	18"	35"	2.8 SF
32 gallon	24"	19"	38"	3.4 SF
48 gallon	29"	24"	38"	4.8 SF
64 gallon	32"	24"	42"	5.3 SF
96 gallon	36"	30"	43"	7.5 SF

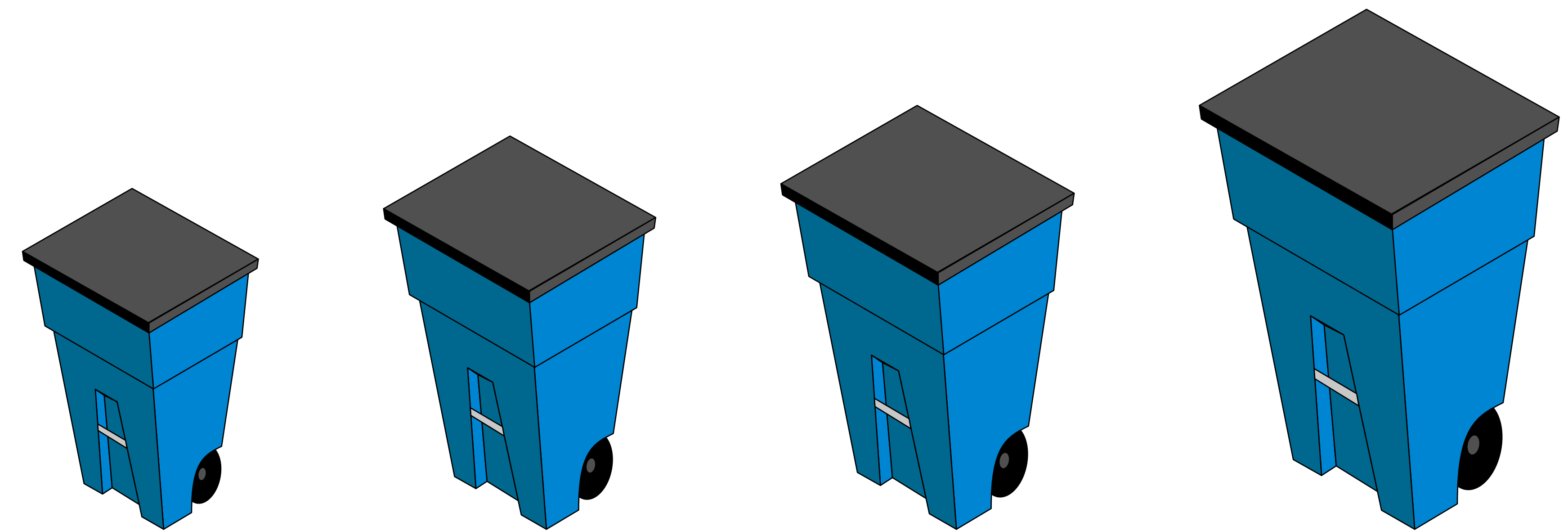

Bin on Dolly

Used for transport within building (normally by custodial staff), and sometimes for disposal locations (for example, in a kitchen)

SIZE	TYPICAL DIMENSIONS		FOOTPRINT
	DIAMETER	HEIGHT	
32 gallon	22"	28"	2.6 SF
44 gallon	24"	32"	3.1 SF
55 gallon	27"	33"	4.0 SF

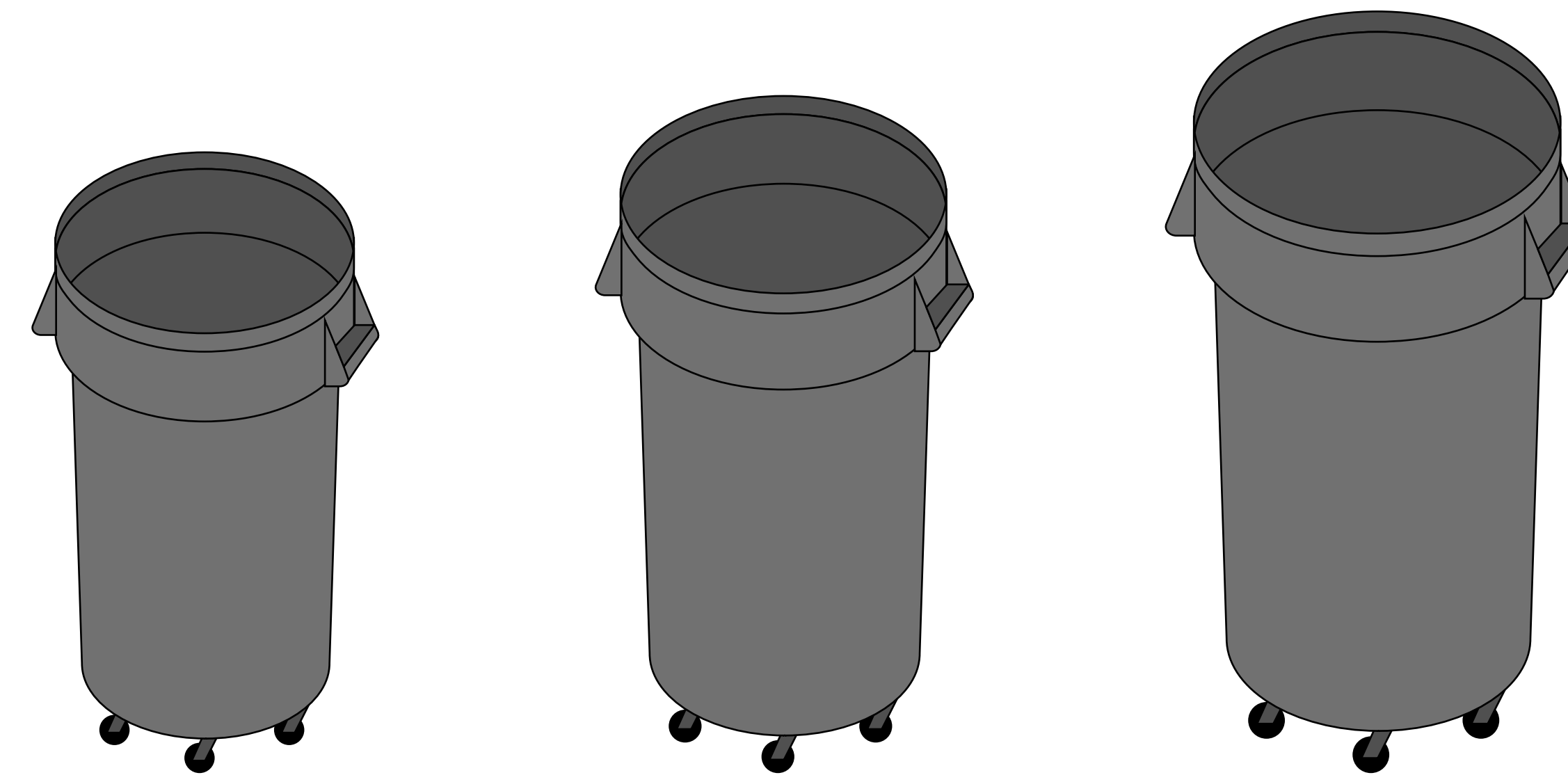

Hamper Bin

Used for transport and storage

SIZE	TYPICAL DIMENSIONS		FOOTPRINT	FOOTPRINT
	DIAMETER	HEIGHT		
8 cu ft	36"	26"	28"	7 SF
16 cu ft	44"	30"	36"	9 SF
20 cu ft	49"	33"	37"	11 SF

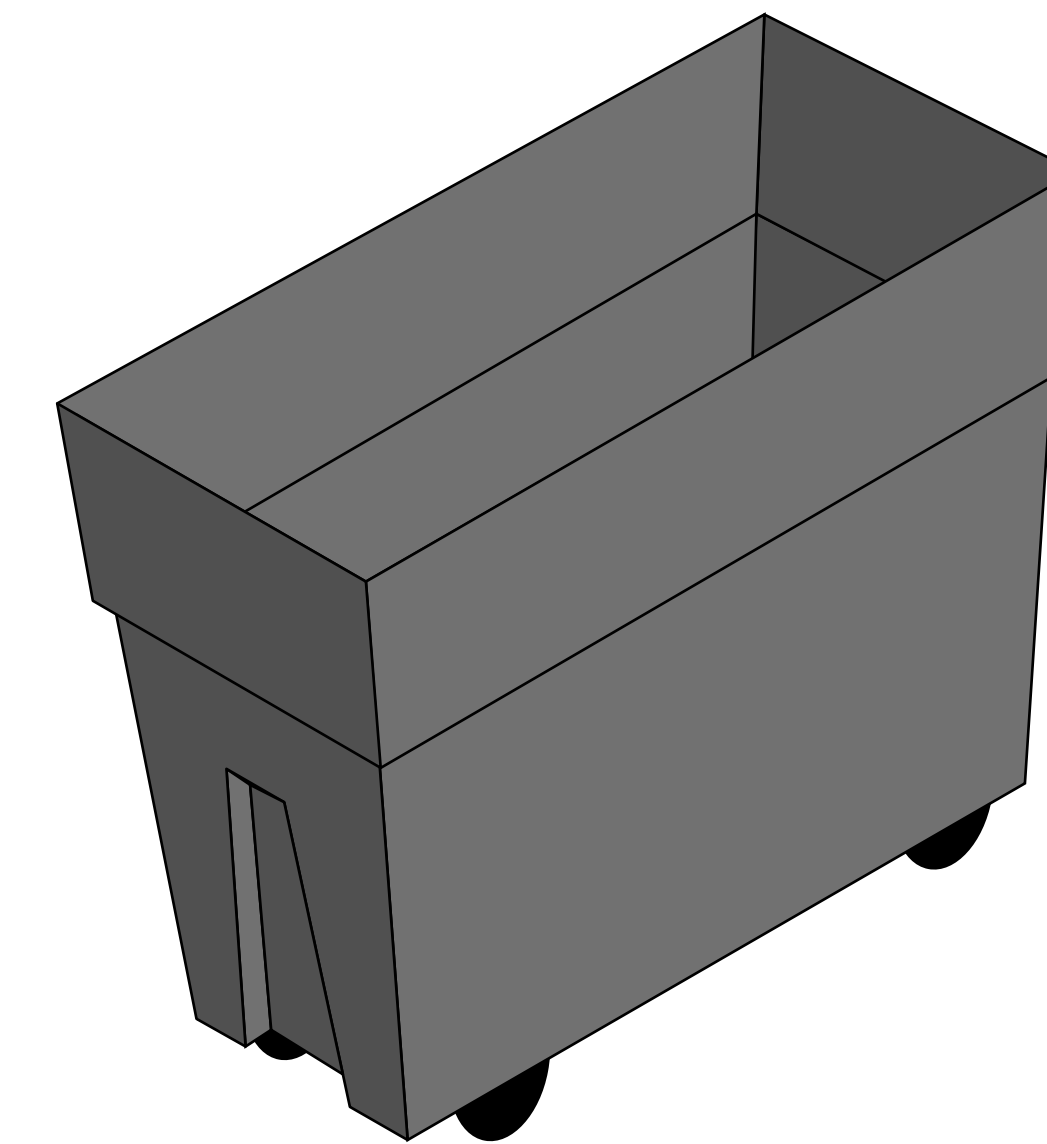

Tilt Truck

Used for transport, contents can be tipped out

SIZE	TYPICAL DIMENSIONS			FOOTPRINT
	LENGTH	WIDTH	HEIGHT	
1/2 cu yd	65"	30"	39"	14 SF
1 cu yd	73"	33"	44"	17 SF
1 1/2 cu yd	80"	40"	48"	27 SF

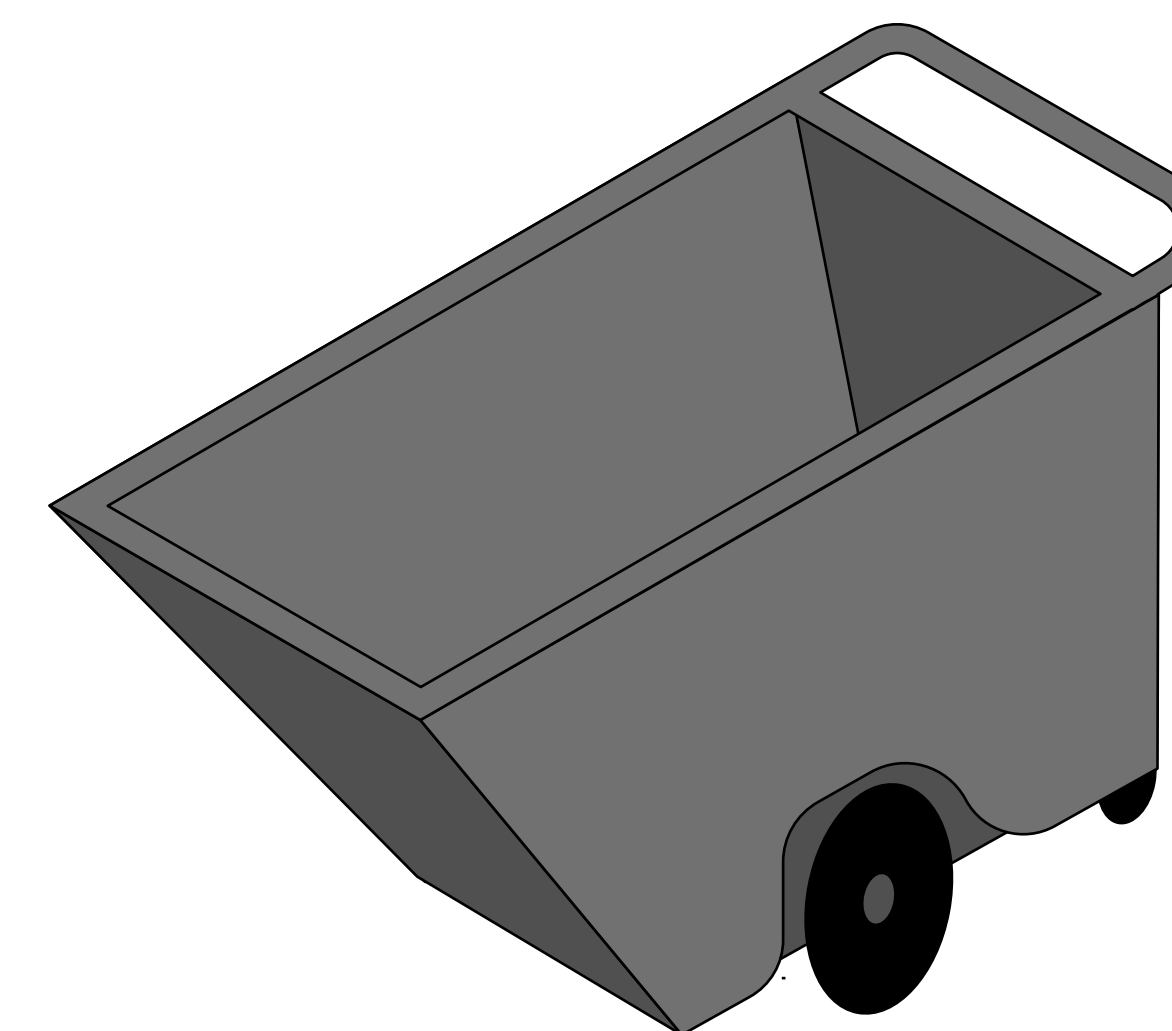

CHUTE OPTIONS

1 Single Chute

Pros:

- Multiple chute doors may be open at one time

Cons:

- Only transports trash (recycling and organics need to be transported by building staff)

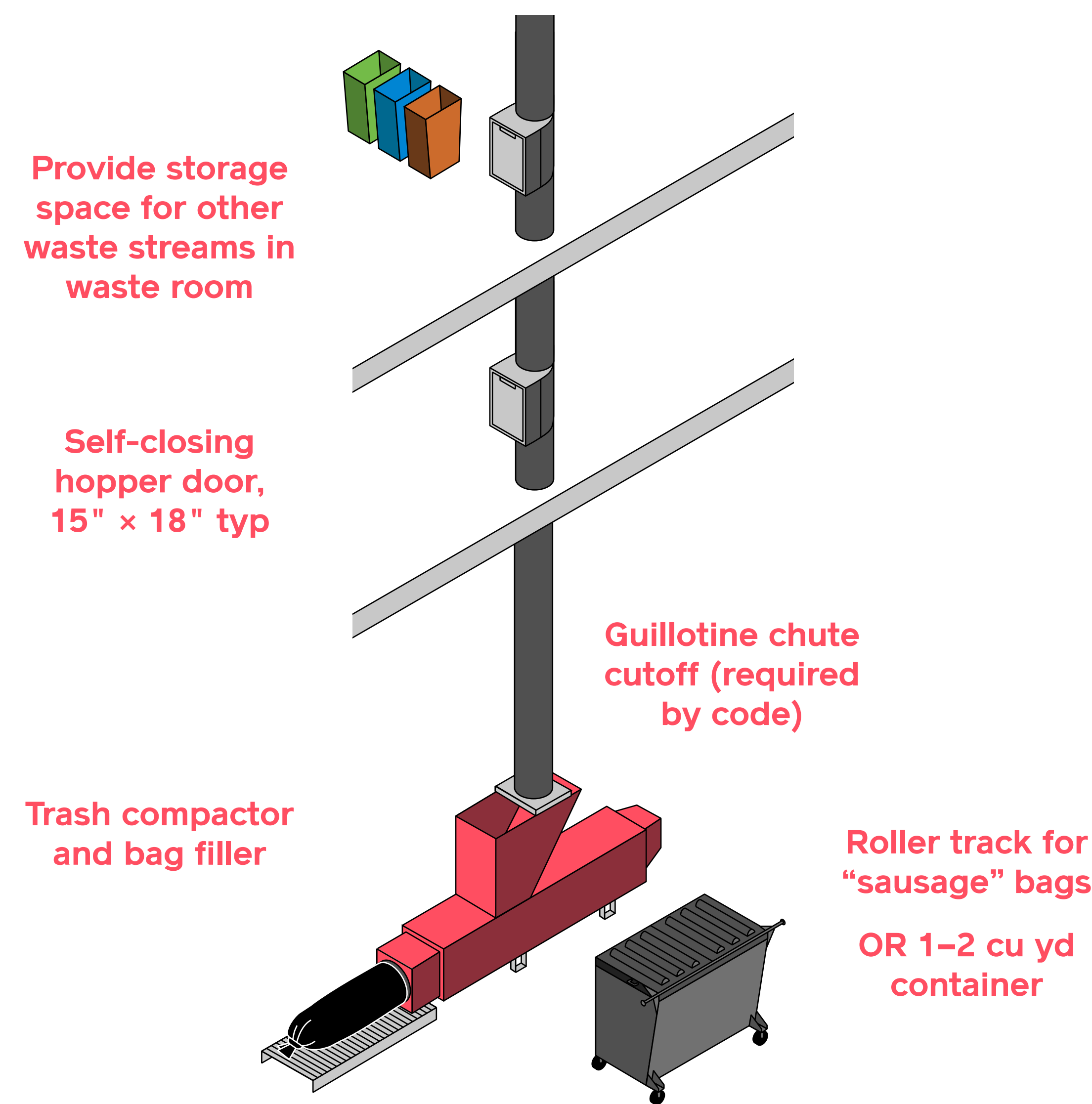

2 Multiple Chutes

Pros:

- Multiple chute doors may be open at one time

Cons:

- Higher cost

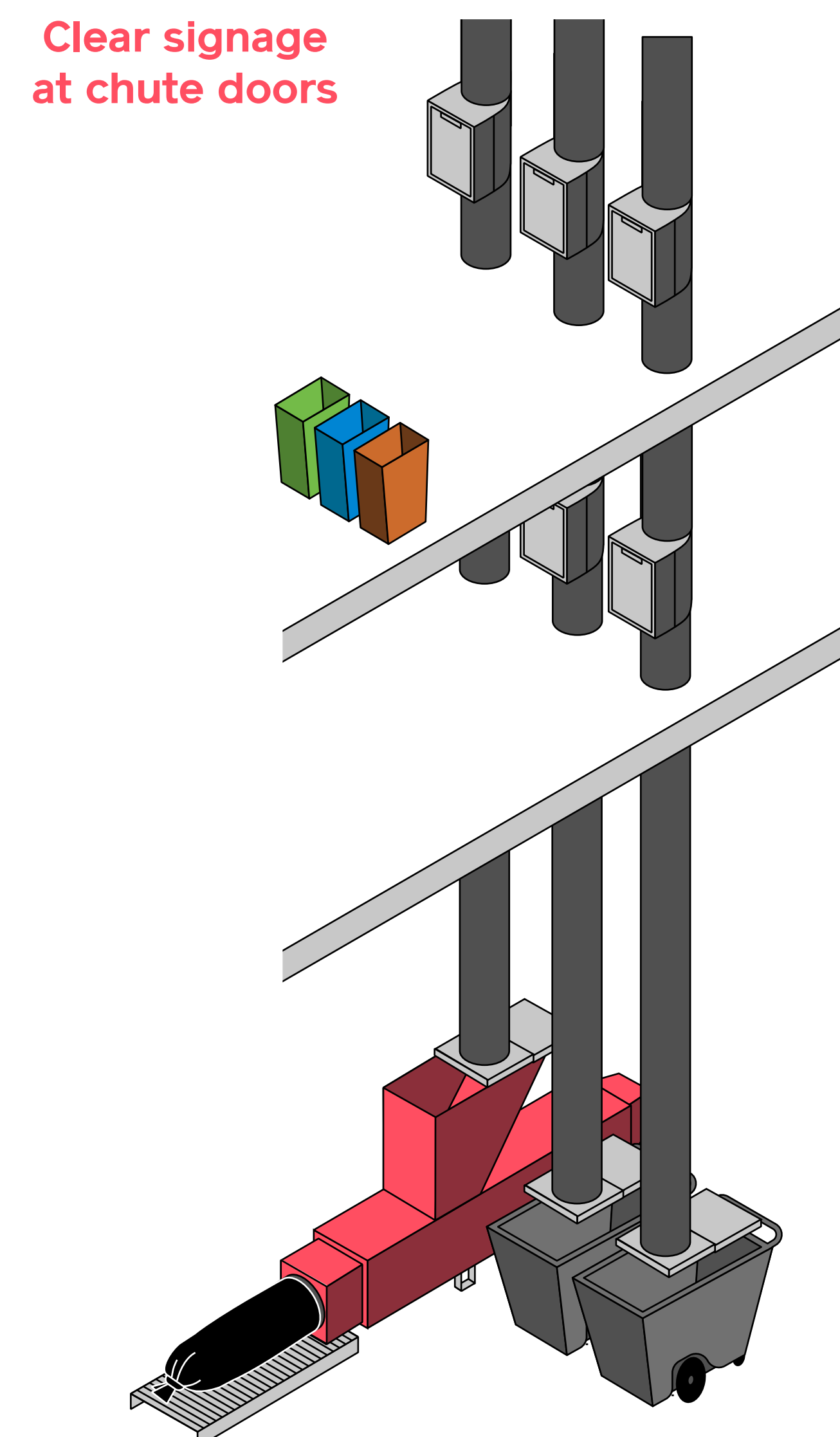

3 Chute with Bi-Sorter/Turntable

Pros:

- Flexibility to add other waste streams with turntable
- Requires less floor area

Cons:

- May be a time delay—only one chute door can be used at a time
- Maintenance required
- Higher cost

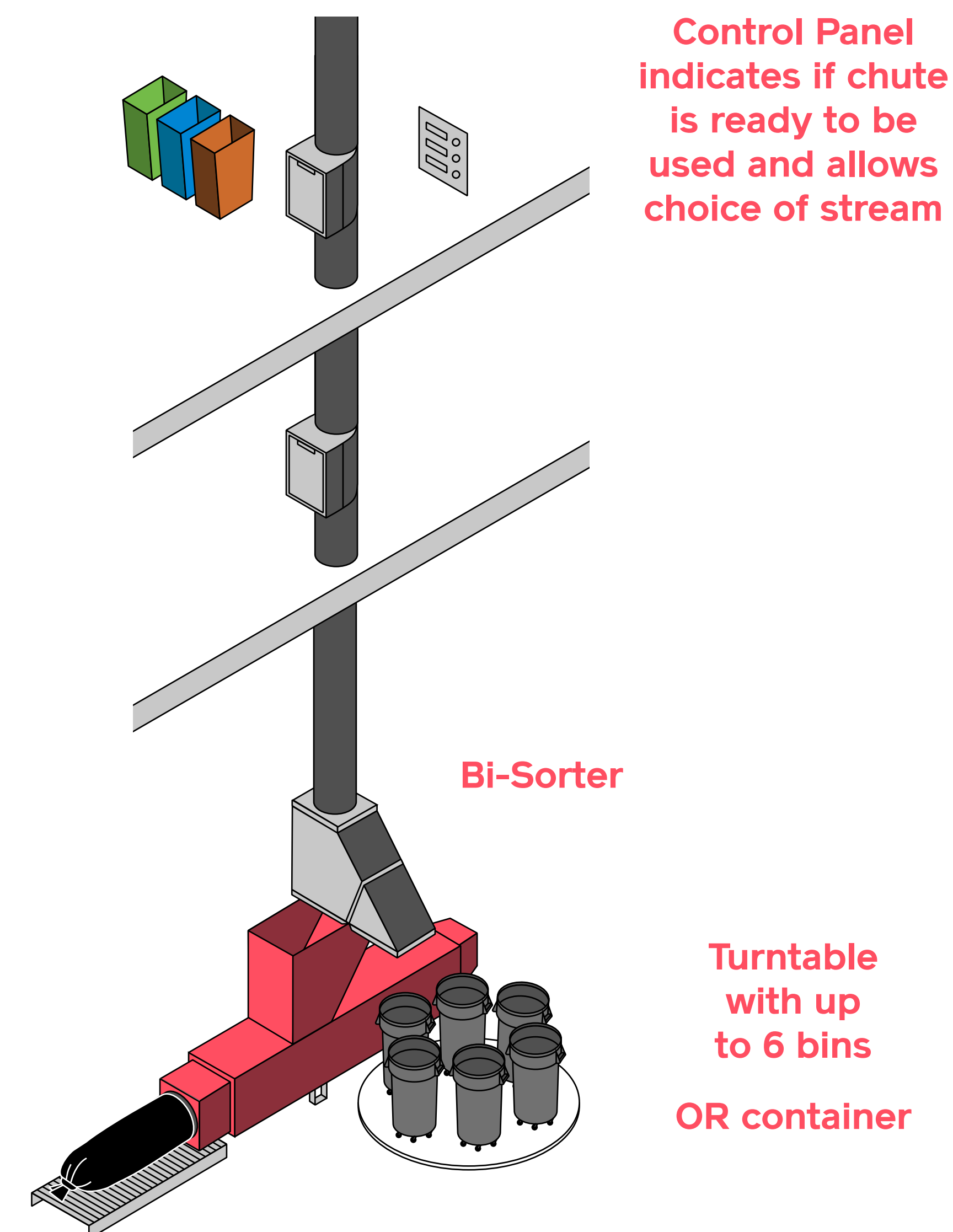

4 Chute with Tri-sorter

Pros:

- Requires less floor area

Cons:

- May be a time delay—only one chute door can be used at a time
- Maintenance required
- Higher cost

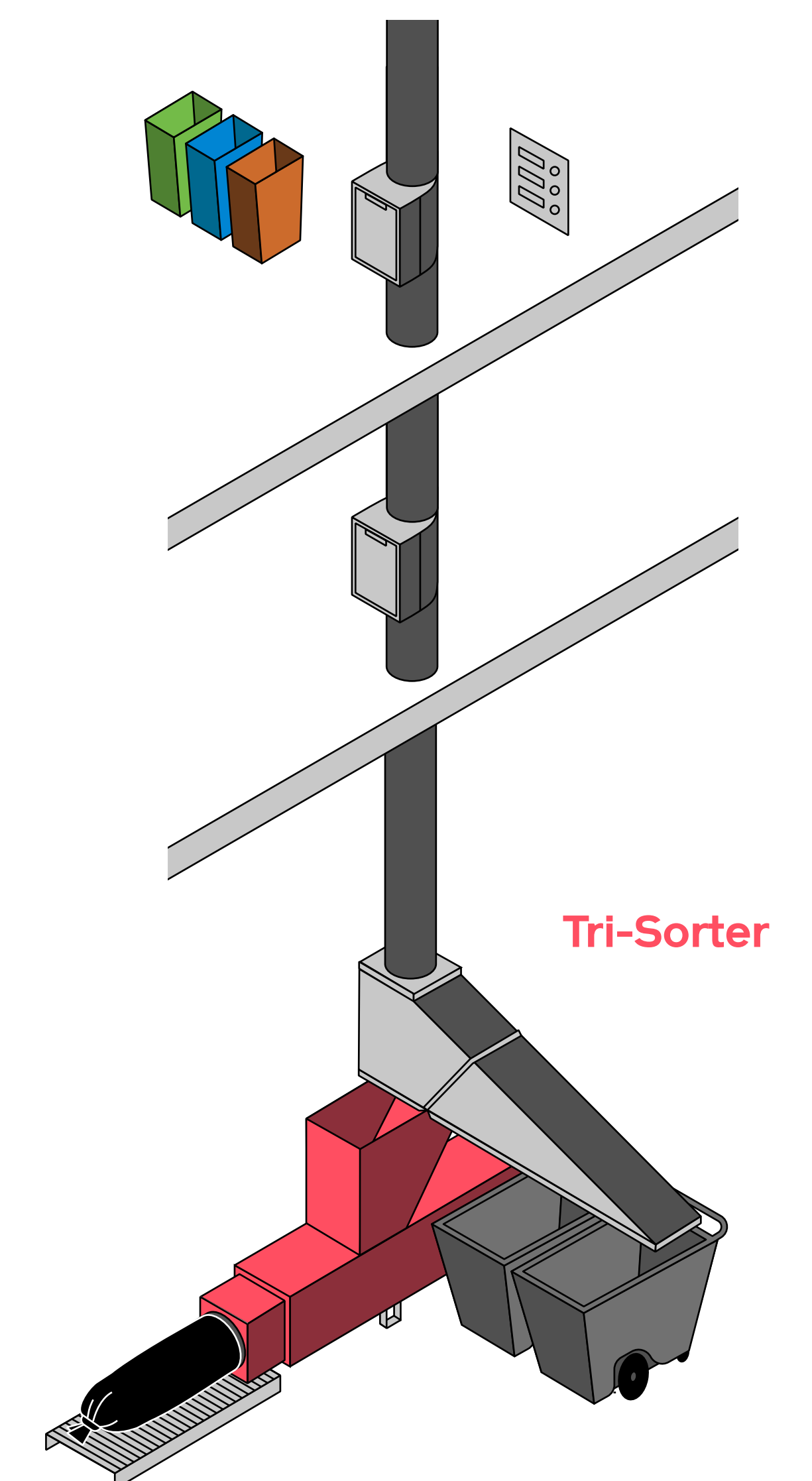

Bottom of chute container options (see DSNY Rules and BC Requirements):

- **Trash chute:** vertical compactor to sausage bag or 1-2 cu yd container
- **Recycling chutes:** Wheeled bins or tilt trucks or 1-2 cu yd containers (or turntable for Bi-Sorter only)

2.04 PLAN FOR COLLECTION

See the [Collection and Urban Design](#) chapter for recommendations on collection typology.

There are many competing uses for NYC sidewalks, including bike racks, street furniture, curb cuts, and tree pits, which may be elongated or include bioswales for additional stormwater infiltration. Designers of new buildings often fail to coordinate these uses with storage space for waste before it's set out for collection. When the quantity of waste that will be set out is known, a designer can often plan a sidewalk to accommodate it, whether the waste is in bags or containers. However, with tall buildings or those creating a lot of waste, there may not be enough sidewalk space to accommodate it, and setting out waste in bags at the curb can block pedestrian traffic. In such a case, the design could allow staff to roll out 1–2 cu yd rear-load containers at collection time (for private hauler pickup), or 20–40 cu yd compactor containers could be placed in a loading dock or exterior space, and buildings could share them (see [Battery Park City case study](#)).

For existing buildings, a lack of interior space for waste storage has led to permanent storage of waste containers along street fronts—in bins, enclosures, and cages—or behind fences, which often detract from the pedestrian sidewalk experience. (See [NYC Rules for Setout](#) infographic.) Another solution that would require changes in city policy is shared collection within the public realm. For shared collection possibilities, see [Best Practice Strategies](#) in Chapter 3.



Ad-hoc residential storage enclosures along street fronts



Elongated tree pit for stormwater infiltration with no space for waste setout

Considerations for collection design:

- Types of containers or bags used
- Timing of collection, and whether interim staging is required
- For wheeled containers: staffing considerations around moving containers back into the building and washing (Note: DSNY does not currently pick up 1–8 cu yd containers from buildings not already receiving the service.)
- Access to collection area
- Coordination with planting zones, street furniture, and sidewalk design
- Coordination with loading zones and curb cuts
- Enclosures and screening if permanent sidewalk storage is provided
- If the building has both private and DSNY collection, plan separate setout areas to reduce confusion for haulers and delineate responsibility.



Staff transferring waste from transport bin to compactor container

2.05 CONSIDER STAFF PROCEDURES

Designers need to consider staffing and maintenance requirements, and it is helpful if they can be involved in developing Standard Operating Procedures (SOPs) which can be reinforced by building management post occupancy.

- Consider staffing requirements and the balance between labor time and first costs. Note first costs can be reduced and maintenance included by leasing waste management equipment rather than purchasing it.
- Collaborate with building management to develop SOPs with clear steps for moving waste streams through the building. Provide information so building management can follow up with education, training and support to increase staff motivation and accountability.

- Signage and visual cues should be consistent throughout the building.
- For existing buildings, draw on the staff’s insight and creativity and collaborate on analyzing the system and devising operating procedures.
- DSNY offers [training for building management](#).
- For building staff within 32BJ union, [training is offered](#).

2.06 PLAN FOR TAKEBACK OF DELIVERY MATERIALS

With the rise in internet commerce, buildings—especially residential ones—are subject to a greatly increased flow of incoming and outgoing materials. Design of entrances should take package deliveries and outgoing packaging into account.

Explore plan layouts to reduce packaging and delivery waste; consider designing loading docks and package rooms to accommodate takeback of crates and packaging.¹⁰

- Provide storage in food service spaces so that suppliers can take back delivery packaging such as crates, wooden pallets and reusable bottles with the next delivery. (See [Park Slope Food Coop case study](#).)
- Provide storage in package rooms for return of insulated cool packs and bags used for grocery and meal kit deliveries. Consider providing a refrigerator if local delivery services will deliver without insulation.



Delivery crates and containers stacked for takeback

2.07 CONSIDERATIONS FOR MULTI-TENANT BUILDINGS

It is not unusual for every tenant in a multi-tenant building, especially manufacturing buildings, to have their own waste hauler. This automatically increases the number of truck trips to the building, producing inherent excess costs and impacts for building occupants and the public. It also limits the ability to use shared equipment in shared building or exterior space. And it increases the complexity of building-wide waste-management operations, since there may not be uniformity with regard to separation requirements, signage, and transparent pricing. Shared equipment can dramatically lower costs and improve waste management—reducing volume and

increasing diversion. Employing a staff member to oversee shared equipment can pay for itself. There are various means to charge individual tenants for usage. (See BPS 2.20.) (See [theMART case study](#).)

- Consider building-wide collection arrangements with a single carter.
- Consider providing shared storage and equipment in multi-tenant buildings. Charge tenants for use rather than a flat fee.
- Ensure that lease language requires individual tenants to use shared storage and equipment, or to provide space for waste storage when shared space is not provided or accessible at all hours.
- Ensure that lease language requires tenants to adhere to waste management rules.
- For residential and commercial buildings with separate collection, separate systems will need to be designed.

Waste Diversion Strategies

Waste diversion is a measure of the proportion of materials that can be diverted from the refuse stream. The degree to which materials are effectively captured at the point of disposal is affected by the relative convenience of disposal and design that makes the user aware of the system to be followed. Education and informational feedback can reinforce this.

2.08 PROVIDE EQUAL CONVENIENCE DISPOSAL (RESIDENTIAL)

Research has shown that leveling the playing field for all daily waste streams increases diversion. If residents have convenient access

to a trash chute but must take recycling and organics to the cellar, they are more likely to throw all waste streams down the chute.¹¹

Where the waste generated will be predominantly one stream—for example, paper and cardboard in a mailroom—then it may make sense to provide only bins for those streams, possibly alongside a general trash bin for incidental waste.

Apartments

Design receptacles for all waste streams together within the apartment.

- Solutions include cabinetry with pullout bins for multiple streams and/or countertop organics caddies. If nothing is designed and built in, the outcome is often a large trash can and inconvenient recycling storage.



Kitchen pullout drawers for multiple waste streams

- Eliminate general-purpose waste receptacles in other rooms, where all streams will be mixed, or provide divided or stacked bins for multiple streams.

Multifamily residential

The building code is written for equal convenience disposal of trash, MPG and paper recycling streams, but not for organic waste. Many existing buildings do not co-locate recycling and trash, and the ease of co-locating organics bins varies with typology. (See [Residential Typologies](#).) Cities with extensive organics programs, such as San Francisco and Milan, have closed chutes and recommend discarding all waste streams at the ground floor, but NYC building code does not always allow for this. Further research is needed to determine the best strategy for building typologies without easy accommodation of organics collection alongside other streams—co-location of bins may not be the best solutions for maximum diversion in some existing buildings. Design for co-location of organics and all waste streams in waste rooms:

- Coordinate with building management to determine if staffing levels allow for minimum daily servicing of organic bins placed in trash rooms. Other strategies to minimize odors include exhaust ventilation and cooling.
- If an organic chute is provided, the receptacle at the receiving end needs to be closely connected to the base of the chute—so a 2 cu yd container is more suitable than a wheeled bin. Organics chutes are not common, but organic material comes down mixed trash chutes and regular chute maintenance

is designed for organic waste sticking to the sides of the chute (with washdown and enzyme treatments). There are concerns that compostable bags are more prone to breakage than regular plastic bags, and piloting of organics chutes is important to address such issues. (See [Grand Millennium case study](#).)

- Existing single chutes can be retrofitted with a sorter system, allowing equal convenience disposal of multiple waste streams.

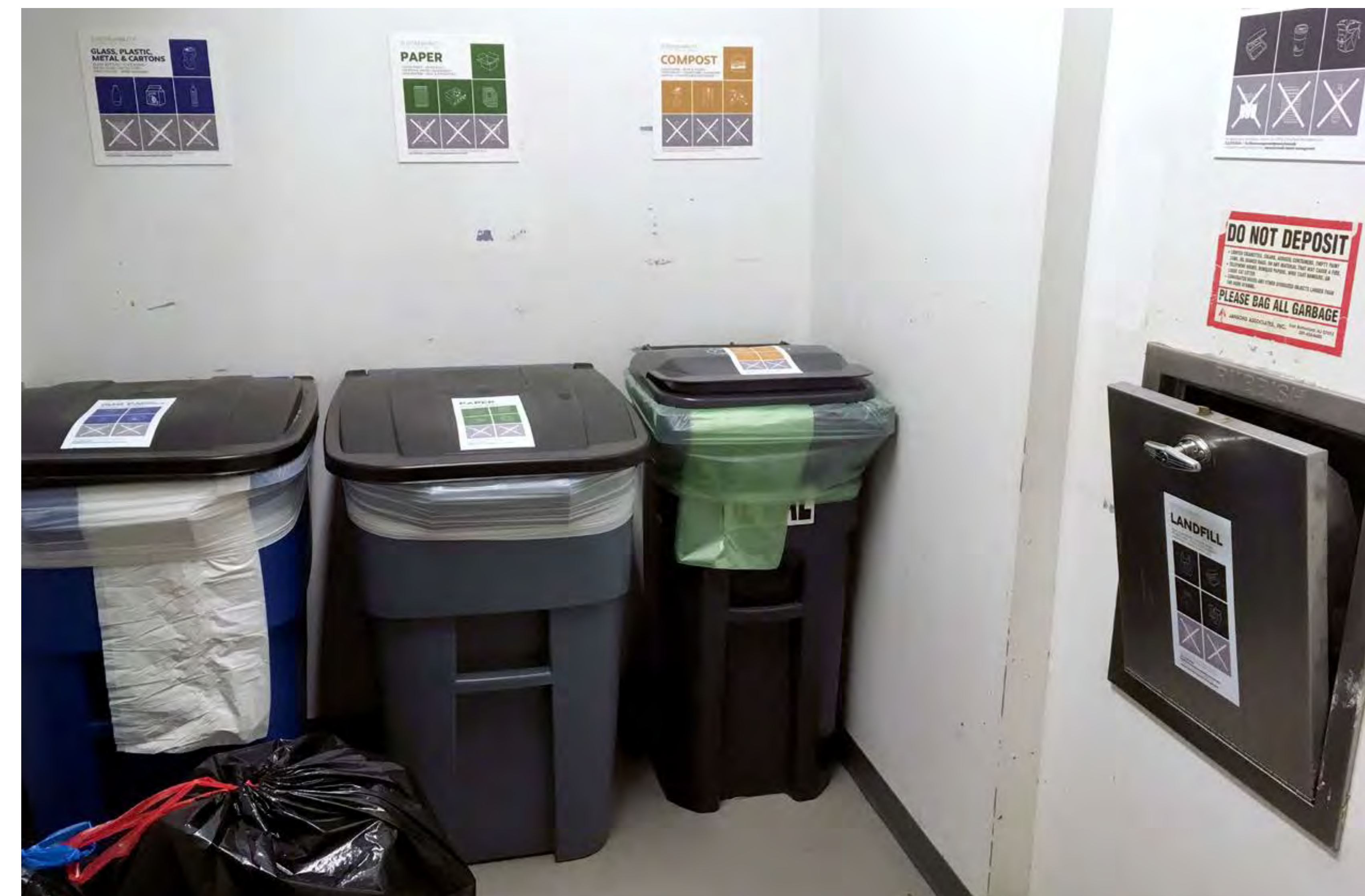

Equal convenience disposal in waste room at The New School dormitory

2.09 PROVIDE EQUAL CONVENIENCE DISPOSAL (COMMERCIAL)

Research has shown that leveling the playing field for all daily waste streams increases diversion. When the waste generated will be largely one stream—for example, organic waste in a kitchen, or paper and cardboard in a mailroom—it may make sense to provide bins for that stream alone, possibly with a general trash bin alongside for incidental waste. Disposal options for all streams need to be provided within the facility.

Offices

Create central waste stations.

- Provide bins for all waste streams in a central area, such as a pantry. Eliminate trash bins at desks, or provide only paper-recycling bins and small desk bins for tissue and wrapper-type trash.
- Ensure that when staff takes waste to a storage location, there are separate bins for each waste stream.



Desk bin for paper recycling, with small trash receptacle



Recycling station with clear visual cues

Restaurant recycling stations

Waste and recycling stations in restaurants are often badly designed and confusing for customers, leading to highly contaminated streams and low diversion rates.

Design recycling stations to accommodate all streams generated within the facility. Streams to consider include:

- Organic waste and compostables
- Recycling: metal, plastic and glass
- Liquids: so customers can empty bottles prior to recycling to reduce weight and make handling easier
- Trash

Typically, customers are discarding only materials bought at the facility, so if streams are not created, separation can be simplified—even down to just organic waste and liquids. (See [BPS 2.10](#).)

Restaurant kitchens

The most common stream in kitchens is food waste, but consideration needs to be given to plastic wrapping and cardboard, and collection of paper, metal and glass needs to be provided in the facility per NYC law. Containers for waste cooking oil should also be provided for and they are typically serviced along with the grease trap. Provide for all food waste generated at all food preparation areas:

- Provide bins for the waste streams generated at each location (this may mean that only organics bins are required in the kitchen, depending on procedures).
- Place organics convenient to sites where food waste is generated, such as food preparation stations and dish areas in restaurants.

Waste storage locations and loading docks

Provide bins of appropriate size at each location where waste is handled:

- Each handling/storage/collection point for waste needs to have appropriate bins for every stream so separated waste does not get mixed up at a later point.
- Bins should be sized for the expected volume of each waste stream—for example, although more recyclable waste than trash is usually generated, a common scenario is to provide a small recycling bin alongside a large trash bin. This leads to lower diversion levels.
- Floor plans that map out bin locations help operational staff place bins in the proper locations each day.

2.10 PROVIDE CLEAR VISUAL CUES AND SIGNAGE

The average person spends a few seconds deciding in which bin to dispose of their waste. With good design, this information can be conveyed quickly via visual cues. Reading requires more time and, in multilingual settings, requires translation. Research has shown that visual cues and signage greatly reduce contamination and increase capture rates.¹²

Use standard signage.

- Use signs and bin labels with clear images (sketches or photos) and internationally accepted color-coding for each stream: blue for mixed recycling, light blue for paper, green for organics and black for trash. [Recycle Across America](#) is one example of standardized signs. Standardizing signage allows easy recognition for the public and employees.
- Make sure signs are consistent throughout a building. In multi-tenant buildings, encourage tenants to use standard signage provided by the building.
- Signs should use similar verbiage to DSNY materials. For commercial buildings, we suggest using international standard colors for paper (light blue) and organics (green), which differ from DSNY colors for residential collection (green for paper and orange for organics). We do this to encourage national or global commercial businesses to standardize across all sites.
- For buildings with DSNY pickup, use the free signage—available in many languages—provided by request from the [DSNY website](#).

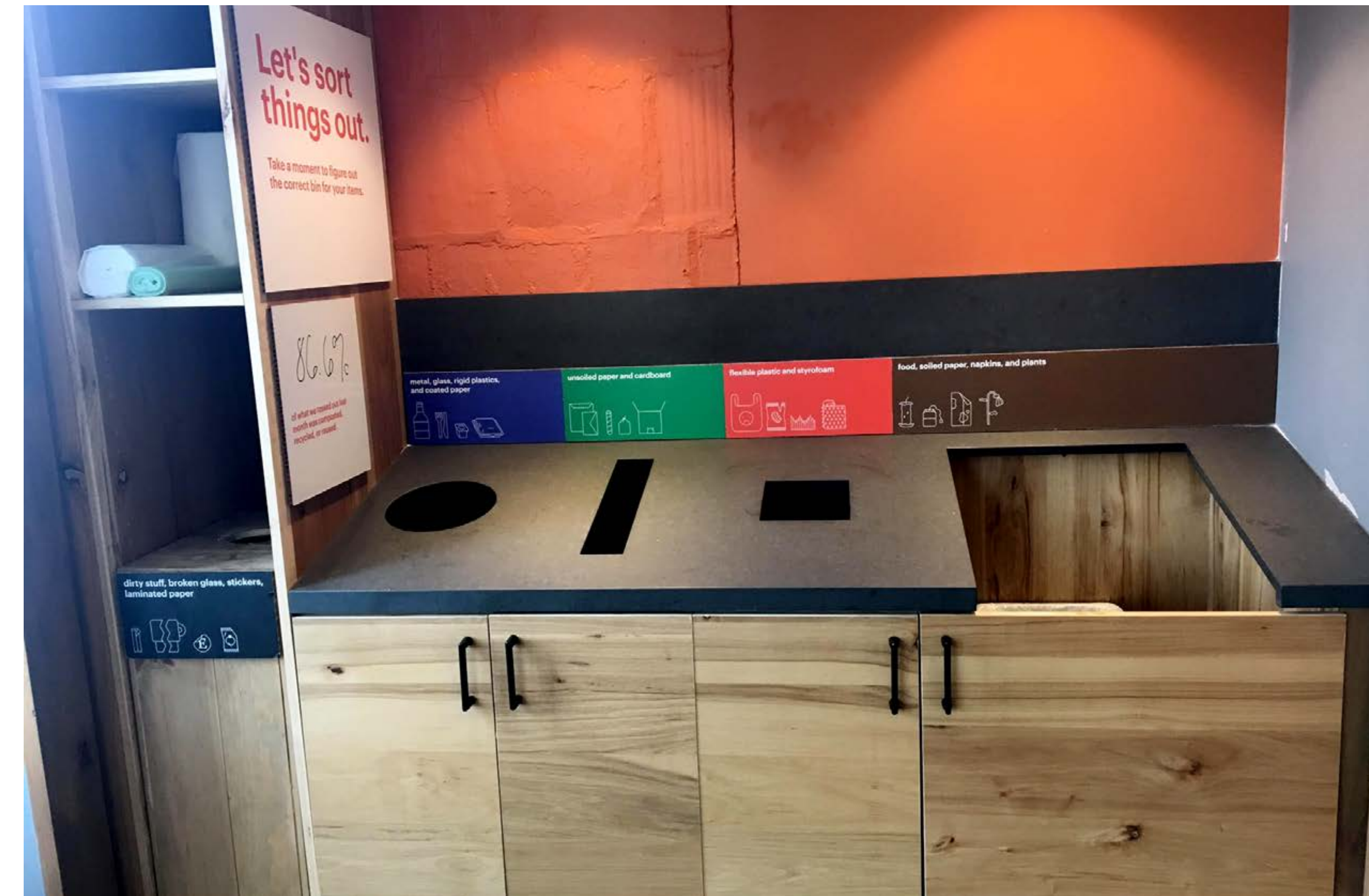

Above:
Clear visual cues and signage for 4 recycling streams (trash is on the left behind a partition, with a small opening)

Left:
Monthly diversion rate displayed prominently at waste station

Design openings to cue user of suitable contents.

Shaped openings can cue users to the appropriate stream and stop entry of other streams. For example, a small circular opening accepts only bottles and cans for recycling, and a linear opening can signify the place for paper. Be aware that openings need to be large enough to accommodate all materials in each stream. For example, smaller holes for bottles and cans will often not accommodate plastic takeout containers or slip openings for paper may be too narrow for a book, frustrating users and leading to poorer diversion.

Use color to indicate waste stream.

- Use standard colors for each waste stream, either DSNY's for NYC (orange for organic waste, green for paper) or international (green for organic waste, light blue for paper).
- Color can be used for the lip of an opening in a waste station, or the color of a bin or lid, as well as for the signage.

2.11 PROVIDE OPPORTUNITIES FOR FEEDBACK

Visual feedback has been shown to change behavior, from research with visible energy meters and dashboards.¹³

Display waste data to change behavior.

Consider displaying waste generation and diversion information at the point of waste generation to change behavior. (See [Etsy case study](#).)

Virtual feedback

Give feedback virtually, through building-wide digital platforms.



Different color bins with clear signage and a lid that needs to be lifted for trash

2.12 DEVELOP AWARENESS AND EDUCATION PROGRAMS

Building occupants who generate waste must be made aware of the system protocol. Combining signage, visual cues and feedback with awareness and education programs can ensure that all waste generators understand the process. Add regular communications to report feedback.

- Consider starting a resident engagement program.¹⁴ (See [Toronto case study](#).)
- For commercial buildings, ensure that new staff is trained and regular staff updates are held. For multi-tenant buildings, ensure that leases require staff training.
- Ensure that leases for residential and commercial buildings include requirements for recycling. (Note that DSNY has [standard lease language](#) available for residential.)



2.13 DESIGN FOR OCCUPANCY (RESIDENTIAL)

Tailoring wastebins to the streams generated is good design that can improve waste handling. Collecting cardboard, textiles and hangers separately in buildings with chutes can reduce chute blockages.

- Provide textile bins in central locations or in the laundry room. Provide bins for ewaste and arrange for separate collection. Apartment buildings can enroll in DSNY's refashionNYC and e-cycleNYC programs.
- In high-end residential buildings, where residents frequently use dry cleaning services, consider providing a rod or stand for return of hangers. This can also help reduce chute blockages.

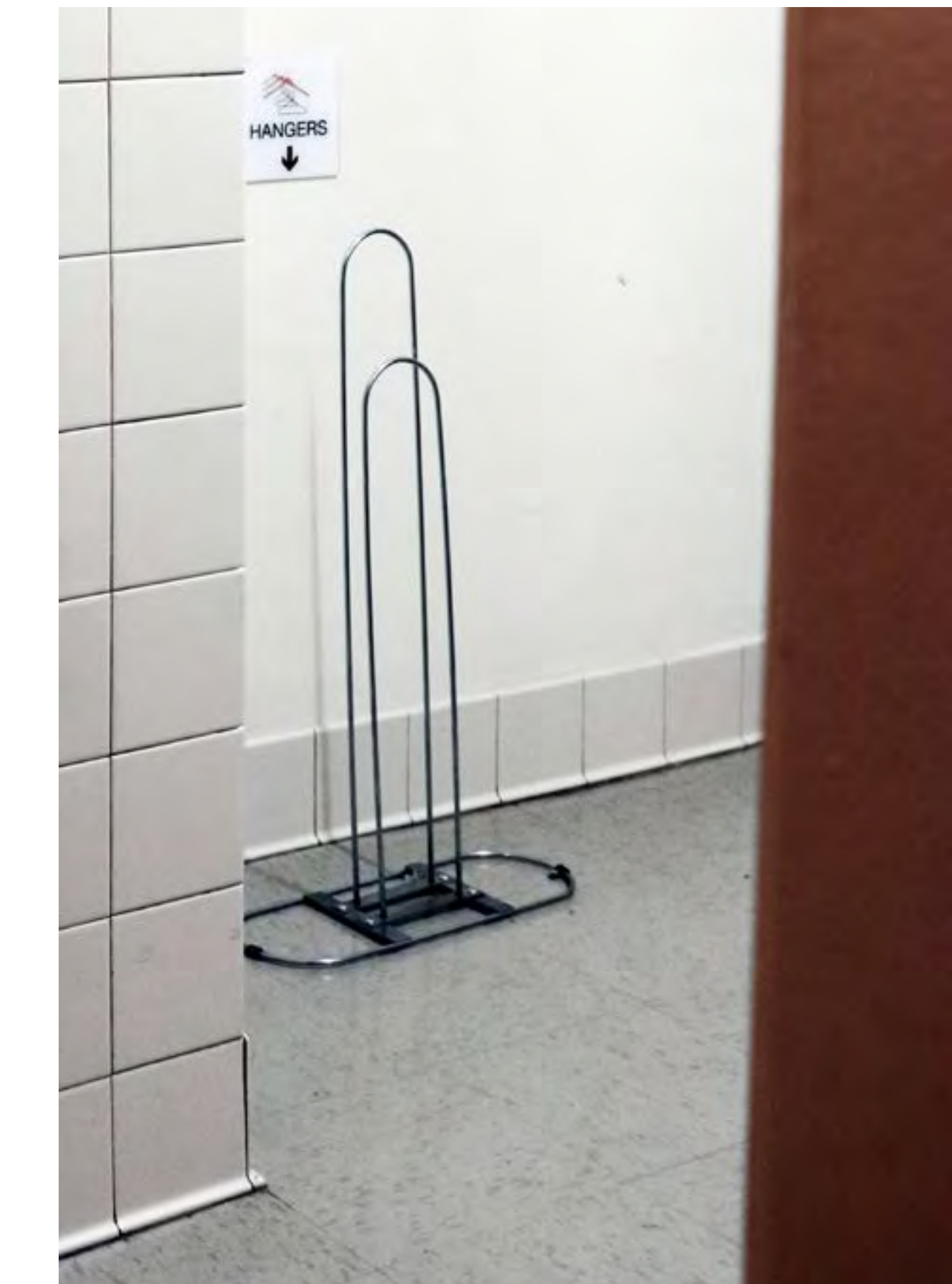

Designing for residential occupancies: refashionNYC textile bin in laundry; e-cycle cart; rack for hangers

- In buildings likely to receive many deliveries, consider adding space for cardboard and a means to break it down. (See [StuyTown case study](#).)
- Providing collection containers for waste items outside DSNY’s domain—such as batteries, bulbs, thermometers and syringes—conveniences residents, protects staff and ensures safe diversion of the materials. Building management does become responsible for the waste, so determine the types of hazardous waste to include.¹⁵ Some residential buildings also collect used cooking grease, Brita filters, plastic film and pouches, and other items.
- Place waste bins for common streams at appropriate locations, such as paper and cardboard collection in mail- and package rooms and textile and plastics recycling in laundry rooms.

2.14 DESIGN FOR OCCUPANCY (COMMERCIAL)

The waste streams of commercial and institutional buildings vary greatly with occupancy. Separating and providing collection opportunities for the streams generated can improve waste diversion. (See [BPS 2.09](#).)

- For restaurants, consider storage for used cooking oil, which can normally be collected by the same hauler that cleans grease traps.
- For food and industrial waste streams, explore the possibility of beneficial reuse for a particular portion of waste stream. There are many examples of food waste generated by one business being repurposed by others. See [ReFED website](#) for innovators that use surplus bread to make beer, and others that use spent grains from beer to make granola bars.

- Consider if materials can be removed from the waste stream, or waste can be reduced through procurement decisions.
- Perform a waste audit to understand where discard streams are coming from, and consider whether these can be prevented from entering the building. Etsy did a waste audit and saw a lot of packaging waste came from takeout lunches and beverages. It now provides reusable cups for staff to bring to local cafés (See [Etsy case study](#).)



Fat and bones from meat packers is separated and used to make soap, industrial cleaners, chemical lubricants and pet food; Toast ale is made from surplus bread

Waste Reduction Strategies

2.15 PROVIDE SHARED EQUIPMENT AND SERVICES

In the circular economy, sharing is key, and it can be promoted through building programming. (See [C&D BPS 2.26.](#))

Consider providing shared equipment.

Multifamily residences often offer equipment within shared spaces, such as weights in a gym, toys in a playroom and barbecue grills on a roof terrace. Consider further amenities, such as a shared goods library, which reduces the need for a vacuum cleaner, drill and air bed in every closet.

Design for service, to reduce the amount and frequency of items purchased.

Provide maintenance services such as cleaning, laundry and repairs within the building so there are fewer—but higher quality and more efficient—appliances.

2.16 REDUCE MATERIALS CONSUMPTION.

Packaging composes a substantial percentage of waste, and food packaging accounts for about two-thirds of the total volume of packaging waste. Washing reusable containers leaves a much smaller environmental footprint than using disposable packaging does (see [City of Portland study.](#)) When reusable containers aren't an option, choosing compostable materials can reduce the volume of waste and its environmental footprint. Paper accounts for 37% of NYC's commercial waste.¹⁶

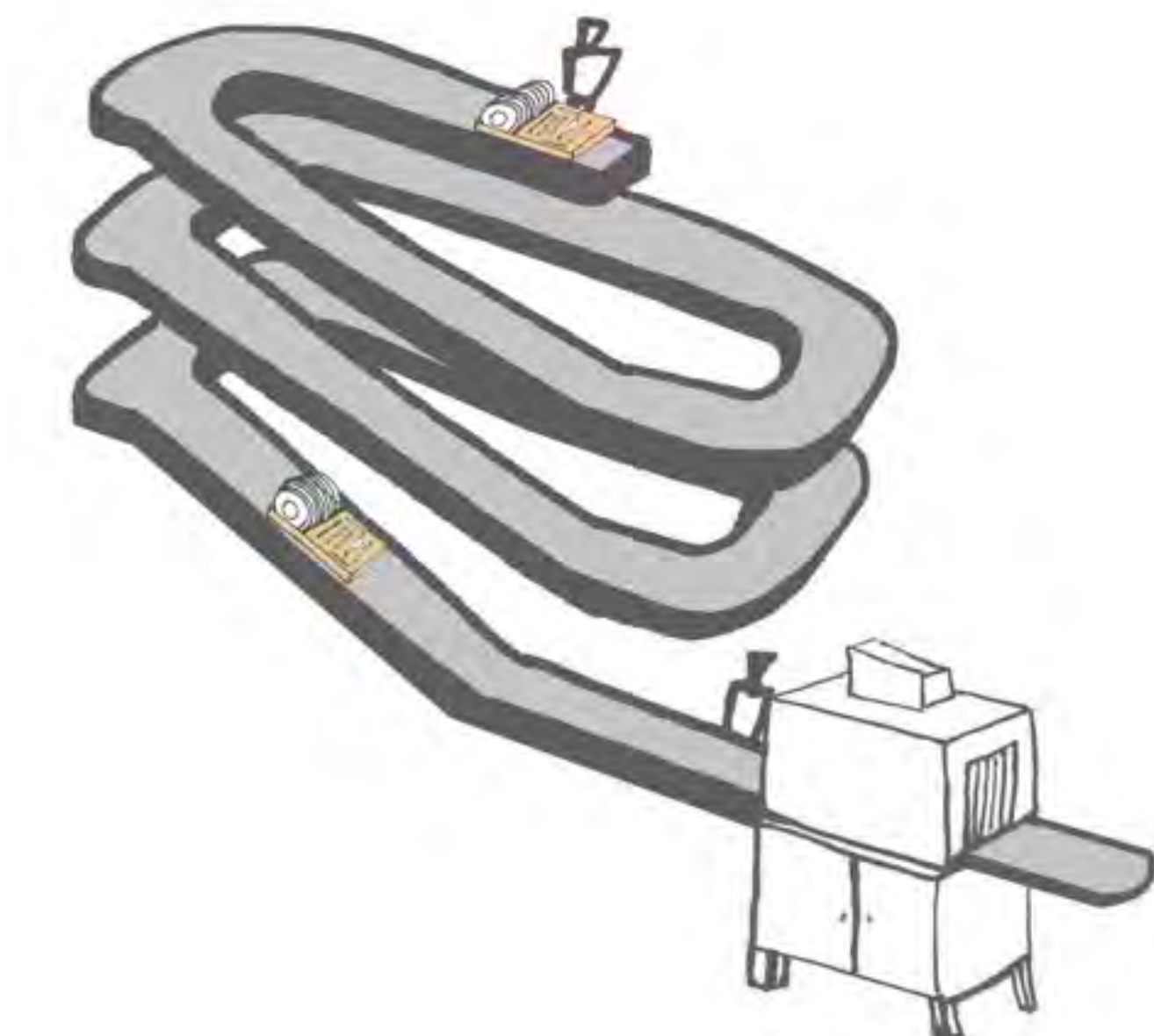

This dish carousel transports dishes, via a conveyer belt, from the second floor restaurant down to a dishwasher in the cellar.



Reusable 'GO Boxes' are used in Portland, Oregon

- Provide water fountains and bottle fillers, drinks on tap and bulk snacks rather than vending machines or packaged goods.

Provide compostable dishware and utensils.

Coordination with the waste hauler is required to ensure that the final destination facility for organics accepts compostables. Anaerobic digestion facilities do not generally take any compostables (these are filtered out with other contamination and disposed), and some compost facilities will not take compostable bioplastics. If compostables are a high proportion of overall organic waste larger wheeled bins can be used for in-building transport and collections (64–96 gal.) because compostables are lightweight. Organic pretreatment equipment generally will not accept compostables. (See [BPS 2.24.](#))

Design to reduce the use of packaging and disposable tableware.

- Program restaurants and cafeterias with dishwashing facilities and use reusable dishware and fountain drinks rather than bottled drinks and disposable plates and utensils. Dishwashing rooms can be remotely located and dishes conveyed by dish conveyors which can even take dishes down multiple stories to less valuable below grade areas. Dish conveyors also put separation of waste in the hands of staff which simplifies separation for customers and reduces contamination.
- Provide reusable to-go containers which customers can take with them and then return to the restaurant or drop in designated bins. (See [Columbia University case study.](#)) Provide space for a bin for returns of containers and dishwashers if washed on-site, or access for a third party to pick up and wash off-site.

Provide compostable dishware, cups and utensils (paper compostables are environmentally preferable to bioplastics). In a food service environment, such dishware, cups and utensils can greatly simplify waste collection as all discarded items may fall into one waste stream: organic waste. If a large generator is using compostables, a compactor would be recommended for volume reduction.

Design to reduce the use of paper.

- Design for digital information with digital displays and smartboards rather than for usage with easels, printers, copiers and file cabinets.
- Provide energy-efficient hand dryers rather than paper towels. Studies have shown that these dryers, especially the high-efficiency ones, have a lower environmental impact.

FOOD SERVICE DESIGN CONSIDERATIONS

1. Refrigerator includes **storage for food donations**. Locate food donation storage for convenient collection. 2.18
2. Provide **food waste tracking system with scale**. 2.17
3. Organic waste collection in kitchen: replace refuse bins with **small organics totes**, and **countertop organics caddies**. 2.09
4. For volume reduction, consider **food waste pretreatment equipment**.
5. Provide **dishwashers** and consider path from dish room to dining area. For larger operations consider dish carousels. 2.16
6. Accommodate **cooking oil collection and storage**. 2.14
7. Delivery considerations: Where possible receive deliveries in **reusable crates** that the vendor collects. 2.06
8. Design **customer recycling stations** with clear visual cues and signage to accommodate all waste generated, including liquids. 2.10

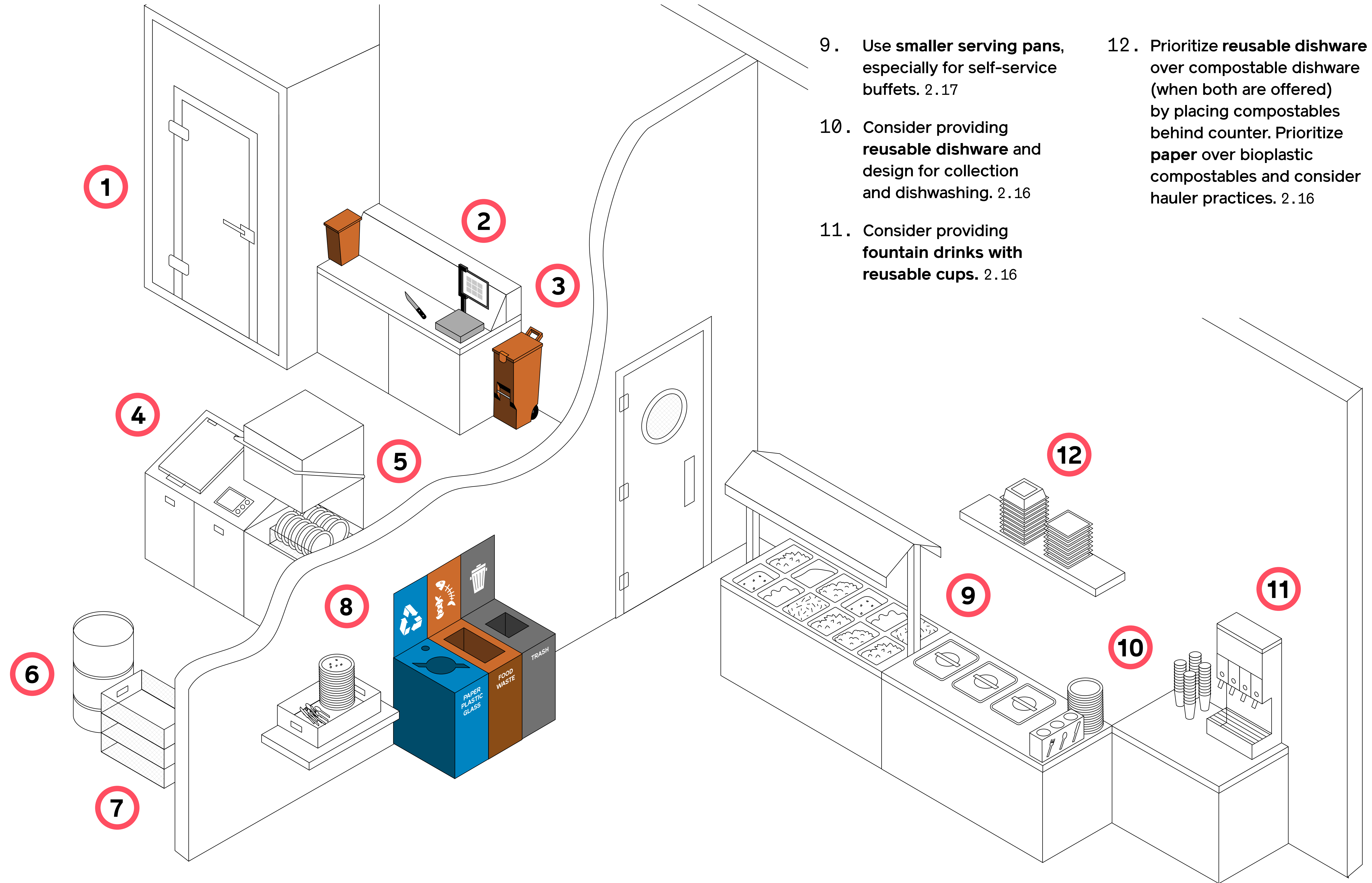

9. Use **smaller serving pans**, especially for self-service buffets. 2.17
10. Consider providing **reusable dishware** and design for collection and dishwashing. 2.16
11. Consider providing **fountain drinks with reusable cups**. 2.16
12. Prioritize **reusable dishware** over compostable dishware (when both are offered) by placing compostables behind counter. Prioritize **paper** over bioplastic compostables and consider hauler practices. 2.16



Buffet with small buffet pans and reusable dishware

2.17 REDUCE FOOD WASTE GENERATION

Food waste is a big issue in the US, with 30%–40% of all food being wasted, mostly in consumer-facing businesses such as restaurants and grocery stores and homes. When food is wasted, all the energy, water and labor involved in farming, harvesting, processing, packaging, cooling and transporting the food is wasted as well.

Design food storage to reduce waste.

Design kitchens to minimize spoilage by avoiding food loss with visible storage, shallow refrigerators and refrigerated drawers.



Reducing food waste generation through weighing waste manually or use of a digital software (Lean Path shown)



Design food display to reduce waste.

- Design buffets for minimal waste (smaller buffet pans or rounds) versus traditional large “hotel pans.” Buffets in typical food service environments can be major sources of waste, especially if self-service; once consumers have scooped from a dish, the food safety chain is broken and leftovers can’t be reused or donated.
- Reduce serving waste in restaurants by using smaller plates and trayless dining to lessen overconsumption and leftovers by diners.
- Design displays for food in grocery stores so the oldest food is purchased first and size displays so there is a quick turnover of displayed food.

Design for equipment to track food waste to change purchasing decisions.

- Provide food waste tracking systems in food businesses. Food waste tracking and analytics can reduce food waste in consumer-facing businesses by up to 35%. A scale with an input screen to track food waste is placed adjacent to the organics bin. Software analyzes the data and gives insights and strategies for waste reduction. Digital systems include LeanPath, Winnow and Phood; manual tracking systems can also be used.¹⁷
- The technology is still new, but refrigerators are being developed for residences that can help owners track food using camera technology to minimize waste.

2.18 FACILITATE DONATION AND REUSE

After reducing consumption to match need, reuse of items is the next strategy down on the waste hierarchy. Building design can facilitate reuse of unwanted items, and this is often done informally—the front stoops in brownstone neighborhoods make perfect display shelves for selling or giving away unwanted goods. In larger buildings, cellar space is sometimes used to allow reuse of larger discarded items by others in a building. However, as space is normally at a premium, it may be more convenient to share available items digitally, through resident portal systems such as BuildingLink or ActiveBuilding. When inadequate space is provided for bulk items awaiting collection, crushing equipment may be used instead, destroying the items and preventing reuse. Food donation, mentioned above, requires special consideration.



Brooklyn stoop sale

Design for storage for bulk items.

Provide a physical space or online platform to allow reuse of items by others within a building and enough storage space for items awaiting pickup by a reuse business or charity.

Design for access to and refrigeration of food donations.

- Enable donation of perishable food by providing refrigerated and dry storage in a convenient spot, especially if pickup needs to happen after hours. For more information on setting up a food donations program, consult the [NYC Department of Health and Mental Hygiene's Guide for Food Donors](#).

- Work with donation-matching companies that help find local partners for restaurant food waste.¹⁸
- Consider donating refrigerators in residential buildings so residents can share food that might otherwise go uneaten.

2.19 DESIGN TO INCORPORATE FINANCIAL INCENTIVES SUCH AS SAYT (RESIDENTIAL)

Metering and charging for water usage and electricity usage has been shown many times to significantly reduce water and electricity use, and it makes sense that the same is true for waste. Pay-as-you-throw schemes have been shown to reduce waste and increase recycling in other cities, and DSNY is currently studying implementation of a save-as-you-throw (SAYT) initiative within NYC. If the financial benefits are only applied at a building level and not directly related to the amount of trash an individual household produces, the personal incentive will be missing. Even if SAYT is not implemented, buildings can be designed to reduce waste and increase diversion through financial incentives.

Design so financial incentives can be applied at household level.

- Consider strategies that track waste generation to individual households. Strategies include requiring an ID tag to open a chute, with incentives for reduced usage especially of a trash chute. If a SAYT system involves purchasing special bags, then it may be necessary to set up cameras or publically visible access sites to discourage the use of unauthorized bags.
- Other less accurate but simpler means to charge for waste generation per user could include financial incentives

linked to the frequency a resident enters a waste room, through data connected to the resident's digital key.

2.20 DESIGN TO INCORPORATE TRANSPARENT PRICING BY STREAM (COMMERCIAL)

Design commercial buildings to track individual business waste, and provide feedback

- In multi-tenant commercial buildings, consider systems that weigh and track waste with scales at loading docks with combined compactors and containers. (See [theMART case study](#).)
- In commercial buildings consider having maintenance staff use hampers with integrated scales and input screens to track waste, using free software such as Divertsy by Etsy. (See [Etsy case study](#).)

Volume Reduction Strategies

Equipment that reduces the volume of waste streams can reduce the area required to store and set out waste, labor costs and will reduce the number of trucks needed to collect the waste, reducing environmental impacts. It can also make the job of handling waste more efficient and less dangerous. Because organic waste is up to 90% water, it is heavy to move and expensive to cart away, but there are opportunities for substantial volume and weight reduction. On-site waste pretreatment is typically used in commercial buildings only. (See [BPS 2.24](#).)

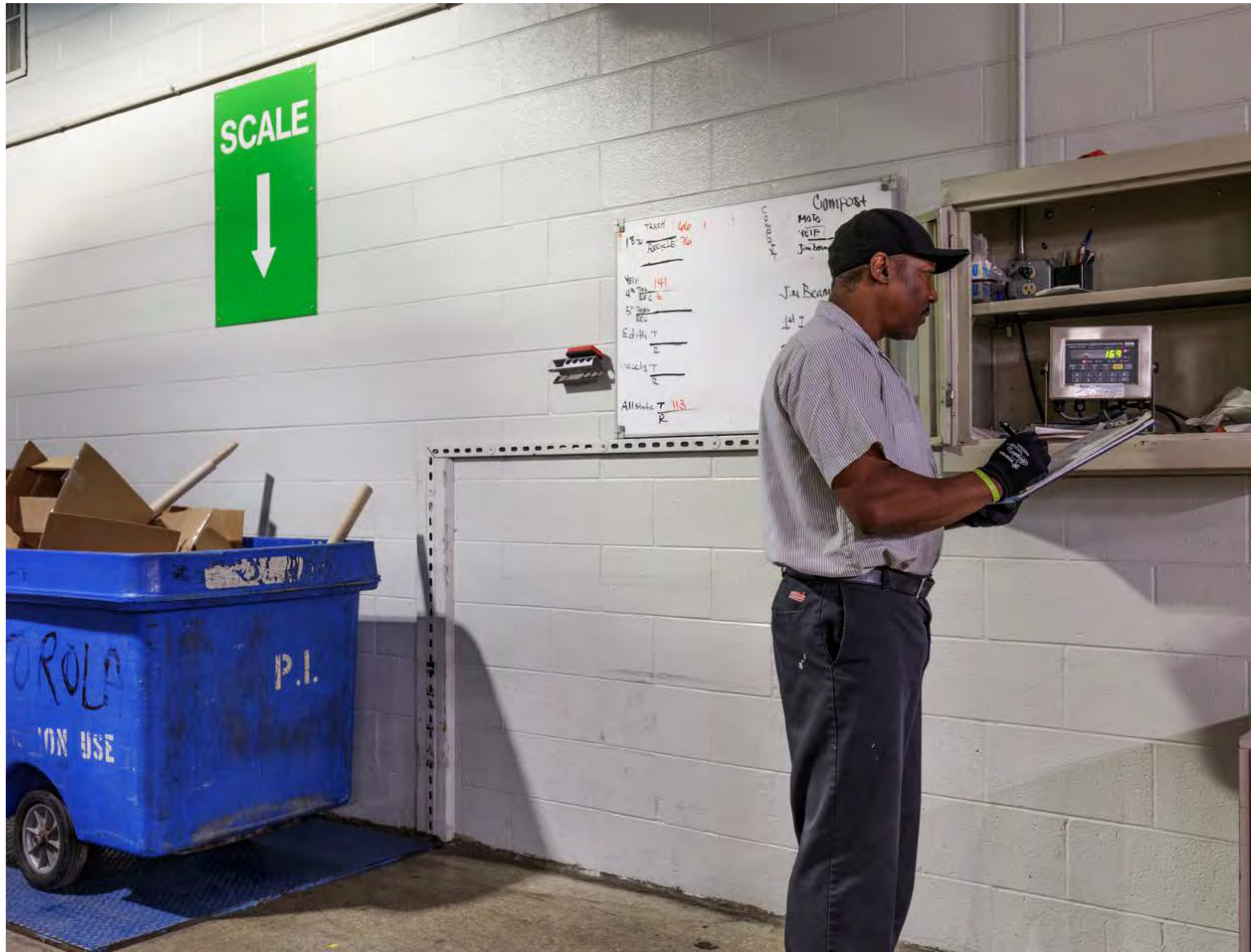

Waste is weighed at central storage area

Careful consideration should be given to the factors below before equipment is specified, as it is not suitable for every situation.

Equipment Types

- Compactors (trash, cardboard, metal, plastic and glass recycling, organics)
- Balers (cardboard, metal and plastic, including film)
- Crushers, shredders and grinders (glass, paper, plastic)
- Organic waste treatment (organic waste, typically food waste)

Considerations include:

- Cost and maintenance
- Waste stream suitability
- Compaction ratio
- Labor and training required
- Size and clearances
- Power requirements and energy usage
- Size and collection method for waste output
- Digital capabilities, for automatic service and data on amount of waste generated.
- For multi-tenant buildings, whether equipment is centralized or within individual tenant space.

2.21 VOLUME REDUCTION EQUIPMENT: RESIDENTIAL COMPACTORS AND BALERS

Compactors

Compaction ratios for compactors are typically 3:1 or 4:1 for trash, and 3:1 for cardboard and recycling.¹⁹

Chute-fed compactors

Compactors are required for trash for larger residential buildings (See [Building Code](#).) Typically the waste chute feeds directly into the compactor which packs trash into a long tube of plastic. Staff tie off the bag at regular intervals, and cut them into “sausage” bags. (See [Chute Options](#).) Chute-fed compactors can also pack into front- or rear-load containers—typically 2 cu yd—which reduces labor significantly. There are additional considerations for containers (see [Truck Collection](#)



Cardboard and recyclables spilled out into exterior areas before a baler was installed in the waste room.



Stationary compactor with hopper feed (collected by DSNY)

Typology 3). Currently, DSNY only collects front-load containers from grandfathered buildings already receiving container service.

Stationary compactors

DSNY has roll-on/roll-off (RoRo) container specifications for 35 cu yd container compactors, which can be used for trash or paper and cardboard. DSNY recommends a trash compactor container in buildings with more than 500 apartment units.

The compactor is typically ground mounted with a separate mechanical unit. It automatically lifts 1–2 cu yd containers or tilt trucks and empties them into the compactor. The maximum size of the compactor is 35 cu yd, and it is picked up by a roll-off truck when full and returned empty.



Bales are heavy and can be transported by hand truck, or for DSNY collection smaller bales that weigh under 60lbs can be made. (Bramidan baler pictured)

Balers

(See [BPS 2.22](#).) Cardboard and metal and plastics can be baled. For DSNY pickup, bales need to weigh under 60 lb. Compaction rates vary but can be up to 8:1 for cardboard and 5:1 for plastic and metal recycling.

2.22 VOLUME REDUCTION EQUIPMENT: COMMERCIAL COMPACTORS, BALERS, CRUSHERS AND GRINDERS

Compactors

Self-contained compactors

The most common compactors used in NYC commercial buildings are 30 or 35 cu yd self-contained compactors, though options range from 10–40 cu yd. These can be used for wet or dry waste. The compactor is part of a self-contained unit that is taken away by roll-off truck when full and brought back empty. They are typically located on a loading dock with a raised platform, allowing waste to be tipped into the compactor. If there is no dock platform, compactors are normally side loading or have cart tippers. The compactors can also be fed through a chute—for instance, when the compactor is outside and the feeding point is inside. Compactors can be split into two sections to compact two waste streams: say, trash and recycling. They can also be customized for the size constraints of a loading dock.

Compactor containers can be shared between tenants in a multi-tenant building and accessed with an electronic tag when waste is weighed prior to putting in the compactor, enabling cost to match weight

of waste generated. Sensors can also automatically notify the service company to come and collect the full compactor. Considerations for interior compactors include:

- Headroom: Space and clearance for servicing and truck access for removal
- Method of filling: Provision of a height difference, for example from a loading dock platform, allows material to be tipped into the compactor from a tilt truck, avoiding the need for manual lifting of bags or a cart tipper.
- Weight requirements
- Staffing: must meet ANSI and OSHA best safety practices

Stationary or breakaway compactors

These are commonly used for cardboard and other dry good compaction. The compactor is ground mounted and feeds compressed material into a large 10–40 cu yd container that is picked up by a roll-off truck when full.

Breakaway compactors are also serviced by DSNY, which has its own RoRo container specifications. These allow containers up to 35 cu yd and stipulate clearances.

Hand-fed compactors

Stand-alone compactors can be fed by staff (putting in bags) and packed into integrated wheeled-ins or 1–2 cu yd containers. Vertical compactors which pack into 3–8 cu yd containers are common for wet waste applications where there is not space for larger compactor containers.

Compacting receptacles

Compacting waste receptacles, which can be used for trash or recycling, can be interior or exterior and are safe for public use. A typical installation in NYC is the exterior Big Belly street receptacles. They are digitally enabled to alert maintenance staff when they require emptying.



Self-contained compactor in loading dock

Balers

Commonly used for cardboard, balers can also be used for metal and plastic recycling (cans and bottles) and plastic film, although each stream should be baled separately to retain the commodity's value. Consideration for an on-site baler includes space and clearance for servicing the machine and space for the bale to be off-loaded, stored and moved to the setout location. This is commonly done with a hand trolley, though can be with a forklift and pallet. Breaking down cardboard and putting into a baler is more labor intensive than putting into a large compactor but less labor intensive than hand bundling. Compaction rates vary but can be up to 8:1 for cardboard and 5:1 for plastic and metal recycling.

Crushers and Shredders

See also food waste pulpers and shredders under [Organic Waste Pretreatment](#).

Glass crushers

These machines are useful for volume reduction for businesses that generate a high volume of glass bottles not returnable for reuse; the compaction ratio is approximately 5:1.

Paper shredders

Used for security purposes, in disposing of sensitive documents, shredders typically remove a large proportion of paper waste from haulers' waste stream as they are serviced by a separate company. Storage must be provided for shredding consoles (locked bins for paper).

2.23 ORGANIC WASTE PRETREATMENT (RESIDENTIAL)²⁰

In residential buildings, options are usually a form of composting or in-sink food waste grinders. While the latter reduce vehicle miles traveled, they can also overtax wastewater treatment plants (WWTP), and whether there is beneficial use of the biosolids depends on the WWTP.

In-sink Food Waste Grinders

- Food waste is mechanically broken down and disposed of through the sewer.
- The purpose is to avoid hauling impacts. Food waste grinders discharge effluent with high levels of total suspended solids (TSS) and biological oxygen demand (BOD). In-sink grinders are not permitted in NYC commercial facilities, although they are in residential buildings. NYC DEP is monitoring their impact on WWTP so rules may change in the future.
- Equipment is very compact and fits under the sink. Organics are washed directly into the sink, maximizing convenience.
- Can process all food waste but vendors suggest that coffee and eggshells can be bad for building plumbing. Non-food items should be kept out of disposals.
- Water and electricity usage is moderate, and water usage varies depending on moisture content of waste.
- Environmental impacts are mixed. In-sink equipment cannot process soiled paper and other material that would otherwise be composted limiting potential for diversion. The pretreatment phase of sewage in a WWTP is expensive and having additional solids go through it adds costs and can overtax the WWTP.

Whether there is beneficial usage of the organic content depends on the WWTP: if it has anaerobic digestion and uses the biogas, or recycles biosolids or whether they end up in landfill. For WWTP that do not have enough capacity and in areas subject to combined sewer overflow events, the effects can be detrimental.²¹

Indoor Bins: Bokashi and Worm Bins

- Bokashi, a Japanese method of composting, involves fermentation through addition of beneficial microbes. Input can include meat, dairy, fish, napkins and organic waste but not large bones and shells. It can be done within an apartment—typically in a five-gallon lidded bin—and should not smell. Vokashi, which offers bokashi compost service in NYC, delivers 5 gal. containers and “beneficial bran” to residences or businesses, and it collects the former once a month. (See [Starrett Lehigh case study](#).)
- Worm bins can be used in apartments, too, but require a greater commitment from residents.

Backyard composting

When there are residents or staff to manage it, composting within a shared terrace, backyard, community garden or rooftop is a good option.

2.24 ORGANIC WASTE PRETREATMENT (COMMERCIAL)

On-site organic pretreatment options are multiple and include mechanical, biological and thermal treatments. Output may be discharged through the sewer system or need transport,

and the composition of solid output varies, typically requiring further treatment before it can be used as fertilizer or compost. Steps to reduce waste should be considered before equipment is purchased. Included below are the common types of organic waste pretreatment, but careful consideration should be given to the issues below as not all equipment types are recommended. For initial recommendations for your building—based on volume of food waste generated—use the [Waste Calculator](#).

Considerations for a Client

- Size: Can this fit into a commercial kitchen (liquifiers, dehydrators and pulpers typically can)?
- Feedstock: Can it take bones, compostables or napkins? Is it tolerant of high-acid or active yeast input such as citrus or bread dough?
- What utilities are required: energy, water, sewer connection, waste hauling? If there’s a sewer connection, are there municipal regulations governing the equipment?
- What’s the capacity of equipment: batch or continuous operation and time from input to output?
- Environmental issues: Regarding energy and water usage, is there beneficial use of the output?

Most equipment falls into the following categories, although some are hybrid systems and new processes and equipment are being developed. Evaluating different pieces of equipment is difficult as many companies’ claims are unverified; output is dependent on feedstock and there is no universal standard for evaluation.²²



Aerobic digester with liquid output to drain (BioHitech pictured)

Aerobic Digesters With Liquid Output/Liquifiers/Food to Drain

- Food waste is broken down aerobically (in the presence of oxygen) by microbes, producing effluent that goes through the sewer. Most systems have built-in shredders.
- The purpose is to improve effluent quality before discharging into a sewer and reduce hauling costs. Food waste grinders discharge effluent with high levels of TSS and BOD. Aerobic digesters reduce these levels considerably. In NYC, in-sink grinders are not permitted in commercial facilities; aerobic digesters are, however, but they must be registered with DSNY. DEP is monitoring their impact on WWTP, so rules may change in the future.²³
- The equipment is relatively compact and can fit into a kitchen, and continuous feeding is okay.
- It doesn't accept napkins or compostables and needs a shredder to accept bones, shells and hard material. There can be issues with high-acid or yeast food waste that adversely affect the biological decomposition process.
- Water usage is higher than other options (and dependent on the water quality of food waste), but electricity usage is low.
- Environmentally mixed: High water usage is a concern. Whether there is beneficial usage of the organic content depends on the WWTP—if it has anaerobic digestion and uses the biogas, or recycles biosolids or whether they end up in landfill. For WWTPs that do not have enough capacity and in areas subject to combined sewer overflow events, the effects can be detrimental. Little is known about the quality of effluent as NYC does not require it to be tested.

Aerobic Digesters With Solid Output/In-Vessel

Accelerated Composting

- Food waste is broken down aerobically by microbes, producing a nutrient rich organic solid that requires some additional curing or possible addition of carbon before it can be used as a “compost.” Some systems have a built-in grinder or shredder, and most use a composting drum.
- The purpose is to create fertilizer in a smaller footprint and less time than traditional in-vessel or outdoor composting.
- The equipment is typically too big for a kitchen. Continuous feeding is normally allowed, and it takes anywhere from 18 hours to 7 days total to process.
- The equipment can accept a low percentage of napkins or compostables and needs a shredder to accept large bones, harder shells and some other hard materials. There can be issues with high-acid or yeast food waste, which adversely affects the biological decomposition process.
- Some use water in the grinding or pulping process, but no water is needed for digestion and electricity usage varies as some apply additional heat and some use only heat generated through digestion. Sewer connections are required only for systems that dewater ground/pulped food waste prior to digestion.
- The equipment is environmentally good as recovers nutrients and produces soil enrichment.



In-vessel accelerated composter (Rocket pictured)



Anaerobic digester (SEaB Energy pictured)

Anaerobic Digesters

- Microbes break down food waste anaerobically—in the absence of oxygen—by producing biogas or methane, some of which powers the process. The excess can be used as gas or converted to electricity through a combined heat and power system. Other outputs include nutrient-rich organic solid/slurry that can be used as liquid fertilizer, dewatered into a solid soil amendment or further processed into compost. If biosolids are dewatered, the process also creates an effluent that can be filtered and reused as graywater.
- The purpose is to make the most usage out of food waste by converting into energy and fertilizer and even back into water.
- Large equipment (typically contained in full or half-shipping containers) typically sited on the building exterior. Continuous feeding is allowed, and processing takes 14 to 28 days.
- Equipment can accept all food waste, paper and compostable bagging but not compostable plastics. Paper and compostable bags do not contribute to energy production, so some vendors discourage their use.
- Water usage is low and can make rather than use electricity. A sewer connection is required.
- They're environmentally very good as they recover energy and nutrients. Cleaned biogas can be used to power a boiler or for cooking gas or be converted directly to electricity and heat in an attached combined heat and power plant.

Dehydrators/Dewaterers

- These use heat and agitation to evaporate—or a centrifuge to remove—the moisture from food waste. The moisture is then collected and disposed of via sewer and the remaining dried pulp—sterile biomass—can be hauled off-site for conversion to compost or fertilizer. Most systems have built-in shredder/grinders.
- The purpose is to reduce the volume and weight of food waste by using heat and or air to evaporate the water, leaving a stable dried substance that doesn't emit odors (as long as it is kept dry) and can be hauled off-site for beneficial use.
- The equipment is compact and can fit into a kitchen; it normally requires batch feeding.
- Equipment can process all food waste, as well as soiled paper, waxed cardboard and napkins. Systems with more industrial grinders can handle a small percentage of bioplastics mixed in with food waste.
- Water usage is low, but electricity usage is high. A sewer connection is required for condensate.
- The results are environmentally mixed: High-energy usage is a concern, as they do retain nutrients and organic matter for positive reuse and doesn't use water.
- Some hybrid dehydrator and aerobic digestion systems, such as Biogreen 360 and GlobalEnviro, combine the benefits of both.



Dewaterer (Rendisk Solus pictured)

Shredders/Pulpers/Grinders

- They reduce volume and waste through mechanical shredding and pressing out of liquid.
- The purpose is to reduce volume and weight to reduce storage and hauling impacts.
- The equipment is compact and can fit into a kitchen; it allows continuous feeding.
- Water and electricity usage are low; a sewer connection is required for effluent removal.
- Equipment can process all food waste, napkins and paper, paper compostables but not bags as can clog the mechanism. Some can handle bioplastic compostables, but it's necessary to check with the vendor as sometimes plastics clog or gum up the mechanism.
- It's environmentally beneficial for reducing vehicle miles in hauling, but the overall impact depends on treatment post-hauling.

Indoor Fins: Bokashi

See [BPS 2.23](#). Bokashi is also well suited to office pantries, as it works well with a drier waste with limited liquids.

(See [Starrett Lehigh case study](#).)



Pulper

Construction & Demolition

Waste Context

The Circular Building, by Arup, is a fully demountable prototype to show how the circular economy can be applied to the built environment. Each component is tagged with digital technology with information to aid reuse, and the data is part of a Building Information Model.



C&D Activities and Waste Stream

To reach zero waste, the city will need to address construction and demolition (C&D) waste, which is defined as discarded building materials, packaging and rubble generated during building and structure construction, renovation and demolition (excluding natural land-clearing and excavation materials such as rock, soil, stone and vegetation).

Nationwide, C&D waste accounts for 25%–45% of the solid waste stream by weight, and it is often contaminated—with paint, adhesives, fasteners—and even toxic. Studies done on New York City indicate a higher percentage of C&D waste, though there’s a lack of reliable data because transfer stations self-report to DSNY. Quarterly reports from 2016 indicate that the city processes an average of 7,500 tons of C&D waste per day.

Chapter 2’s Best Practice Strategies looks at how architects can reduce waste through consideration of waste streams created daily within their buildings. This chapter looks at how architects can consider waste generated during construction of a building and at subsequent demolition phases (for refurbishment or at end of life of the building). This balance is akin to the ways architects can reduce energy requirements—for both the operating energy within a building and the embodied energy within the building itself. For many large commercial buildings, C&D waste is a near daily stream; chances are that at any time, a unit somewhere in the building will be undergoing refurbishment.



C&D waste at a Materials Recovery Facility.

Estimates indicate that of the building materials waste generated, 10%–15% become waste during construction;²⁴ the remaining 85%–90% become waste when that part of the building is demolished or replaced.

Rules and Standards

DSNY Rules

DSNY 16 RCNY §1-10 designates C&D waste—excluding plaster, wall coverings, drywall, roofing shingles and glass windowpanes—generated by construction businesses as recyclable. It also requires that this waste be source-separated from other waste streams.

NYC’s Business Integrity Commission certifies city waste haulers and maintains a comprehensive list of registered haulers approved to remove construction and demolition waste.

LEED v4 Credits

LEED has credits for materials and waste management, including for Construction and Demolition Waste Management Planning and for reaching diversion goals of 50% or 75% of the total C&D material. These targets are by weight, so steel and concrete are substantially more important than gypsum wallboard (GWB), ceiling tile and other light materials. There are also credits for Building Life-Cycle Impact Reduction and Building Product Disclosure and Optimization, which are harder to achieve. These look at related material impacts including life-cycle assessments of energy, water use and the health and environmental impacts of materials. (See [Appendix](#).)

Enterprise Green Communities Criteria with NYC Overlay

EGCC is a nationwide green building criteria list designed for affordable multifamily housing. NYC’s Housing and Preservation Department requires that projects follow it and has an overlay that makes some of the credits mandatory. Credits are available for Recycled Content

of Materials; Regional Materials; Certified, Salvaged and Engineered Wood Products; and Construction Waste Management.

Recycling Certification Institute (RCI)

Substantiation of reported recovery and recycling rates is provided by RCI, which requires independent evaluators to verify the accuracy and reliability of the data. (See [certified facilities](#).)

Building Code Requirements and Green Codes Task Force Proposals

Although there are requirements for safeguards during demolition (BC 3301), there are no diversion requirements and little requirement for recycled content. The Green Code Task Force proposal RC4, which passed, requires 30% content of recycled asphalt by weight (or 10% for heavy-duty asphalt). Proposal RC1 required ceiling tiles, carpeting, new GWB scrap and large-dimension lumber to be sorted on-site and reused or recycled; it also required construction-waste management plans for large projects. Though it did not pass, the proposal formed the background to Carpet Working Group and work by Building Product Ecosystems.

Global Context

Material Shortages

Since 1980, the amount of materials extracted worldwide has doubled. In 2010, it reached close to 72 gross tonnage (GT), and it is projected to reach 100 GT by 2030. The construction sector represents 36% of this total.²⁵ These trends indicate that material shortages in the construction industry will likely increase in the near future.



Office furniture takeback (Steelcase end-of-use program shown)

Takeback Programs

Increasing numbers of manufacturers are offering takeback programs for their products, including office furniture, carpet and ceiling tile. Programs aim to reuse or repurpose products and divert recyclable materials.

Collaborative Consumption

Collaborative consumption slows down material flows and the creation of waste through efficient use of assets. It has three distinct systems:

- Redistribution markets: Unwanted and underused goods are redistributed, through organizations such as BigReuse or AptDeco. For other reuse organizations see [DSNY's DonateNYC's website](#).
- Collaborative lifestyles: Nonproduct assets such as space, skills and money are exchanged and traded in new ways. Two examples, Spacious and Kettlespace, make provisions in restaurants—during closed daytime hours—for freelancers to work.
- Product service systems: In this type of system, the consumer pays to access a product rather than to own it outright. Car2go (car sharing), Citi Bike (bike sharing), Turo (private car sharing), Spinlister (private bike sharing) and Philips, which offers lighting as a service rather than as a product, all reflect this new model.

Technical Changes: Data, Passports, ID Tags

New technologies that allow us to encode materials with information can greatly lower waste creation. This information will be useful for deconstructing a building and repurposing materials. A building can be considered a “material bank,” and if the project was modeled via building information modeling (BIM),²⁶ including material information, the contents of the material bank are easily accessed virtually. There are also low-tech examples of data being connected to materials—for example, members of the Carpet and Rug Institute (CRI), who represent over 95% of the US industry, have agreed to list the material makeup of a carpet on its underside, making the proper recycling method easier to determine. (To date, special equipment has been needed to determine a carpet's composition.)



Pilot pour using concrete containing glass pozzolan, Halletts Point

“Waste is material without information, so by providing material with adequate information, we prevent waste and create value.”

—Thomas Rau, turntoo²⁷

New York City context

Circular Material Loop Initiatives and Organizations

- Building Product Ecosystems (BPE) is working with a multi-disciplinary group to look at promoting circular material loops, with special attention paid to the health issues associated with materials. They are presently looking at GWB recycling and replacing the cement (or flyash) in concrete with local recycled glass pozzolan.
- As part of the development of these guidelines, AIANY worked with Urban Green Council to convene a group of stakeholders to build upon the Green Codes Task Force proposal for carpet recycling.
- Carpetcycle provides demolition services for GWB, carpet and acoustic ceiling tile in commercial projects, in order to divert materials from landfill. Carpetcycle partners with manufacturers of carpet and acoustic ceiling tiles with takeback programs, such as Interface, Shaw, Mohawk and Armstrong.
- Big Reuse has two building material reuse centers in NYC that divert over 2000 tons of building material each year for reuse. Materials accepted include doors, appliances, plumbing fixtures, lumbars, kitchen cabinets, and flooring. Small demolition crews from the centers will remove some items. Additionally, Big Reuse has recently begun a paint reuse pilot project²⁸ to test the feasibility of remixing partially used containers of latex paint into larger batches and then repackaging them.

Landfill Costs

NYC has high landfill costs, meaning that it is economically advantageous for transfer stations to divert many materials.

Construction Site Logistics

Contractors typically collect C&D waste in “minis”: 0.5 cu yd containers, though larger containers – 1 or 2 cu yd and even 20–35 cu yd containers may be used. The hauler usually provides them and takes them to a waste transfer station and/or processing center when full. Some separation of materials may happen on-site, and some recyclers of materials will pick them up directly from the construction site. Space is often tight, and if the specifications do not call for separation, materials are often mixed and brought to a processing center for sorting and transport to recyclers, waste to energy plants, cement kilns and landfills outside the city. Some NYC facilities, such as scrap metal yards and clean fill facilities, accept certain separated streams for reduced costs. While some materials are fairly easy to sort at a processing facility, others—like GWB, carpet and ceiling tile—are damaged and rendered unrecyclable if put in mixed containers.

C&D Waste Composition

The table shows NYC data from a local processing facility²⁹ and indicates that much of the waste that it receives can be recycled, though it is often downcycled. The category “screenings” refers to materials such as GWB and ceiling tiles that break up and are used as alternative daily cover on a landfill, which LEED no longer considers recycling.



Windows at BigReuse



0.5 cu yd ‘minis’
used for bulk waste

Challenges

Space constraints

Space is tight at most NYC construction sites, and staging area is often only available curbside. It takes more planning and coordination to keep recyclables separated on-site.

Labor costs

High labor costs in NYC make it more expensive to recycle materials than elsewhere.

Split between operating and construction costs

A split between responsibility and accounting for capital and operating costs makes it hard for the developer and design team to make the life-cycle argument for selecting durable materials.

Split between owners and tenants

In commercial buildings, tenants are the primary generators of C&D waste during renovation. Building owners need to include the requirements for C&D waste management in leases.

Lack of information and data

It can be difficult for designers or developers to source recycled or previously used materials or components. There is no central online resource/source that allows developers to know what material is available now or will be soon so they can account for it in their development. Also, as there are commonly no quality protocols for recycled materials, their performance is not guaranteed.

Material	% of Stream (by weight)	End Use	
Rock, brick, concrete, tile	22%	Rock & concrete	Aggregate – approved DOT road-base
		Red brick	Landscaping, baseball field clay
		White brick, tile & porcelain	Aggregate – not approved road-base
Wood	25%	Clean dim. lumber (CDL)	Mulch, landscaping
		CDL + glued wood wood	Biomass / alternative fuel
		Non-lead painted wood	RDF
Plastic	3%	LDPE / Film	LDPE / Film
		HDPE / Rigid	Paint buckets, garbage cans, auto parts
		PP	Auto parts, tool cases, industrial plastic
		PVC & Vinyl	Not recyclable - landfill
Paper & Corrugated	2%	Paper and cardboard boxes	
Metal	8%	Ferrous	Re-used as scrap metal
		Non-Ferrous	Re-used as scrap metal
Screenings	35%	Alternative Daily Cover	
Landfill	5%	Treated wood, PVC, nylon tarps, roofing material, insulation	

Data from a NYC C&D recycling facility showing end use of materials

Opportunities

Demolition permit process

For projects requiring a demolition permit, there is a window of opportunity to salvage furniture and finish materials—carpet, for one—before the demo process starts. NYC requires asbestos testing before the demolition can begin. In Denmark, the requirement for more extensive hazardous material testing allows a longer stretch of time for salvage.

Leadership from city agencies

City agencies can help promote change through practices in their new buildings. For instance, the Department of Design and Construction (DDC) is using some of pozzolan concrete for sidewalks in its projects.

Bonds/deposits

In San Jose, California, all projects requiring a building permit also need to make a Construction and Demolition Diversion Deposit proportional to the project's size. To get the deposit refunded, developers have to demonstrate they've recovered a baseline of C&D waste.

Fiscal drivers

Other countries—the UK, for example—have used incentives like landfill taxes and levies on virgin aggregate to reduce the amount of C&D waste sent to landfill.

Construction & Demolition Waste Best Practice Strategies

The Living's Hy-Fi structure for MOMA PS1 gallery is made of bricks fabricated from ecovative—a product grown from agricultural waste and mycelium. The bricks require minimal energy to make and both the steel forms and the bricks can be recycled, in technical and organic circular loops.



Strategies to reduce waste during construction fall into three broad categories:

Designing for Material Optimization

Reduce the amount of materials within the fabric of the building, as well as the waste produced during construction. Design for deconstruction of materials and components at the end of their useful life.

Material Selection

Promote a circular economy by reusing materials and components and specifying materials with recycled content.

Waste Management Planning On-Site

Ensure that procedures on the construction site facilitate waste segregation and recycling.

Planning for reduced C&D waste must happen at a project's start and be part of an integrated design approach.³⁰ Considerations per phase include:

Pre-Design Phases

- Set goals for waste reduction and decide if design for deconstruction and flexibility principles can be used.
- Survey the existing site to see if reuse of building components or adaptive reuse of the building is possible.
- Programming: Can space be made smaller through a more efficient use of assets?
- Methods: Can design be BIM to include material information, with life-cycle analysis embedded?

Schematic Design

- Hold a collaborative workshop at the schematic design phase, for creative solutions for material optimization and waste reduction.
- Consider constructing building components and modules off-site.

Design Development & Construction Documents

- Coordinate dimensions between structural, planning grids and floor-to-floor heights and modular materials. Standardize similar elements of the building for repeatability.
- Use BIM for three-dimensional coordination and material information.
- Write specifications that detail C&D waste diversion requirements and on-site separation and minimum requirements for recycled content; also, allow for the use of offcuts and reclaimed products and materials.

Material Optimization Strategies

2.25 MAXIMIZE ASSET UTILIZATION THROUGH PROGRAMMING

Program to make the most use of an asset

Providing flexible spaces that can perform multiple functions, as in NYC's School Construction Authority's gymatoriums which maximize a space's use by serving as both gym and auditorium. This can also happen at a neighborhood scale—e.g., The Center for an Urban Future's report *Reenvisioning Branch Libraries* explored the variety of functions libraries could serve as they maximize the utilization of space.³¹

Design to Increase the Usage of Spaces and Equipment Within a Building

Smart planning can reduce built area, furniture and equipment to optimize the use of every space and piece of equipment. Consider whether spaces can be multifunctional or flexible so they'll be used consistently all day long. Studies show that the average office is used 35%–40% of working hours. Hot-desking, in which each employee is not assigned a desk, allows for a smaller space; it also provides a variety of workspaces and benefits employees who work remotely.³²

2.26 DESIGN TO OPTIMIZE MATERIAL USAGE

Design can make the most of materials that become the physical fabric of the building. This decision should be balanced with longevity, flexibility and other life-cycle considerations. Strategies include:



Polished concrete floor and exposed ceiling reduces finish materials.

- Design efficient structural systems that use less material for the same performance—such as a braced steel frame instead of a moment frame, or a material-efficient foundation system.
- Rationalize MEP layouts to reduce material and energy usage from friction within ducts and pipes.
- Choose finish materials that serve multiple functions—such as pin board and acoustic treatments, or use structural materials that do not require applied finishes.

2.27 DESIGN TO REDUCE WASTE GENERATED DURING CONSTRUCTION

Considering the construction process ahead of time aids in determining where waste is created; engage the contractor early. Design to lower the number of material offcuts.³³

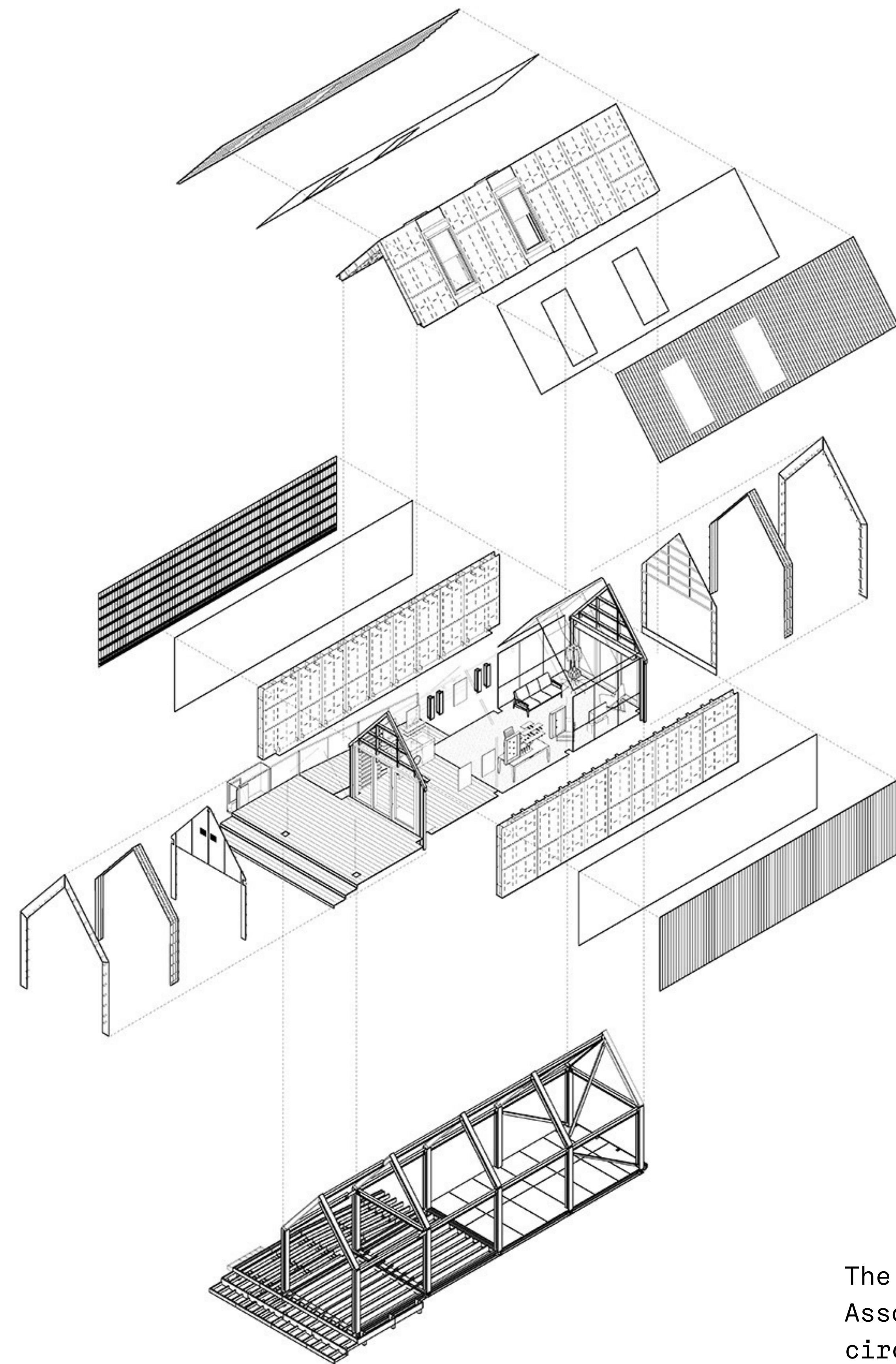

The circular building by Arup Associates was designed to circular economy principles.

Coordinate Dimensions and Minimize Finish Types

- To minimize cutting, coordinate dimensions between modular materials such as panels or tiles and finish areas.
- Reduce number of different types of finish materials, such as GWB and tile.

Design for Off-Site Construction

Off-site construction has been shown to create less waste by reducing errors and rework. It also reduces offcuts and allows for their reuse and recycling.

Use Building Information Modeling (BIM)

BIM and/or three-dimensional modeling of all building systems allow for virtual coordination, thereby minimizing on-site construction errors.

2.28 DESIGN FOR DECONSTRUCTION AT THE END OF LIFE OF A BUILDING COMPONENT

The many layers of a building have different life-spans. Shearing Layers, a concept coined by British architect Frank Duffy, lists them in order of decreasing life-span: Site, Structure, Skin, Services, Space Plan (interior partitions, finishes) and Stuff (furniture).³⁴ Design for “slippage” so removal of short life-span layers can occur without disturbing longer life-span layers. Consider an end-of-life destination for each layer.

Design for Easy Refurbishment of Isolated Materials

Design for replacement ease at the smallest level. For instance, selecting floating carpet tiles that adhere with tabs ensures that damaged tiles can be individually replaced; some carpet manufacturers blend in tiles from another dye lot so attic stock won't be required.

Design for Deconstruction and Disassembly

For ease of separation and deconstruction, fix components together by reversible means. Consider mechanical fixings; avoid gluing and composite materials. Consider using a type of mortar that allows bricks and blocks to be easily dismantled.

Provide Material Information: Material Passports

Consider providing information about building materials that will allow for easier reuse later. The information may be available in a BIM data model and can also be physically attached to the materials.

Consider Suppliers Willing to Take Back Materials at End of Life

When possible, buy a service as opposed to a product. Philips, for one, doesn't just provide individual light fixtures—it provides lighting as a service. This gives a manufacturer incentive to offer long-lasting, easily maintained products and puts the onus for removal on the service provider.

Material Selection Strategies

2.29 REUSE EXISTING MATERIALS—AND BUILDINGS—ON-SITE

On the initial site visit, survey all materials and structures, if any, that are available for reuse. Then aim to reuse them at their highest capacity.

2.30 USE RECLAIMED COMPONENTS AND MATERIALS

While reclaimed components and materials offer great savings, they do present challenges, including a lack of guaranteed performance

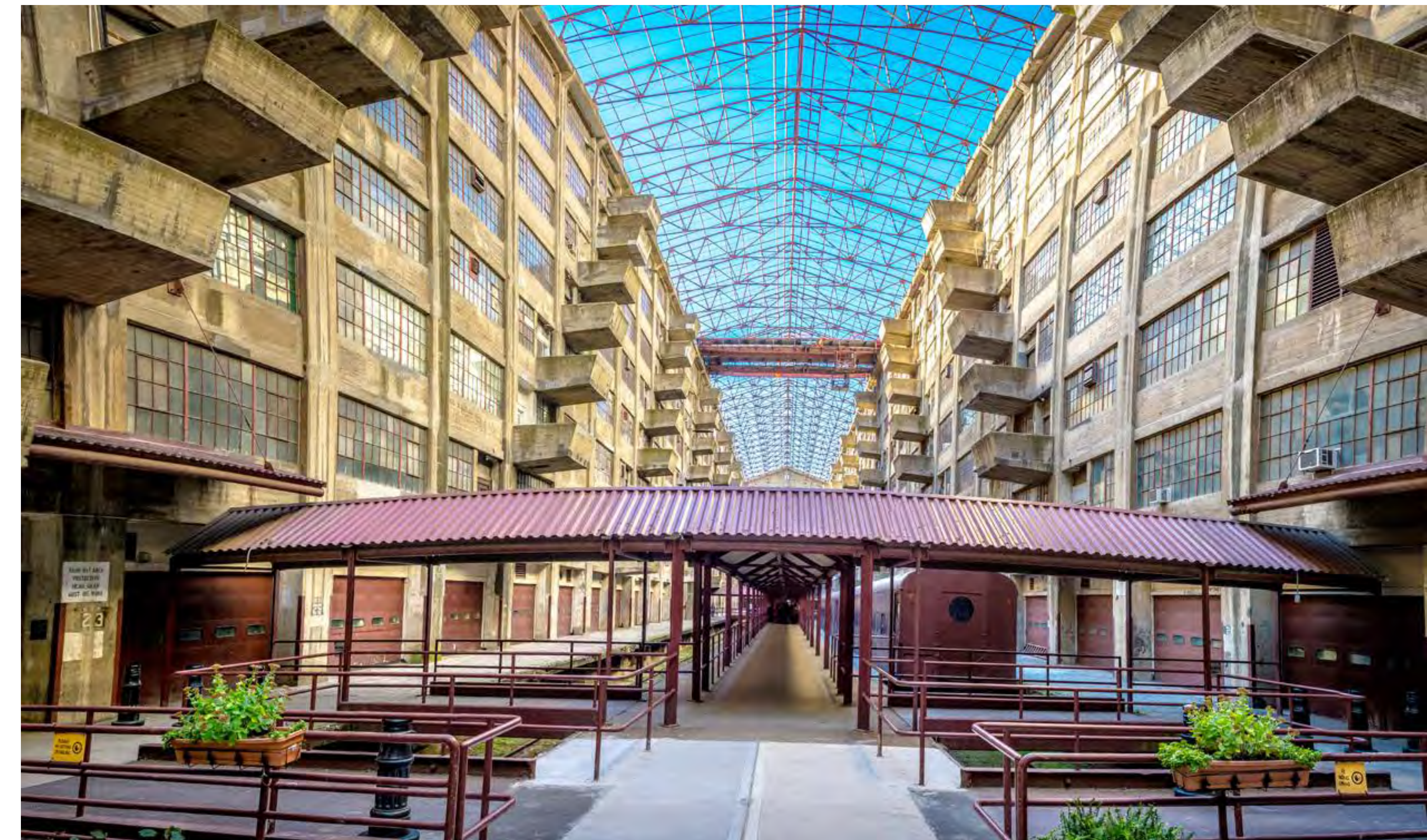

Lighting in Schiphol Airport is provided by Philips as a service; Atrium of EDC's Brooklyn Army Terminal industrial campus. (Adaptive reuse of 4.1 million sq ft building)



Reclaimed raised floor system and wood paneling used in the Audubon offices by FXFOWLE

and difficulty in sourcing. Reclaimed finish materials that offer good performance and aesthetics, such as old-growth lumber salvaged from barns, have substantially entered the market.

- Consider reclaimed components like raised floors, kitchens, furniture systems, doors and carpet.
- Consider choosing reclaimed materials—such as bricks and lumber—especially if they’re local.
- Reuse excavation material and balance cut and fill on-site.
- Write specifications allowing the contractor to substitute approved reclaimed components and materials.



GWB scraps separated for recycling in 30 cu yd containers on a large construction site

2.31 SPECIFY RECYCLABLE MATERIALS WITH HIGH RECYCLED CONTENT

- Consider materials with high recycled content that can themselves be recycled at the end of life, preferably in a continuous circular loop without downcycling.
- Consider locally sourcing recycled materials, such as glass pozzolan, which can replace cement in concrete.
- Consider Cradle to Cradle–certified products.
- Explore the health impacts, performance and product durability materials options.

Waste Management Strategies

2.32 REQUIRE A CONSTRUCTION WASTE MANAGEMENT PLAN

Write specifications to require a construction waste management plan that covers on-site storage and logistics and sets diversion goals. Require that some material—like furniture and carpet—be removed before the demo permit is issued.

- Consider how work sequences affect the generation of construction waste. Whenever possible, engage the contractor early to discuss measures to reduce waste generation.
- Consider imposing a financial impact on the contractor, such as construction bonds, if CWM diversion goals are not met.

2.33 REDUCE SURPLUS MATERIAL

Specify takeback for surplus materials, and just-in-time purchasing to minimize overordering.

2.34 SEPARATE CONSTRUCTION WASTE ON-SITE

- Specify on-site practices to separate easily damaged streams such as GWB, ceiling tile and carpet.
- Consider instituting on-site practices for reducing packaging and ongoing waste generation by workers.



Salvaged bricks are separated for reuse

Building Design

Case Studies

Interior of Etsy Headquarters
in NYC, a zero waste certified facility.
See [case study](#).



Clichy-Batignolles, Paris

Type

Residential Typology 1: Central location

Best Practice Strategies

- 2.08 Provide equal convenience disposal
- 3.03 Provide a system of pneumatic tubes connecting buildings to a central terminal

Summary

Gravity chutes are rare in Paris, as are waste rooms on residential floors. Instead, residents bring discards to bins in a waste room or courtyard at street level, even in brand-new developments. Clichy-Batignolles is a new eco-district in the 17th arrondissement with 3,400 apartments— 50 percent of which are social housing— surrounding a 25-acre park over a restructured rail yard.³⁵ Macrobloc, built in 2015, is a ten-story mixed-use building of 107 units divided into three cores designed by Maast Architectes, Suzelbrout and Toa Architectes, respectively. The ground-floor waste rooms are accessed directly from the lobbies. To economize on space, residents in the middle core share a waste room with one of the other two.³⁶ Inside, there are bins for the four streams: single-stream recycling, refuse, glass and cardboard/bulk waste. Waste bins for mixed recycling and refuse are actually inlets connected to a pneumatic network running one floor below, serving all the buildings in the eco-district. (The pneumatic network is the first in Paris proper and one of several recent installations in the region.) Glass and cardboard are collected in wheeled bins and removed manually from the waste room.



Top to bottom: Clichy-Batignolles eco-district; 153 bis rue Cardinet with pneumatic inlets for residents and daycare visible through facade

Franklin Azzi Architectes literally put the waste inlets at 153 bis rue Cardinet for the 66 residential units and a daycare center on display by locating them in an exterior forecourt between a glass facade and the lobby. Clichy-Batignolles' pneumatic system is designed with room to add a third organics inlet in the future.

Challenges

Inlet locations within waste rooms must be coordinated with the installation of the pneumatic network below.

When residents drop folded cardboard into inlets, it opens up like an umbrella and gets stuck. These blockages are actually easy to remove, but the pneumatic collection cycle comes to a stop until a tech visits the location, reducing the efficiency of the system.³⁷

Applicability to NYC

New York City could pilot central waste rooms adjacent to building lobbies to provide convenient access to all streams for residents as they leave the building.

Whether or not a pneumatic system is connected to the chutes, separating waste storage, particularly for organics and refuse streams, could reduce space requirements and nuisances on the ground floor.



153 bis rue Cardinet pneumatic inlets for residents and daycare

StuyTown, NYC

Type

- Residential Typology 3: Corridor Chute with Central Recycling
- Truck Collection Typology 4: 20–40 cu yd (RoRo) Containers

Best Practice Strategies

- 2.04 Plan for collection
- 2.05 Consider staff procedures
- 2.10 Provide clear visual cues and signage
- 2.11 Provide opportunities for feedback
- 2.12 Develop awareness and education programs
- 2.13 Design for occupancy
- 2.15 Provide shared assets and services
- 2.21 Volume reduction equipment
- 3.02 Provide a central collection facility with multiple loading docks shared between buildings

Summary

Stuyvesant Town–Peter Cooper Village, collectively known as StuyTown, is a development built in the 1940s by Metropolitan Life Insurance company for returning World War II veterans. Covering 80 acres on Manhattan’s east side with 110 buildings (defined as separate entrances and cores), it features 11,250 rental apartments housing approximately 30,000 people.

To date, StuyTown is the largest housing development participating in DSNY’s curbside organics pilot. Each building has compost bins on the ground floor, which are emptied three times a week; collecting over

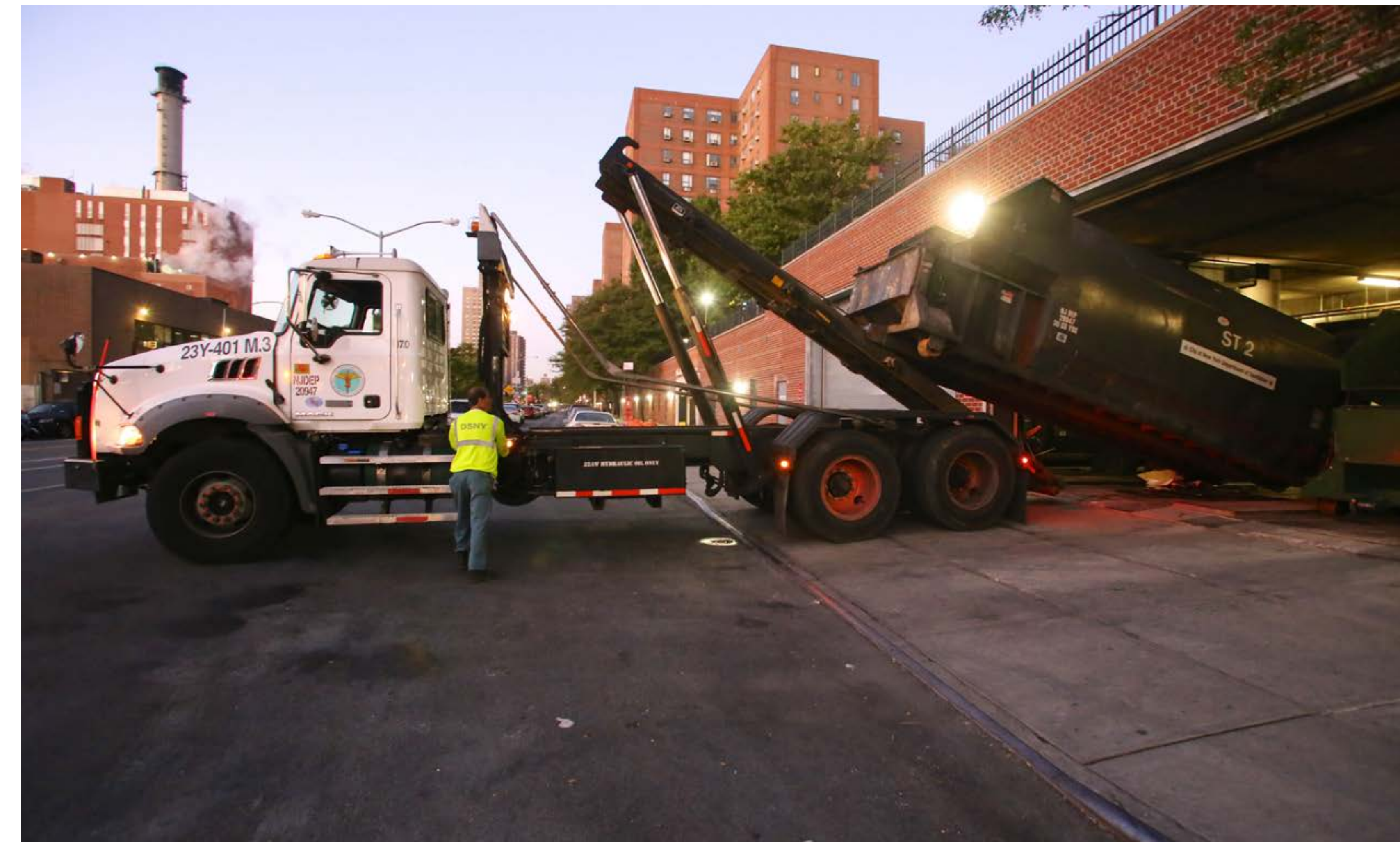

Waste collected in box trucks and consolidated at central facility for collection by DSNY roll on truck

five tons of compost per week. Although this is a substantial amount, calculations based on average waste generation for NYC indicate that this is capturing about 20 percent of the organic material in the waste stream.

After receiving complaints about odors from the brown bins, the StuyTown staff noticed that some residents were having problems closing the catches on the bins. Rather than end the program, the issue was discussed in a weekly staff meeting. StuyTown management uses these meetings to encourage staff from all departments to identify problems and propose solutions. A porter suggested a magnetic catch as a way to ensure bins are kept closed, and a prototype was developed. After successful testing by residents, all the StuyTown compost bins were retrofitted, replacing the latches with magnetic closers. Another topic is the increasing amount of cardboard that fill up the recycling areas, especially when tenants do not break the boxes down as they should. A porter is setting up a test station in the recycling area to help tenants break down cardboard boxes.

In each building, there is a trash chute beside the elevator on every floor and a recycling center on the ground floor or basement. StuyTown is looking to see if this setup, in which the trash chute is more convenient than the organics bins, leads to lower organics diversion. They are working with waste and composting consultants to study whether placing a small 13-gallon organics bin alongside the chute door leads to higher organics diversion. They are also studying whether additional communication with tenants and the provision of kitchen caddies with compostable bags increases the quantity and quality of material collected.

Waste is never piled on the curb on the Stuyvesant Town half of the property. Rather, porters wheel out tilt trucks full of bags of trash to a box truck, which drives it to the central waste facility. The two 30-cubic-yard compactor containers for trash and paper, as well as an open-top container of the same size for recycling (metal, plastic and glass), fill up daily and are collected by DSNY on a roll-on/roll-off truck.



Station for breaking down cardboard and organics bin retrofit with magnet closure

StuyTown is constantly evaluating and improving its waste management practices, aiming to reduce waste and divert more of it. It participates in e-waste and textile programs and is planning to conduct a waste audit to see how much more waste could be diverted—and to give feedback to residents.

Challenges

The buildings are set up to prioritize trash over recycling and organic streams. Although the organics study is testing a small 13-gallon organics bin adjacent to the chute, there is not enough space for all diverted streams to be collected there.

Neither is there space enough to store bulk waste for reuse; it is currently taken to a storage room and broken up. They are looking at ways to increase donation possibilities, beyond the annual StuyTown flea market.

Among StuyTown's diverse population are many students. Their high turnover rate, along with the high number of languages spoken, means that communication is a constant challenge.

The central facility is not large enough to manage the waste from Peter Cooper Village. For that reason, its 21 buildings are staged on the curb for collection by DSNY trucks.



Chute door access behind a door alongside elevator;
Central recycling area between lobby and laundry

The Solaire, NYC

Type

Residential Typology 4: Trash room with Chute and Bins

Best Practice Strategies

- 2.01 Determine waste streams and quantities
- 2.02 Plan a route
- 2.03 Design storage space
- 2.04 Plan for collection
- 2.05 Consider staff procedures
- 2.08 Provide equal convenience disposal
- 2.10 Provide clear visual cues and signage
- 2.12 Develop awareness and education programs
- 2.13 Design for occupancy
- 2.15 Provide shared assets and services
- 2.21 Volume Reduction Equipment

Summary

The Solaire is a 27-story, 293-unit luxury rental building in Battery Park City, designed by Cesar Pelli and Associate. Completed in 2003, it was the first LEED-certified residential high-rise in the United States. Its amenities include a gym, playrooms, a rooftop garden, a car-sharing program, and an apartment cleaning service.



Above:
Entry of The Solaire,
with building integrated
solar panels in canopy
and facade above

Left: Waste room with trash
chute door; bins for compost,
glass, metal, plastic and paper;
and collection of batteries,
sharp objects and hangers.

The Solaire is also one of the city’s first buildings to collect organics in equal convenience locations. Each floor has a waste room with a trash chute and separate bins for metal, plastic, glass and paper. The rooms are serviced several times a day, with recycling and organics removed as required. The concierge offers dry-cleaning services and collects hangers—from rods in the waste rooms—for the dry cleaner to reuse. Besides reducing waste, isolating the hangers prevents them from puncturing trash bags and blocking chutes. Batteries are collected in every recycling room as well. Central collections of electronics (via ecycleNYC) and textiles (from the refashionNYC and Wearable Collections programs) are also provided within the building.

Building management incentivizes recycling with regular building-wide competitions and DSNY/GrowNYC demonstration sessions. Tenants use the organics caddy they are given to collect organic kitchen waste, which they empty into the appropriate bin in their floor’s waste room. Through the online communication system BuildingLink, the Solaire shares information with tenants on recycling and organics collection.

Building manager Michael Gubbins tracks material flows, and in 2016, he recorded 68,000 cardboard boxes in all, a substantial rise over previous years. Through regular sampling of recycling and trash bags, building staff check how well residents are recycling and, instead of levying fines for violations, takes photos to share as teaching tools. Most renters say they chose the Solaire because of its commitment to sustainability, and pay rents up to 10% higher.

Small vehicles transport the bagged trash from the compactor room to a shared 35 cu yd compactor container around the corner (see [Battery Park case study](#)).

Challenge

The bagged recyclables are piled on the sidewalk for curbside collection. Because the bags tend to blow around, building staff erect temporary enclosures to rein them in.



Cardboard and MPG storage in cellar; Storage of cart used to transport trash to shared compactor container

Strivers Gardens, NYC

Type

Residential Typology 4: Trash room with Chute and Bins

Best Practice Strategies

- 2.02 Plan a route
- 2.03 Design storage space
- 2.04 Plan for collection
- 2.05 Consider staff procedures
- 2.10 Provide clear visual cues and signage
- 2.12 Develop awareness and education programs
- 2.13 Design for occupancy
- 2.15 Provide shared equipment and services

Summary

Strivers Gardens, completed in 2005 by Davis Brody Bond LLP, is a full-service 170-unit condominium in Harlem. Comprising one 12-story building with another 7 stories above a garage, shared amenities include a laundry room, gym, lounge, party room and landscaped courtyard.

Building manager Martin Robertson uses Strivers Gardens' online communication system, Building Link, to encourage everyone in the building to play a part in proper waste disposal. Residents are asked to bring cardboard bigger than a shoebox to the basement (cardboard boxes would quickly fill up the tiny waste rooms). Because management receives all packages coming in, it can also identify improperly discarded packaging.

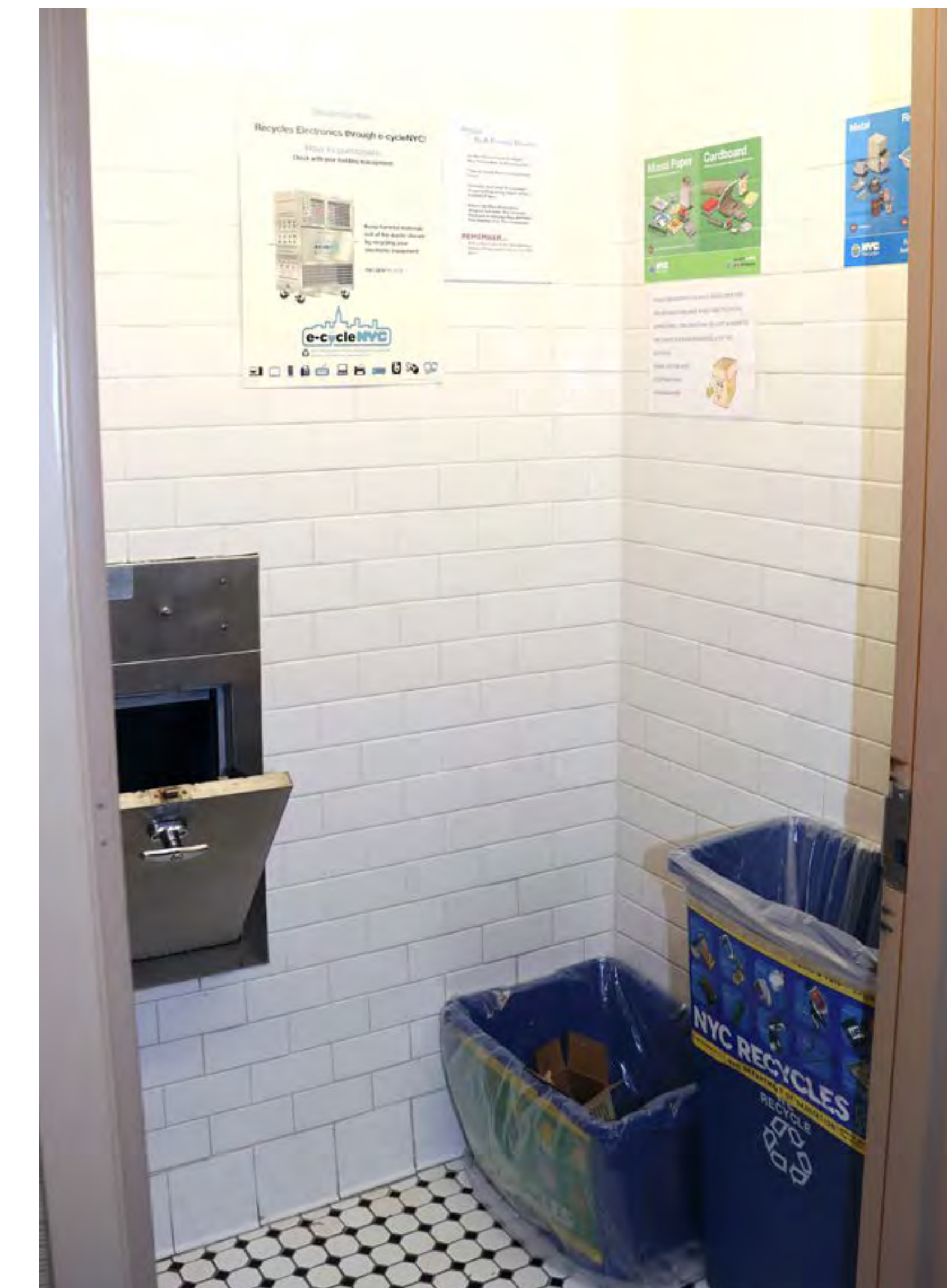

Clockwise from top left: Organics caddy valet service; small waste rooms with trash chute and recycling bins; 'sausage' trash bags with staff initials

Residents are notified and eventually charged a service fee if such habits continue. Bags set out for DSNY pick up must weigh less than 50 lb. Staff members are required to label each bag they handle with their name. If a bag is too heavy, Robertson asks DSNY to leave it so he can address the issue directly with the staff member. Clear printed signs and labeled shelves keep the compactor room tidy and facilitate frequent cleanings. The compactor room is kept pristine, in keeping with Robertson's philosophy that a trash room doesn't have to smell like trash.

Textile collection bins are conveniently located in the laundry room of each building alongside recycling bins for detergent containers. Two organics bins are provided in the basement-level garage, near the bike racks. To absorb humidity and reduce odor, newspaper (diverted from recycling) is available for residents to add to the bin. Separating organics has allowed a reduction in frequency of chute cleanings, saving the building money. To encourage organics participation, management offered the first ten residents to sign up a free stainless-steel kitchen caddy with a carbon filter. Residents can even opt for valet service; if they do, they can leave their full organics caddy with the concierge and collect it clean and empty later. (Staff notice that residents will often ask about participating when they see neighbors bringing caddies to the front desk.)

Residents send trash down the chute—in a small waste room on each floor—and leave recycling in bins next to the chute door. Despite servicing the waste rooms at least twice a day to remove recycling, Robertson would not choose to add organics bins in those rooms. Because they are unventilated, he anticipates that issues of odor and cleanliness would arise.

Challenges

Robertson reports that fighting complacency is a constant challenge. He is always looking to improve upon his systems, further educate staff and residents, and simplify the process for ease of use, particularly for the individual in a hurry.

Recyclables and trash are stored at cellar level. The original building design included a dedicated lift to bring material from the storage area directly to the curb. The service access was eliminated in favor of ground-floor retail, and staff must push heavy carts up the steep parking garage ramp to the street. The Board of Managers recently purchased a motorized pushcart, which has made it easier to move material to the curb.



Staff pushing trash from cellar up parking garage ramp to street

Grand Millennium, NYC

Type

Residential Typology 5: Single Chute with Sorter

Best Practice Strategies

- 2.02 Plan a route
- 2.04 Plan for collection
- 2.05 Consider staff procedures
- 2.08 Provide equal convenience disposal
- 2.10 Provide clear visual cues and signage
- 2.13 Design for occupancy
- 2.21 Volume reduction equipment

Summary

The Grand Millennium, designed by Gary Handel & Associates in 1996, is a 32-story mixed-use luxury building with 300 residential units on Manhattan's Upper West Side.

The Grand Millennium has a bisorter and turntable system (see [Chute Options](#)). Residents use the control panel alongside the chute door to choose MGP, trash or paper which travel through the same chute. A bisorter in the cellar, at the chute's base, sends the trash into a vertical compactor and the recyclable streams into a six-bin turntable system. (Currently three bins are used for MGP and three for paper.) Cardboard, textiles, e-waste and hangers are left in the chute access room for building staff to bring to the appropriate bins in the central storage area on the ground-floor. E-cycle and textile bins, located in service areas, are used exclusively by staff.



Above:
Exterior of building

Left:
View from loading area
through service elevator
to recycling storage
area beyond.

The building's service spaces are well designed for the flow of waste materials. A service elevator opens directly onto the chute access room, allowing for easy removal of additional waste streams. Staff move bagged waste in tilt trucks through the cellar and into a separate service elevator (shared with retail tenants and an extended-stay hotel) that opens directly onto a shared street-level loading area. Contractors also use the service area for C&D waste as residents frequently renovate.

After the ZWDG team visited, building manager Shef Koci proposed organics collection to the board. With board approval, the manufacturer is reprogramming the chute to add the organics stream for two of the turntable bins. If implemented, this could be the first chute-based organics collection in the city.

Challenges

Compared to a conventional chute, the sorter system requires frequent maintenance. A replacement turntable unit was purchased a few years ago. It now tracks which floor the waste comes from which is useful to find important items that residents have mistakenly discarded.

When the Grand Millennium first opened, clothes hangers became entangled at the chute's base so often, the first system had to be replaced. The problem was solved with a frame for stacking hangers, which was placed in chute access rooms.



Above:
Waste room with chute door,
sorter control panel and
service elevator access



Left:
The bi-sorter directs
trash to the compactor
and recyclables to bins
on a turntable.

Avalon Fort Greene, NYC

Type

Residential typology 6: Trash room with multiple chutes

Best Practice Strategies

- 2.02 Plan a route
- 2.03 Design storage space
- 2.04 Plan for collection
- 2.05 Consider staff procedures
- 2.08 Provide equal convenience disposal
- 2.10 Provide clear visual cues and signage
- 2.13 Design for occupancy
- 2.15 Provide shared assets and services
- 2.21 Volume reduction equipment

Summary

Avalon Fort Greene, designed by Perkins Eastman Architects and completed in 2010, is one of many new high-rises in downtown Brooklyn. This 41-story luxury rental building is unusual, though, in that the developer and property management company Avalonbay Communities forgoes DSNY collection, opting instead to pay a private hauler to remove waste from the 636-unit building.

The building has a highly efficient waste route: Two vertical chutes—one for trash, one for single-stream recycling—convey material directly into 2 cu yd containers in a ground-floor waste room. (Under current rules, DSNY collection requires paper be separated from the MGP stream,



Trash and recycling chutes connect to compactors and 2 cu yd containers which are wheeled to the loading area and emptied into a rear end loader truck.

either by adding a third chute or by collecting the third stream from bins in each waste room.) Vertical compactors attached to each chute compact both streams as they enter the containers, which are stored in the room before being wheeled to an adjacent loading room on a side street.

Residents drop trash and recycling in the chutes and leave catalogs and magazines on the waste room floor for building staff to collect. Residents bring cardboard to hampers and textiles to a refashionNYC bin on the ground floor, adjacent to the loading area. Residents bring e-waste to a bin in the loading room, or if items are large, they arrange for staff to come to the apartment. Avalon Fort Greene is not participating in the DSNY organics pilot, but Avalonbay is considering piloting organics collection in another building.

For most of its residential buildings, Avalonbay uses private haulers because they collect 2 cu yd containers. The efficiency of connecting chutes directly to containers that are wheeled out for collection instead of storing and staging bagged waste means that one less porter is needed per building. The savings is comparable to the costs for the hauler service and containers save staff from handling hundreds of bags, some of which contain broken glass. Avalon Fort Greene needs sixteen 2 cu yd containers for storing waste between biweekly collections.

Challenges

Waste rooms on each floor double as service-elevator vestibules. With this arrangement, if bulk materials like cardboard fill the waste room staff cannot exit the service elevator. The management team resolved the issue by requiring residents to bring their cardboard to the service area.

While staging waste for collection in wheeled containers is not physically demanding, two people are needed to maneuver them. The whole process, which takes about three hours and 3-4 staff (two moving containers inside and one or two helping the truck driver empty into the truck), occurs twice a week.

One of Avalon Fort Greene's chutes was installed so that it connected to the container at an angle, and material tended to lodge there. A new insert expanding the bottom of the chute eliminated the problem.

Toronto 3Rs Ambassador Program

Type

Community involvement

Best Practice Strategies

- 2.12 Develop education and awareness programs
- 3.09 Incorporate community into collection operations

Summary

New York and Toronto have a lot in common, including the complexity of reducing waste generated in multifamily buildings. Almost half of Torontonians live in apartments, and this group recycles and composts in significantly lower numbers than those in single-family homes.

Communication is particularly challenging because a third of residents are immigrants and numerous languages are spoken. In 2009, Toronto launched a program inviting interested residents of multifamily buildings to become 3Rs (Reuse, reduce, recycle) ambassadors.³⁸

The city reached out to the public directly, sending letters to every apartment as well as resident recruitment cards to 3,000 property owners.

Interested residents and property managers attend mandatory training sessions, receive access to waste management services staff, invitations to events, ongoing training and volunteer credit. There are currently

370 trained ambassadors in the city.³⁹ Buildings with ambassadors report an average savings of 15% on their waste bills (Toronto initiated a save as you throw program in 2008), and waste management staff report anecdotally of reduced contamination in ambassador buildings.⁴⁰



Lobby display for resident education

A Cascadia study cited lessons learned: the importance of initial training sessions, coordination with property managers (residents are urged to get buy-in and support from management from the start), time spent (ten hours a month is suggested) and ongoing training and communication. Eventually, the city hopes to have at least one ambassador in every multifamily building.

Seattle and Boulder have similar programs. In New Orleans and several California cities, the nonprofit Global Green runs an “eco-ambassadors” sustainability programs, which although not solely focused on waste share many features. Global Green has found that in addition to training,

official city-led programs and programs that train participants in pairs or groups achieve the greatest success.⁴¹

In 2016, drawing on the strength of the 3Rs program, Toronto launched the Mayor's Towering Challenge. The yearlong program provided an opportunity for buildings to work directly with sanitation staff to take advantage of existing initiatives and respond to their own unique conditions to develop their own. Buildings track their progress and compete for recognition and prizes. Nearly 150 buildings representing 22,000 apartments registered for the program. Case studies of the winning buildings are published on Toronto's sanitation service website.⁴²

Challenges

Despite Toronto's efforts to recruit young people, most of the ambassadors skew older and are often retired.⁴³

Volunteers tend to burn out when they take on too much or fail to achieve results they hoped for. Toronto's program manager has found it is helpful to expand "success measures" to include the number of people engaged and reduced contamination rather than focusing solely on diversion rate.⁴⁴

Applicability to New York City

New York has its own Environmental Ambassadors program for New York City Housing Authority residents.⁴⁵ The Mayor's Office of Sustainability has organized the Mayor's Zero Waste Challenge for businesses and institutions.⁴⁶ DSNY also offers support and training sessions for residential building managers.

A citywide program for private residential buildings could help property managers and residents join forces to take advantage of opportunities to reduce waste and improve recycling in all multifamily buildings. Case studies resulting from a residential waste challenge could bring an added human dimension to the DSNY communications.



Eco-ambassador food waste education in Santa Monica run by Global Green

Park Slope Food Coop, NYC

Type

Commercial Typology 1: Stairs or Ramp to Sidewalk

Best Practice Strategies

- 2.06 Plan for takeback of delivery materials
- 2.10 Provide clear visual cues and signage
- 2.14 Design for occupancy
- 2.16 Reduce material consumption
- 2.17 Reduce food waste generation
- 2.18 Facilitate donation and reuse
- 2.22 Volume reduction equipment

Summary

The Park Slope Food Coop is a consumer-owned grocery store selling a million dollars worth of groceries a week—more than double the per sq ft sales of an average Whole Foods. Yet it occupies a surprisingly small space. Merchandise is sold from a 6,000 sq ft shopping floor; on the second floor is a combined 14,000 sq ft of office and community space; and there's a receiving area in the basement. Members must work in order to shop. Most of the labor for day-to-day operations, from stocking shelves and cashiering to washing floors and emptying trash, is done by the more than 17,000 members, who are managed by 75 paid staff.

Over the years, the co-op has instituted a number of initiatives to reduce waste. Much of the food, from produce to dry goods, is purchased in bulk quantity rather than individual packages. Customers buying bulk goods



Top to bottom: The coop's two adjoining buildings, waste is stored in container within sidewalk enclosure; Unpackaged produce is displayed in shallow trays

from the 100 self-service bins are encouraged to use their own reusable bags, although plastic bags are also provided. Instead of disposable paper or plastic shopping bags, cardboard boxes are made available for reuse near the checkout. To minimize spoilage, produce is displayed in shallow bins and constantly restocked. Nonsalable food that is still good to eat is donated to seven different food pantries; spoiled produce and other organic waste goes into a compost bin and is retrieved by local composters. Pet food in damaged packages is brought to an animal rescue organization. Wood pallets as well as plastic and wooden crates are returned to farmers and suppliers.

Cardboard boxes and plastic film are baled for collection. All recyclable materials are staged in a narrow alleyway behind the store. As there's no dedicated loading area within the store, refuse is kept in a 2 cu yd container behind a screened enclosure on the sidewalk. A special committee collects water filters, toothpaste tubes, cereal bags, energy bar wrappers—and other packaging NYC doesn't recycle—on a bimonthly basis, through the TerraCycle program. In the office, printers are stocked with scrap paper.

Challenges

Contamination occurs when members emptying garbage cans are not well versed in proper recycling procedure.

At times, members stocking produce and sorting nonsalable items into bins for donation and compost make classification errors. Clear signage and staff oversight help reduce such incidences.



Cardboard boxes for shoppers use, cardboard baler, bulk dry goods, collection of nonsalable produce for donation or compost

640 Fifth Avenue, NYC

Type

Commercial Typology 2: Elevator to Sidewalk

Best Practice Strategies

- 2.01 Determine waste streams and quantities
- 2.02 Plan a route
- 2.05 Consider staff procedures
- 2.07 Considerations for multi-tenant buildings
- 2.09 Provide equal convenience disposal
- 2.10 Provide clear visual cues and signage
- 2.12 Develop awareness & education programs
- 2.14 Design for occupancy
- 2.18 Facilitate donation and reuse

Summary

Waste from buildings with limited indoor storage is usually staged for street pickup every night. Without containerization, the waste can attract pests and offend neighbors. To avoid such problems, Vornado Realty Trust designed an efficient system for moving the waste generated by the office tenants at 640 Fifth Avenue, a 22-story, 327,000 sq ft tower.

In some offices, waste is no longer tossed into a small trash bin under each desk. Instead, tenant employees carry their waste into common areas to separate wet trash; paper; and MPG into their respective containers. Clear signage, provided by building management, and observant



640 Fifth Avenue exterior

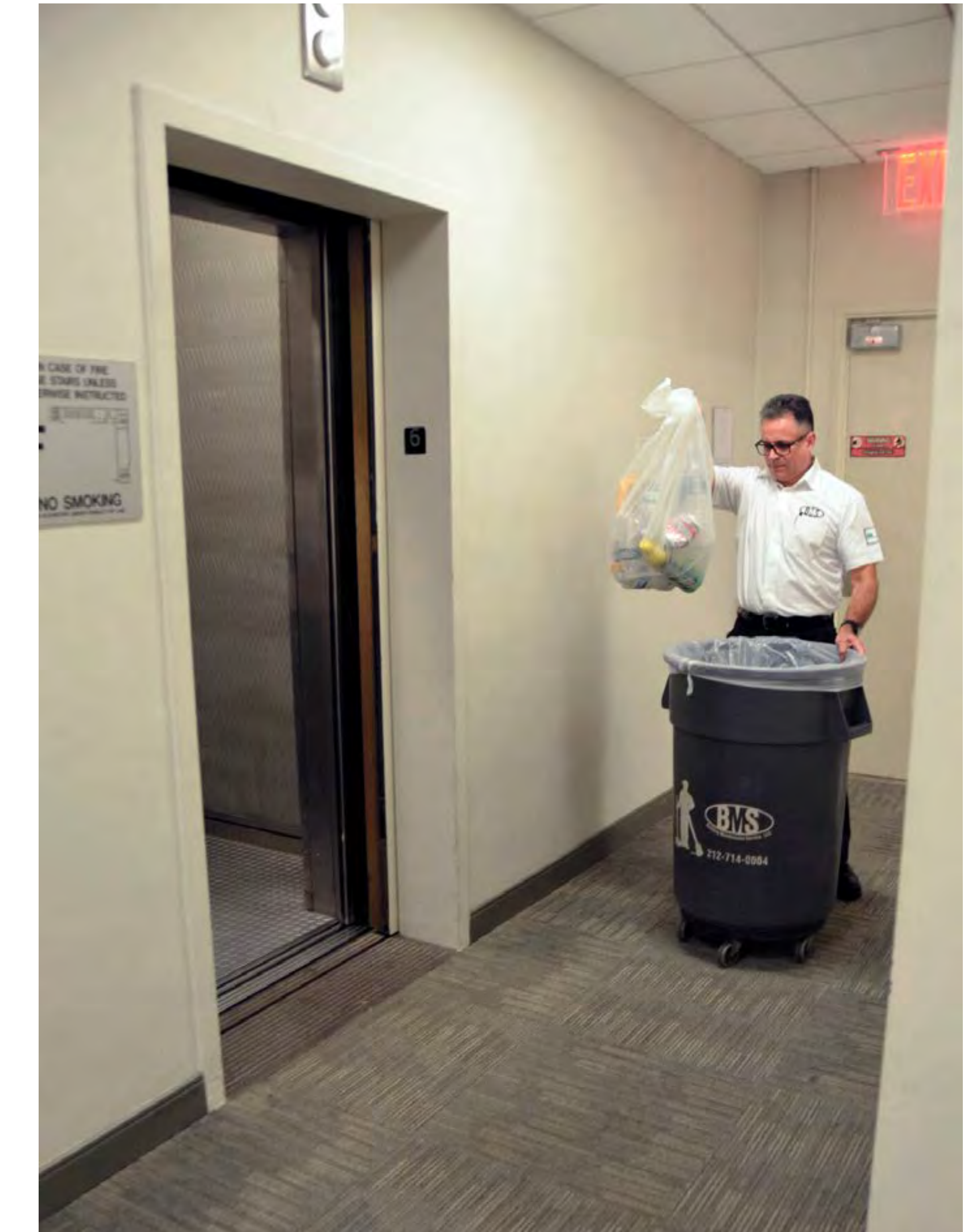

Collection of recycling from office spaces by Building Maintenance Service (BMS) employee

coworkers at these central waste stations help promote proper separation protocol. Vornado has developed consistent signage for tenants used throughout their NYC portfolio. Central storage is provided in the building's cellar for bulk waste, C&D waste and e-waste.

Each night, building staff collects trash and recycling from each floor's containers using bins-on-dollies. These are brought down the service elevator to the cellar where the bags of trash and recycling are transferred to tilt trucks. The tilt trucks are wheeled to the street, where bags are set out for collection by the hauler's recycling and garbage trucks.

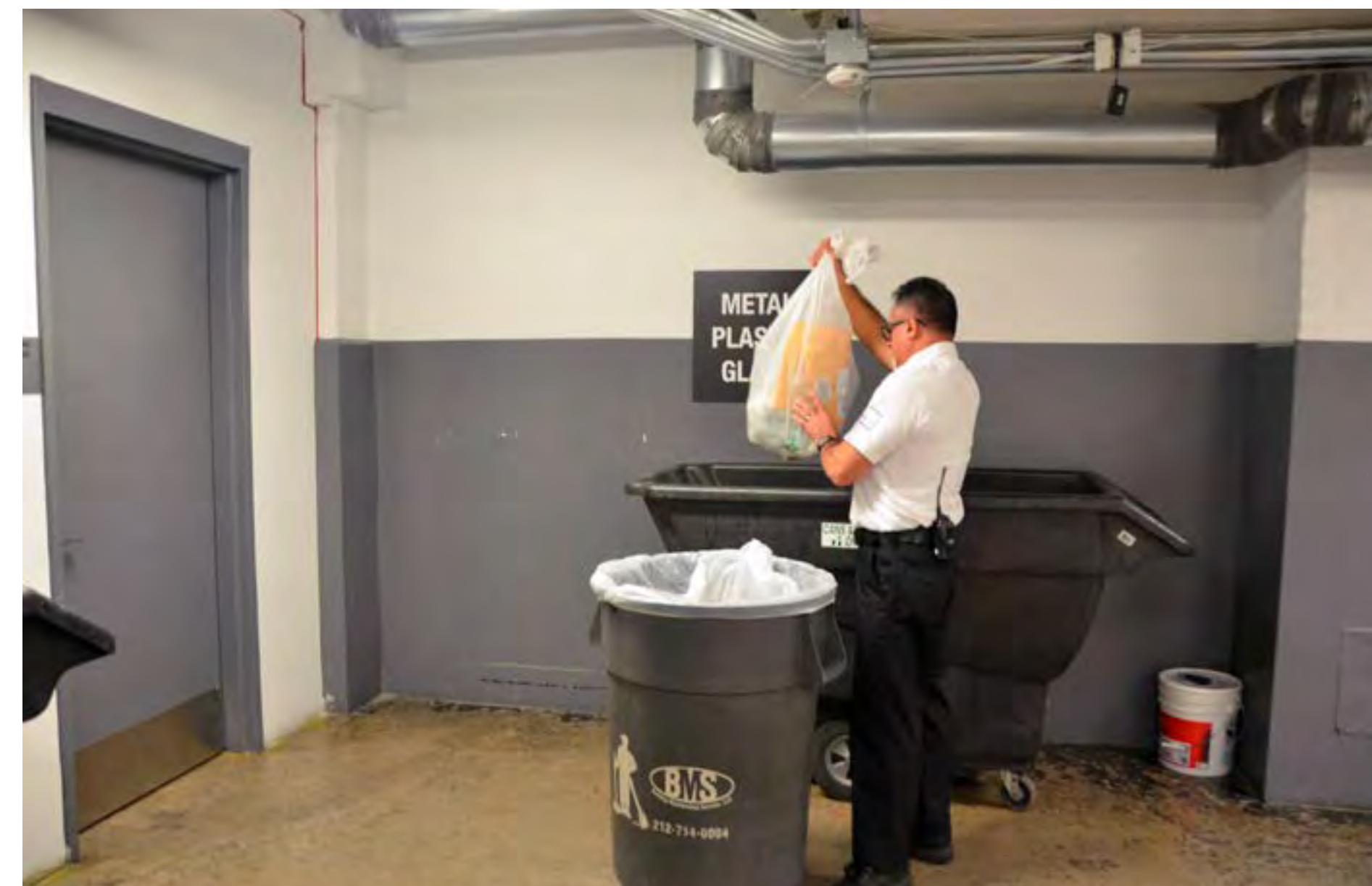

Waste and recycling bins and recycling signs in corporate office kitchen; transfer of recycling from bin on dolly to tilt truck for movement to street; e-waste recycling storage; bulk waste collection containers in storage area

Challenges

Staff have a limited window of time in which to collect and move discarded materials from office spaces to the sidewalk for pickup. Tenants are required to store trash and recyclables in their office spaces until staff collects it at night. If there's a disruption in the hauler's collection schedule, discarded materials can pile up in the building's central storage area or on the sidewalk, where fines may be issued.

VORNADO SUSTAINABILITY

Rigid containers and packaging go to the pantry for recycling!

Glass, metal and plastic containers can be recycled if they are made of rigid materials. Film plastics (plastic bags, candy wrappers and chip bags) cannot be recycled - they go in the trash.

THIS INCLUDES:
 aluminum foil
 plastic take out containers
 beverage cartons
 rigid plastic
 metal cans
 glass jars and bottles

DOES NOT INCLUDE:
 plastic film
 plastic bags
 chip bags
 candy wrappers

Rinse and place all glass, metal, and plastic beverage containers in the designated bins located in pantry areas. Place all plastic lined cartons (i.e. milk, soup, juice) in GMP bins.

Vornado Realty Trust corporate recycling signage for glass, metal and plastic.

Etsy Headquarters, NYC

Type

- Commercial Typology 3: Elevator to Shared Storage
- Construction & Demolition Waste Case Study

Best Practice Strategies (Buildings)

- 2.01 Determine waste streams and quantities
- 2.02 Plan a route
- 2.03 Design storage space
- 2.04 Plan for collection
- 2.05 Consider staff procedures
- 2.09 Provide equal convenience disposal
- 2.10 Provide clear visual cues and signage
- 2.11 Provide opportunities for feedback
- 2.12 Develop awareness and education programs
- 2.14 Design for occupancy
- 2.16 Reduce material consumption
- 2.18 Facilitate donation and reuse
- 2.20 Design to incorporate transparent pricing by stream

Best Practice Strategies (Construction & Demolition)

- 2.25 Maximize asset utilization through programming
- 2.26 Design to optimize material usage
- 2.29 Reuse building and materials on-site
- 2.30 Use reclaimed components and materials
- 2.31 Specify recyclable materials with high recycled content
- 2.32 Require a construction waste management plan
- 2.34 Separate construction waste on-site

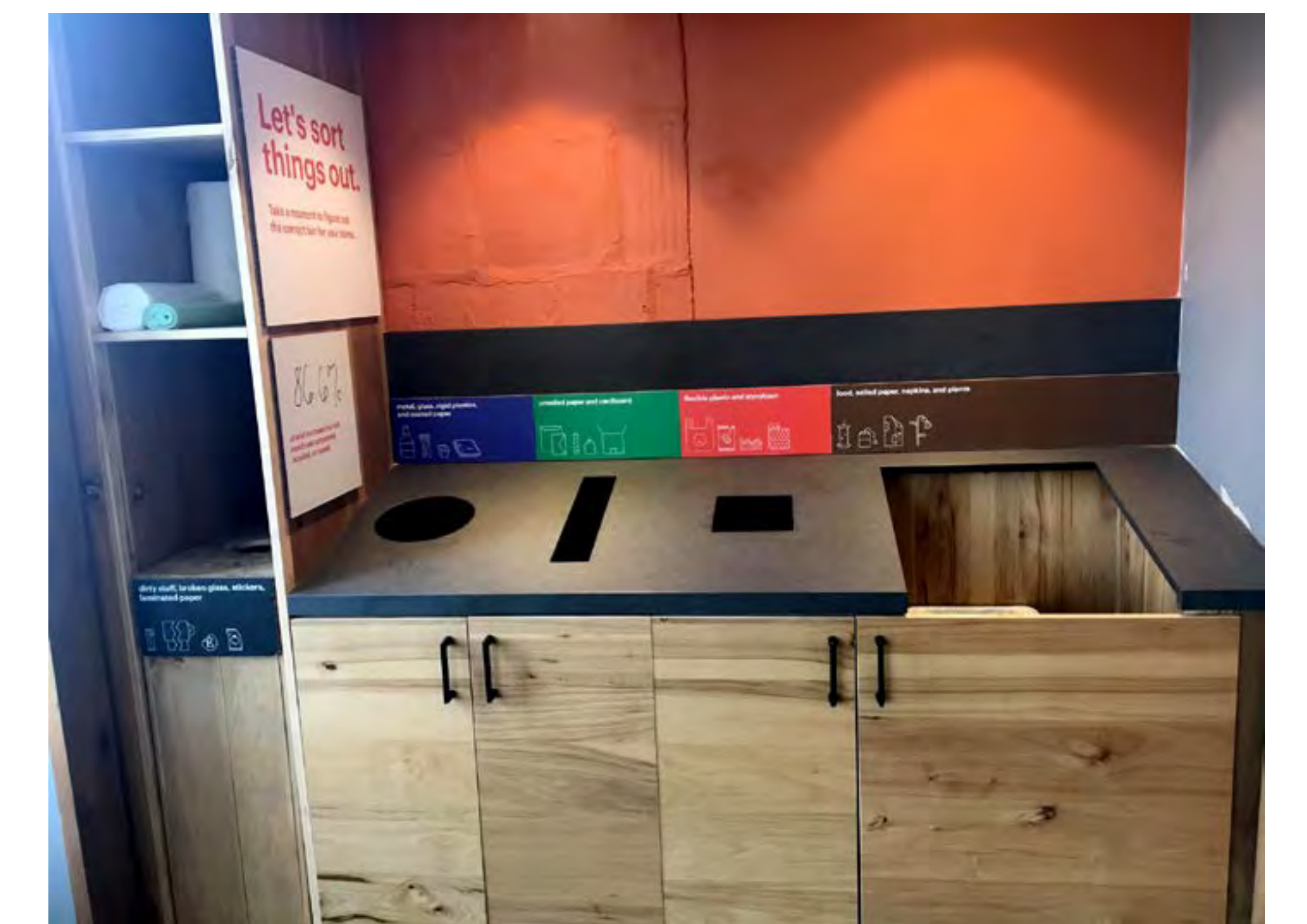
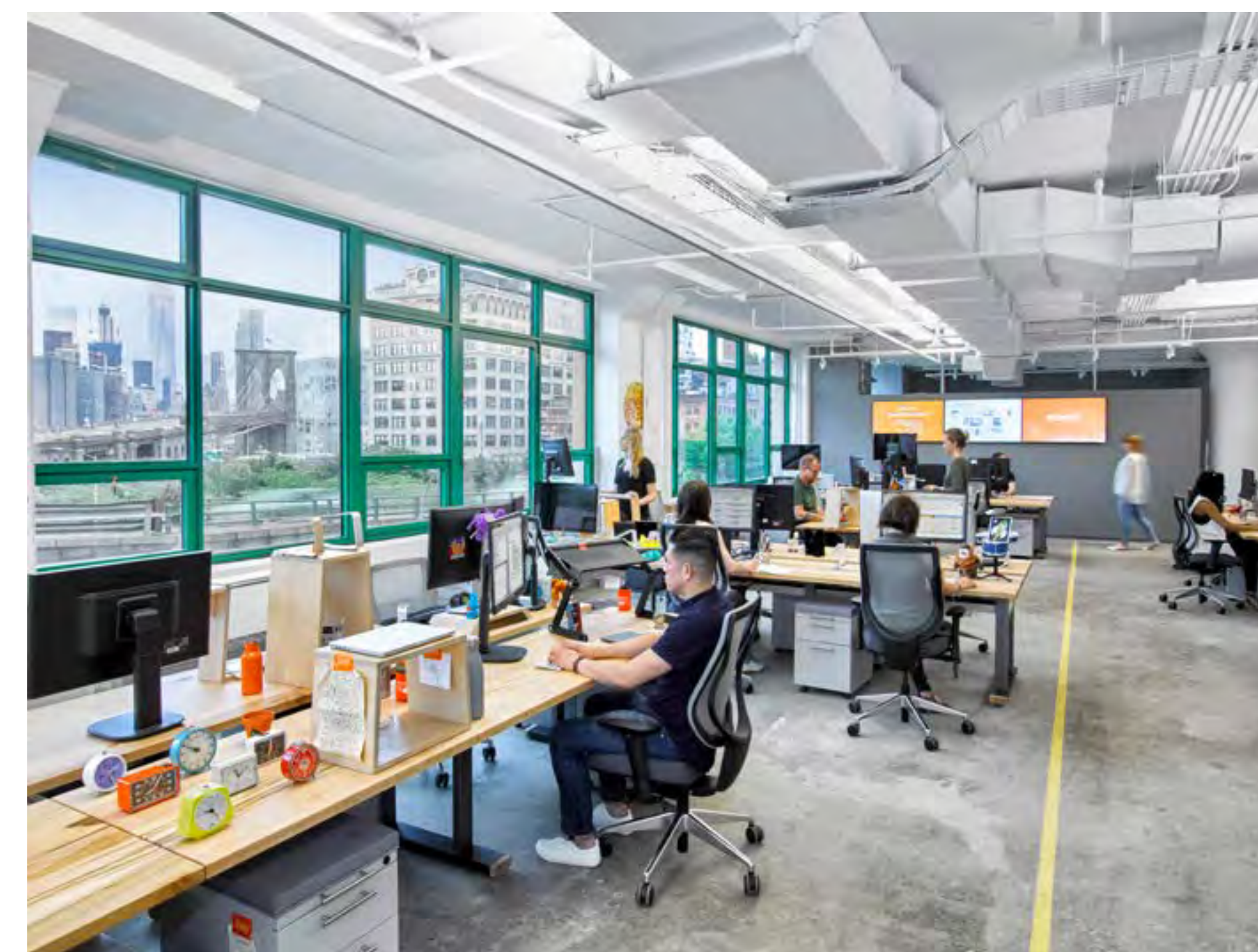

Etsy's workspaces and central waste station

Summary

Etsy's Brooklyn headquarters occupies 200,000 sq ft of a nine-story building constructed in 1924. The renovation, by Gensler, was designed to be zero waste within both its construction and its ongoing operations.

Etsy formalized its zero waste vision in 2017 by publicly announcing their commitment to run zero waste operations globally by 2020. Since then, the office has also been certified as a Zero Waste Facility at the Platinum level. The project also achieved Living Building Challenge Petal Certification. The project was envisioned as an opportunity to instigate change, set a new standard for sustainable construction and design, and create a space reflective of its values, especially those focused on community, craft and sustainability. The building strives to be not just a self-sustaining workplace but also an asset to the community, enriching its Dumbo neighborhood.

During construction, the project diverted over 90% of waste from landfills, with excess materials sent to nearby building projects through a partnership with Big Reuse, a local nonprofit. An inventory of the existing Etsy offices and the new project site identified early opportunities for extensive salvage and reuse, including more than 750 furniture pieces, food service equipment and art commissions inspired by—and incorporating—legacy materials (such as employees' old hand-painted desks). From the new project site, more than 1,150 linear feet of reclaimed wood from water towers and ten industrial doors honor the building's legacy as a printing and publishing house. Reclaimed local wood scaffolding accents the pantry areas and coat closets throughout the project.



Floor plan with waste stations highlighted in red

In the company's previous location, the absence of a dishwasher meant the twice-weekly lunch program was served on single-use, compostable dishware. In the design of this building, space was assigned on each floor for dishwashers and the storage of bussing bins, along with an accessible freight elevator to move the reusable dishes throughout the building's nine floors.

To help diminish the volumes of trash and recycling as well as the time building staff spend moving waste, there are no individual wastebins under desks. Employees bring their waste to one of the three or four per-floor custom-built recycling stations, sited beside central pantries.

The stations are designed to change the behavior of staff members. The opening of each receptacle indicates the specific waste stream: There's a small square opening for trash (labelled 'landfill'), a very large opening for organic waste and a long slot for cardboard and paper products. Clear signage, with illustrations accompanying text, spells out what can and cannot be disposed of in each stream. The onboarding tour of the facilities for new employees includes education around the company's sustainability commitments, as well as a visit to the waste stations to ensure proper sorting habits. The sustainability team operates a Slack channel employees can use to find out if a particular material is recyclable or compostable.

The design of the renovation considers the movement of waste from the point of disposal through to setout. Maintenance staff transports the waste in tilt trucks from recycling stations to the freight elevator, which opens directly onto the first-floor loading area. Storing all waste there allows for ample, well-labeled storage and convenient collection.

Built-in bulk storage was provided to allow for smart consumption. Integrating adequate storage for kitchenware, food and janitorial products allows for bulk purchasing, both in unit size (e.g., 5 gal. hand soap versus 12 oz bottles) and purchase frequency, reducing waste from packaging materials. Food and drink also come unpackaged: Drinks are on tap and employee snacks are stored in glass jars. Lunch, offered twice a week in the dining area, is served on reusable dishware.

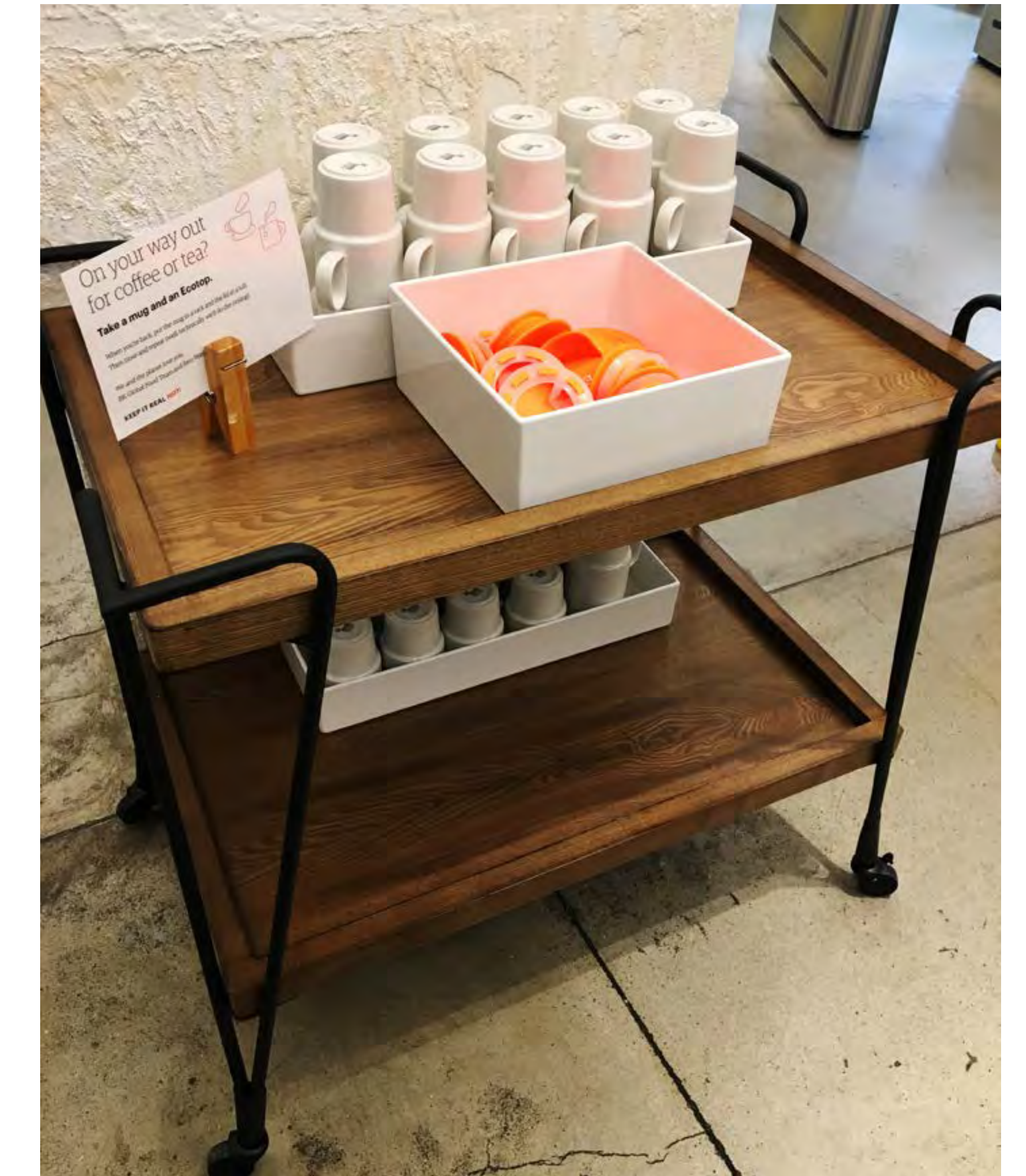

Clockwise from top left: Hamper with scale and tablet with divertsy software; Reusable to-go cups; Central pantry

To reduce the amount of building waste, Etsy implemented Divertsy, a system to track outgoing material streams such as landfill, recycling, compost, e-waste and donations. When the staff collect waste from the stations, it is weighed in the tilt truck, and staff record the numbers on a tablet. The data is used to track progress and explore ways to reduce waste across streams. Divertsy also allows the company to cross-check data with invoices from waste haulers, to confirm their charges are fair. In an effort to engage employees and motivate behavioral change, the company has live data dashboards throughout the office, which display feedback on waste diversion. Employee engagement events such as clothing swaps are held; there's also an annual dumpster dive, in which employees sort through the day's waste.

Challenges

A major source of outgoing waste streams, the company discovered, was the packaging from local food purchases. Now employees exiting the building are offered reusable mugs, with secure tops that turn them into to-go coffee mugs (photo). The employees return the mugs and covers, which are washed in their dishwasher. Employees are regularly reminded—via e-mail and on the internal communications platform—of local coffee shops that offer discounts to those who bring a mug.



Employee engagement events: clothing swap and organic waste from annual dumpster dive

theMART, Chicago

Type

Commercial Typology 4: Service elevator to shared compactor containers

Best Practice Strategies

- 2.02 Plan a route
- 2.03 Design storage space
- 2.04 Plan for collection
- 2.05 Consider staff procedures
- 2.07 Considerations for multi-tenant buildings
- 2.09 Provide equal convenience disposal
- 2.10 Provide clear visual cues and signage
- 2.11 Provide opportunities for feedback
- 2.12 Develop awareness & education programs
- 2.14 Design for occupancy
- 2.15 Provide shared assets and services
- 2.20 Design to incorporate transparent pricing by stream
- 2.22 Volume Reduction Equipment

Summary

TheMART (formerly the Merchandise Mart), a 4.2 million sq ft building spanning two city blocks, is the largest privately held commercial building in the US, a wholesale design center, and one of Chicago's premier venues for international business events. On average, 25,000 people visit theMART each weekday (nearly 10 million a year).

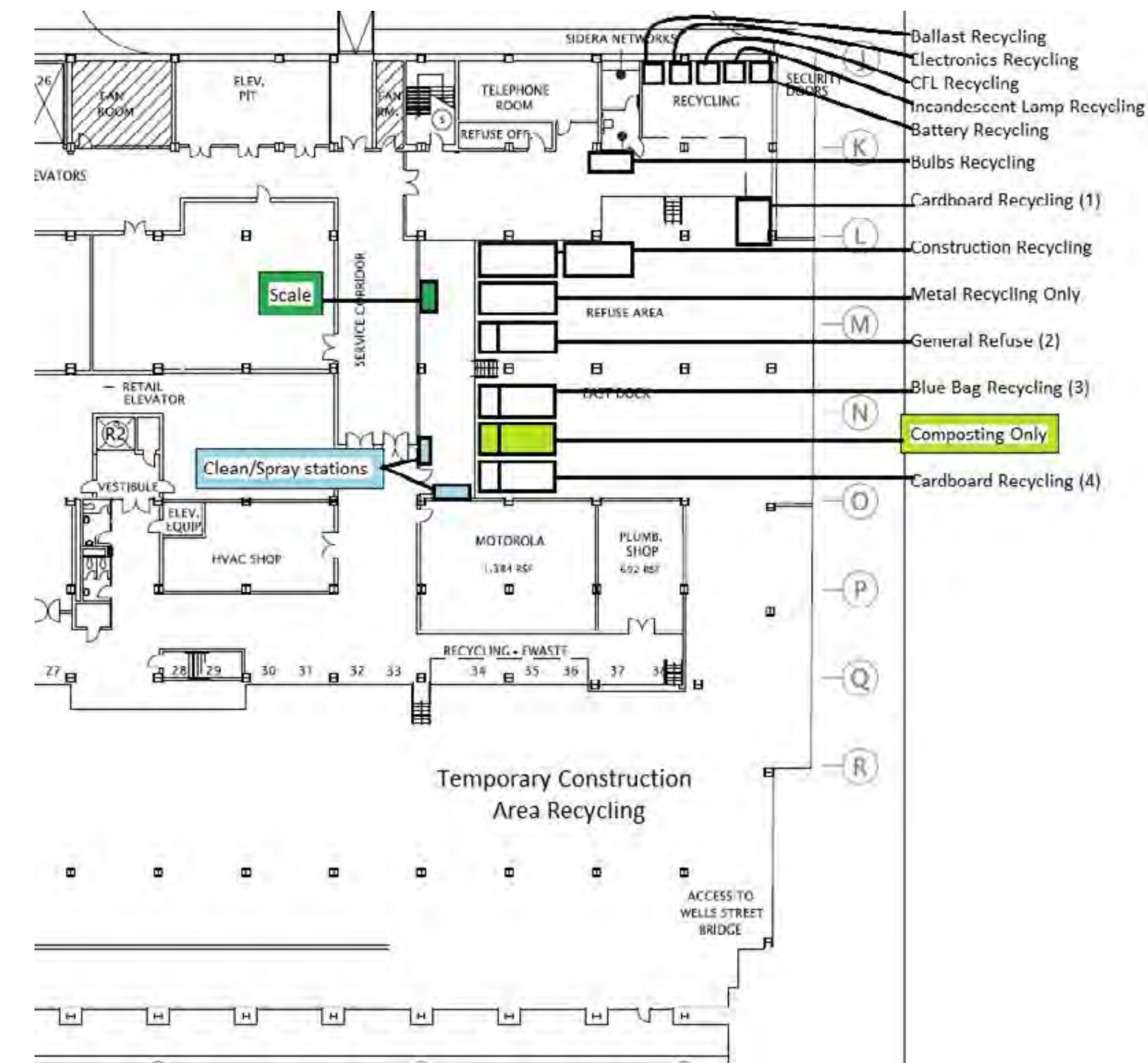

Above:
TheMART exterior view

Left:
Floor plan of shared
waste separation
and storage area

TheMART is owned and operated by Vornado Realty Trust. To maximize diversion rates, Vornado has designed shared building spaces and waste storage areas to promote proper separation of recyclables and organics. Building staff provide training for tenants. In office spaces, central waste stations have replaced general-purpose bins at desks, creating a level playing field for recycling collection. The recycling stations utilize clear visual cues and signage to promote proper separation. In operation since 2008, theMART's organics program has enabled 27 food service and office tenants to divert nearly 100 tons of organic waste per year. In addition to food waste, Vornado's building maintenance team also composts paper towels from all the bathrooms in the building.

Building staff use tilt trucks to move office tenants' waste and recycling materials through service corridors to a loading dock. Retail tenants transport their materials similarly, and more than 60 of them participate in a program to measure their waste volumes and diversion rates. Before being staged for pickup, the tenants' waste and recycling materials are weighed, and the results are entered manually in a database. The data is then analyzed and used to provide tenants with feedback on the success of diversion and reduction efforts. Although not currently in practice, the system could be used to bill tenants based on the amount of material collected rather than typical flat fee based on tenant square footage and business type.

Challenges

The existing scale system Vornado uses to weigh tenant waste requires manual data entry. To simplify the process for staff, the team is working on upgrading the system so that data is entered into the system automatically.

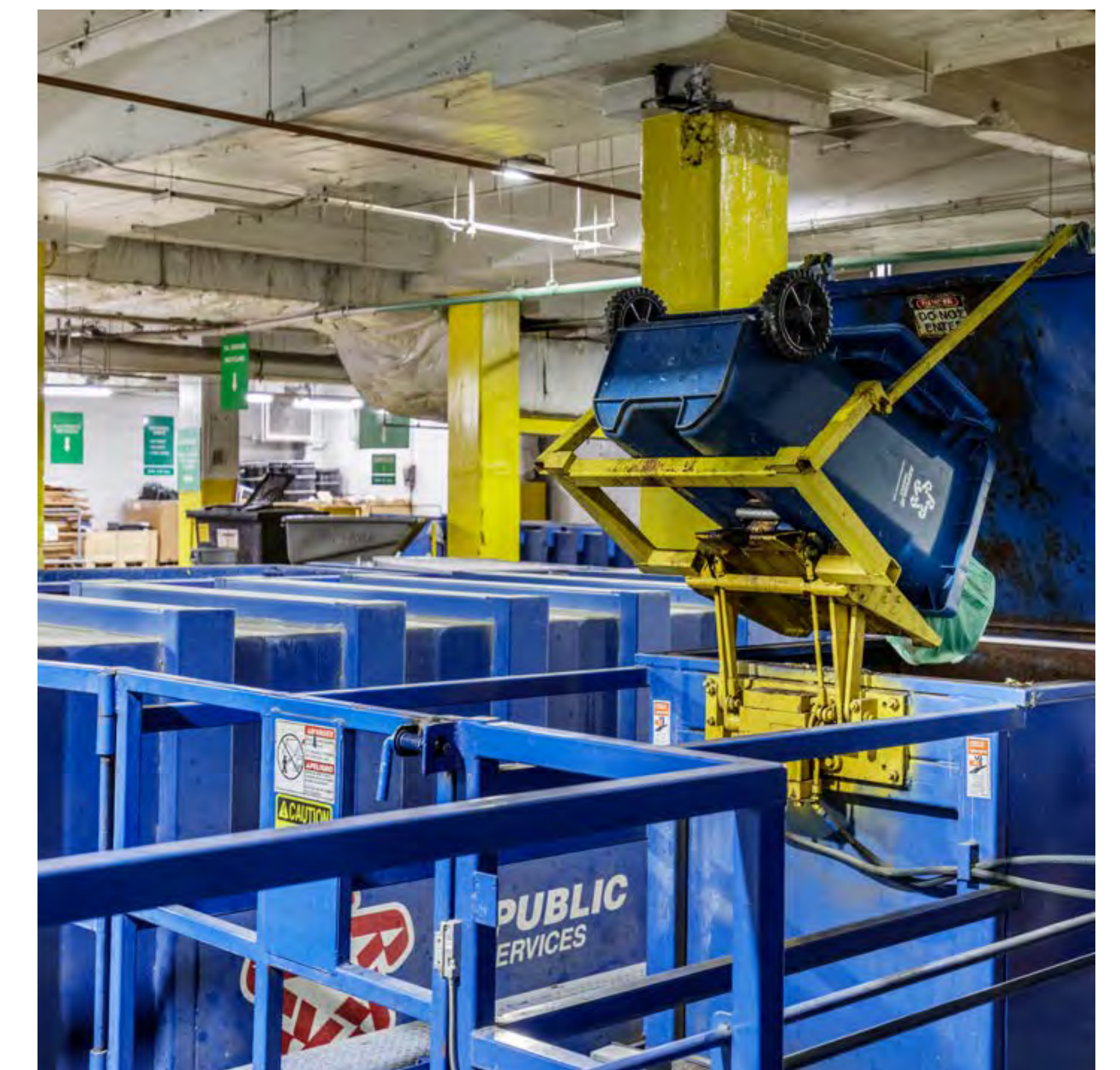
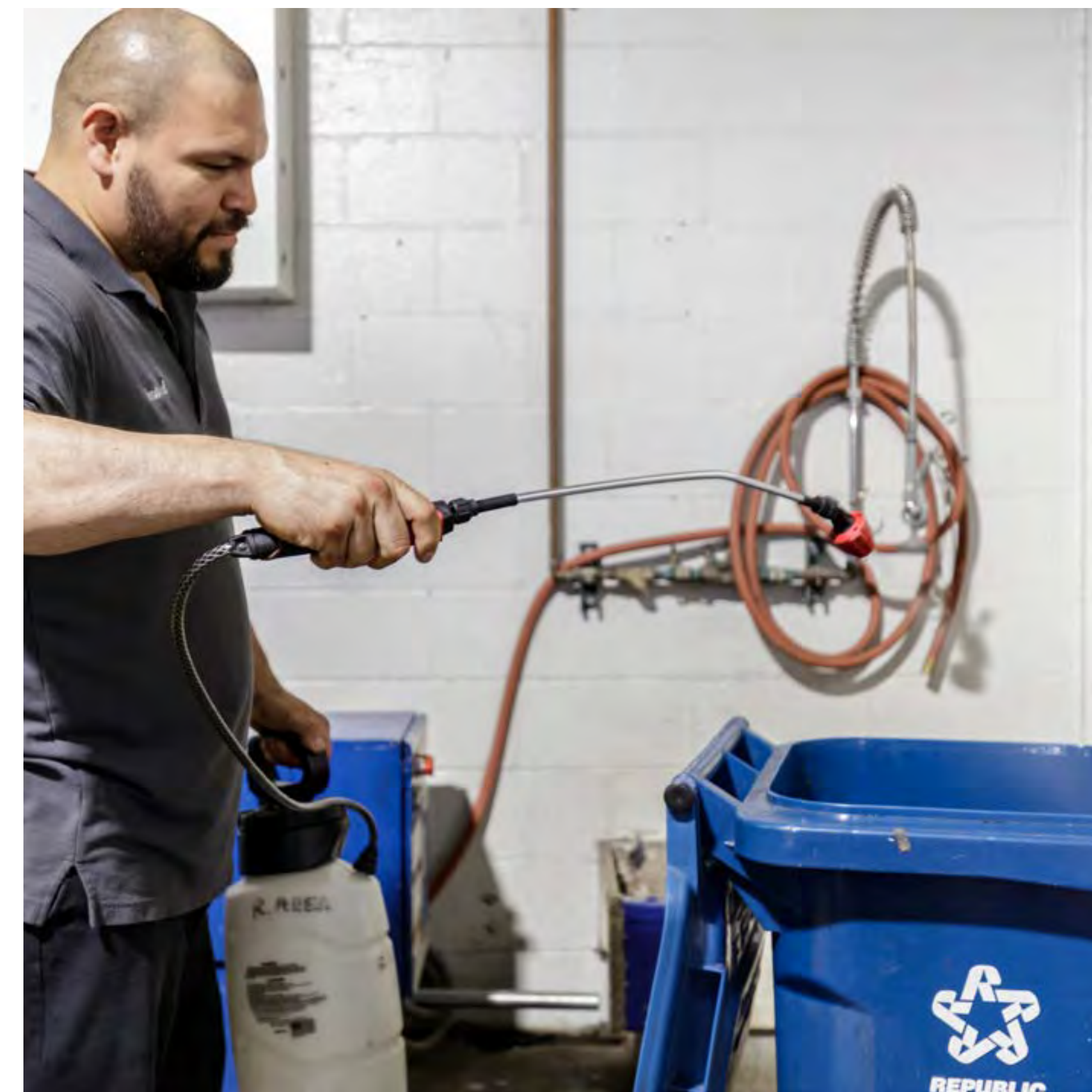
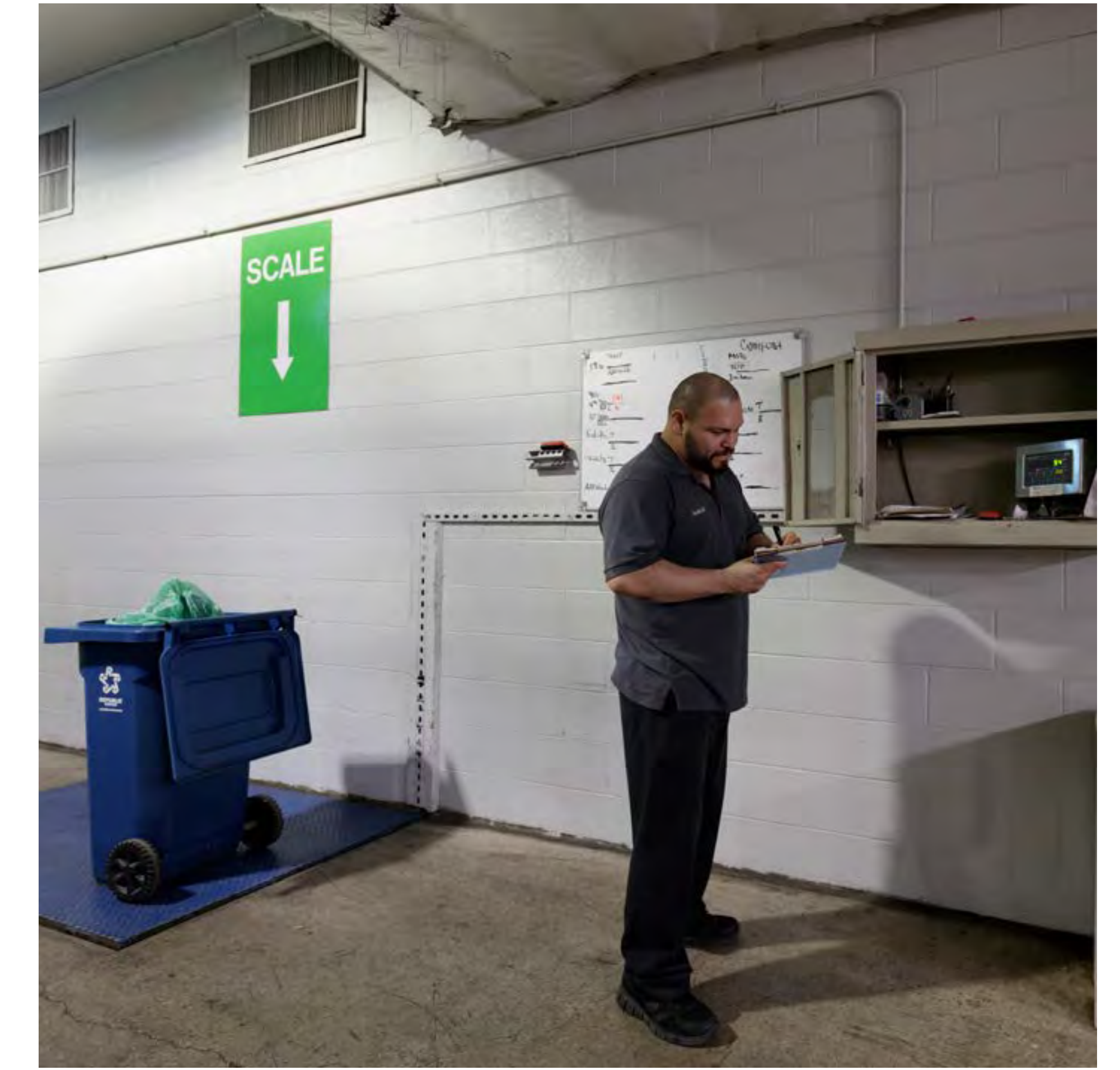

Office recycling collection; scale at loading dock for weighting tenant recycling stream; bin washing station; compactor outfitted with bin tipper

Eataly Boston

Type

Commercial Typology 4: Service Elevator to Shared Compactor Containers

Best Practice Strategies

- 2.01 Determine waste streams and quantities
- 2.02 Plan a route
- 2.03 Design storage space
- 2.04 Plan for collection
- 2.05 Consider staff procedures
- 2.06 Plan for takeback of delivery materials
- 2.09 Provide equal convenience disposal
- 2.10 Provide clear visual cues and signage
- 2.11 Provide opportunities for feedback
- 2.12 Develop awareness and education programs
- 2.14 Design for occupancy
- 2.17 Reduce food waste generation
- 2.18 Facilitate donation and reuse
- 2.22 Volume Reduction Equipment

Summary

Every location of the Italian marketplace Eataly, which offers groceries, restaurants and cooking demos, was designed to ease the separation of organics from trash and recycling, thereby allowing waste to move efficiently through the building. And recently, the chain embarked on a plan to optimize recycling at all its sites, starting in Boston.



Back of house prep station with organics bin

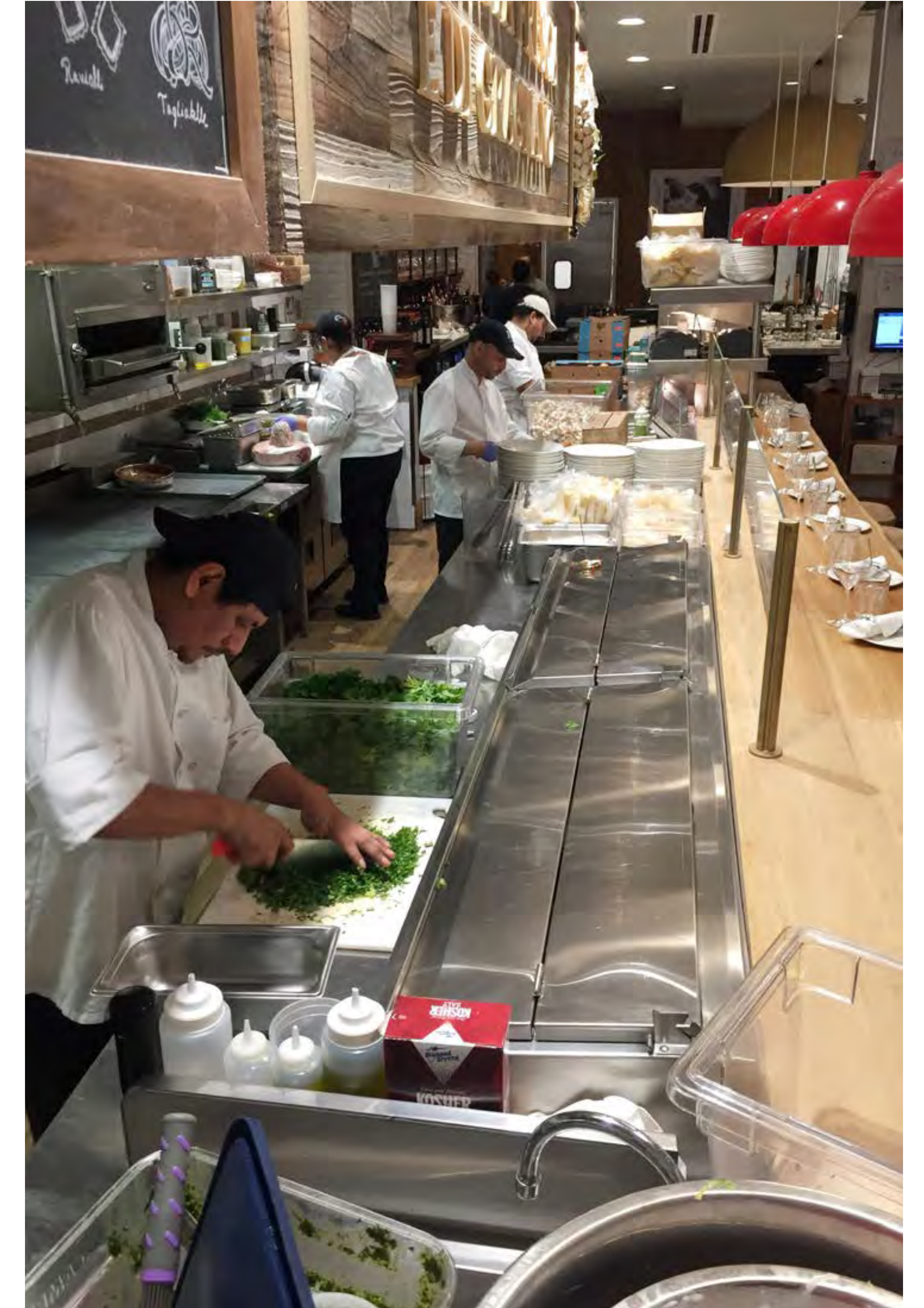

Front of house prep station

BACK OF HOUSE – BINS & DISPOSAL PROCEDURE			
Bin Style	Bag (Color)	Image	Disposal Procedure
Cambro (or any small container)	No bag required		When full empty into nearest toter.
Slim Jim	Green		When full, pull bag & empty into toter in waste storage area.
32g Toter	No bag required		When full take to loading dock compost storage area. Return with empty toter. Note: If no empty toters are available notify John.

Housekeeping standard operating procedure for managing organic waste.

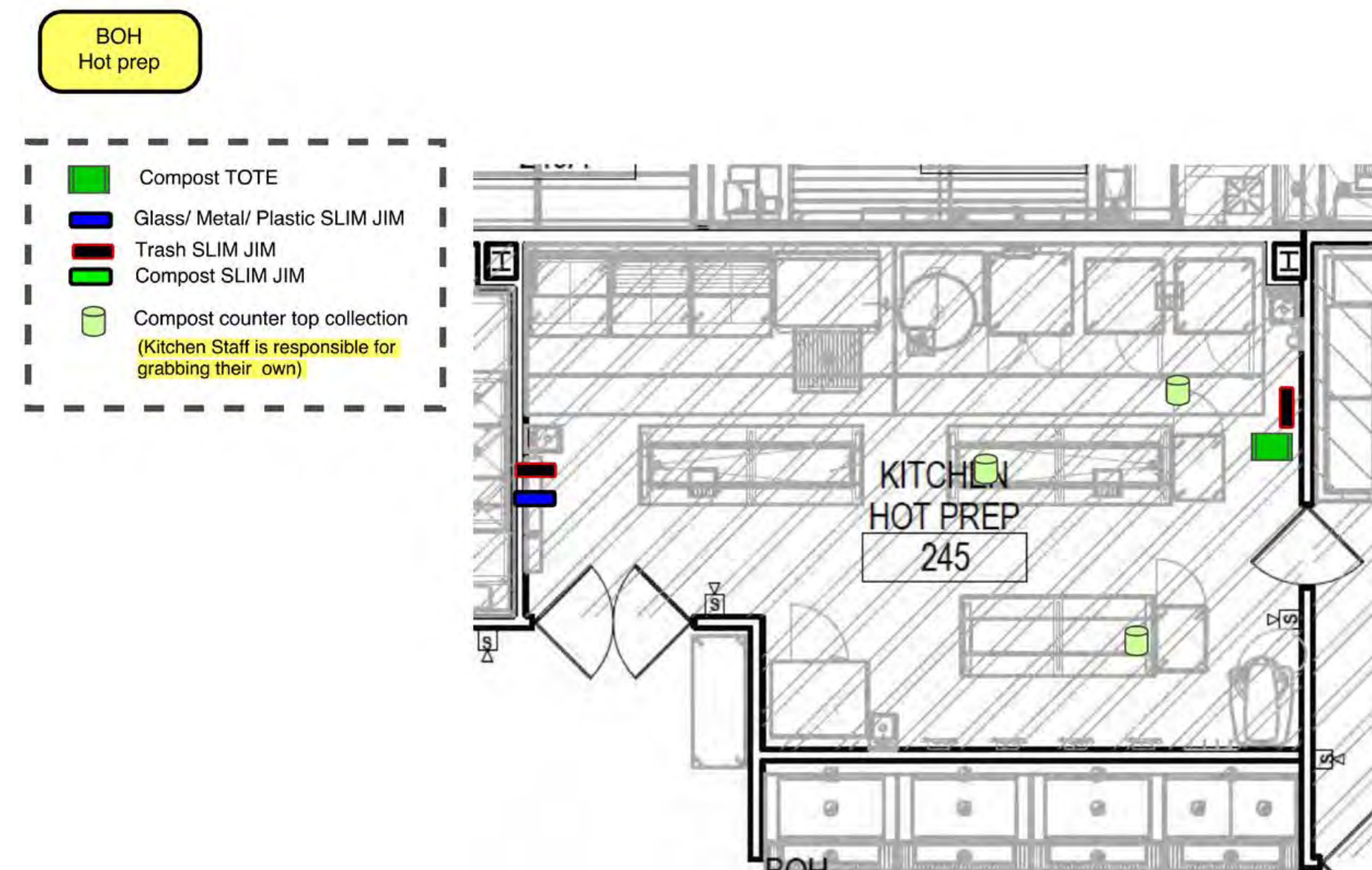

Sample floor plan used by housekeeping staff

A three-story retail and hospitality operation, Eataly Boston features grab-and-go options, four full-service restaurants and a large-scale grocery operation. It is located in the city's Prudential Center, a site with shared compactors for commercial tenants.

All Eataly locations produce many of their own retail food items, from bread to mozzarella. The Boston recycling program relies on color-coded bags in separating and managing each stream. Eataly separates organics, MGP, cardboard and trash. The recycling program is dependent on a simple and comprehensive set of standard operating procedures for general staff, covering waste separation, housekeeping responsibilities, interdepartmental food product transfers and food donations.

The housekeeping team and department staff use floor plans to ensure that at the start of the day, the bins and station are in their designated places. Clear signage in work spaces throughout the back of the house and at the loading dock ensure proper separation procedure is followed at each recycling stage. The signs also indicate the color-coded bins and liner bags for each stream.

A storage area for hampers used for recyclables and trash is clearly marked, with signs and floor tape to limit contamination. Hampers are clearly labeled by stream as well. Staff members transport waste to the loading dock via the freight elevator, without interfering with the shopper's experience. Cooking oil, which is collected twice a week, is stored in special containers.

To reduce food waste, the company instituted a transfer process in which products that can't be used in time by one department are moved to

another for use. The process also ensures that leftover foods are donated to local food rescue organizations Lovin' Spoonfuls and the Women's Lunch Place. Food waste that isn't repurposed is moved directly from the store floor to the loading dock and hauled to a local anaerobic digestion facility to make energy. Eataly also reduces waste and recyclables by working with distributors to take back shipping materials such as pallets and milk crates.

Eataly tracks the daily volume of each recycling stream on-site with a very simple tally sheet. Before transporting compost totes or recycling and trash hampers to the loading dock, the staff record the type of filled container being transported for collection. This data is manually entered and analyzed to track the carbon footprint benefits of diversion and any changes to daily waste streams.

Challenges

- Training is a major challenge for any food business with hundreds of employees. Eataly now integrates recycling into employee orientations and is currently developing handy tools, such as short videos for staff training.
- Customer-facing recycling is complex, particularly in such a highly trafficked facility. Eataly is currently developing standardized recycling stations and new signs to improve guest separation of recycling and organics. To make it easier for customers and to improve the company's environmental footprint, Eataly is also working to increase the use of compostable disposable dishware and eliminate as much disposable plastic as possible.



Above:
Signage for staff



Left:
Back of house recycling storage area with bins in marked locations

Starrett-Lehigh, NYC

Type

Commercial Typology 4: Service Elevator to Shared Compactor Containers

Best Practice Strategies

- 2.01 Determine waste streams and quantities
- 2.02 Plan a route
- 2.03 Design storage space
- 2.04 Plan for collection
- 2.05 Consider staff procedures
- 2.07 Considerations for multi-tenant buildings
- 2.09 Provide equal convenience disposal
- 2.10 Provide clear visual cues and signage
- 2.12 Develop awareness and education programs
- 2.14 Design for occupancy
- 2.22 Volume reduction equipment
- 2.24 Organic waste pretreatment

Summary

For buildings that house diverse businesses, it can be a challenge to promote building-wide, sustainable waste management. Starrett Lehigh—a 2.3 million sq ft commercial building, is doing this through strong tenant collaboration and innovation.

An eco-team has been established at the block-wide building to reduce waste generation and encourage the separation of organic waste by all tenants. In partnership with Vokashi, the compost service, the group



Top to bottom: Starrett Lehigh Building at night; Vokashi counter-top compost container

has distributed bins to promote the voluntary separation of organic waste. Vokashi uses the Japanese method of fermentation called bokashi, providing airtight buckets and “bran” containing microbes to start the composting process. Vokashi then collects the full buckets, leaving clean ones behind, and finishes the process off-site to create a nutrient-dense fertilizer. Ten large tenants currently use the composting system, along with several food vendors in the building. On average, 20 buckets are picked up per week.

The eco-team has also implemented a precycle program, which requires tenants to offer reusable items like office furniture and supplies to fellow tenants—via a building-wide communication system—before they are finally discarded. It’s one way to encourage a sustainable and supportive community.

Tenants place their waste, recycling and full Vokashi organics bins on a service elevator. Building staff then uses the elevator to transport the waste to a storage location at the loading dock, where it is collected nightly. Waste is fed into a 30 cu yd compactor, which is collected five days a week. The loading dock at Starrett Lehigh receives around 4,000 deliveries each week. To keep the large space clean and organized, management posts extensive signage and keeps the waste containers in gated areas.



Shared multi-tenant recycling storage; Recycling signs at Center for Social Innovation

Time Warner Center, NYC

Type

Commercial Typology 4: Service Elevator to Shared Compactor Containers

Best Practice Strategies

- 2.01 Determine waste streams and quantities
- 2.02 Plan a route
- 2.03 Design storage space
- 2.04 Plan for collection
- 2.05 Consider staff procedures
- 2.07 Considerations for multi-tenant buildings
- 2.09 Provide equal convenience disposal
- 2.12 Develop awareness and education programs
- 2.15 Provide shared assets and services
- 2.22 Volume reduction equipment

Summary

The Time Warner Center (TWC), designed by Skidmore Owings & Merrill, marks the southwest corner of Central Park with two 44-story towers rising from a 10-story podium. On the lower levels, a retail mall, restaurants, concert hall and large Whole Foods Market together attract over 16 million visitors annually. The towers are shared a 250-room luxury hotel, 190 condominium apartments and offices. To handle the high volumes and diverse streams of waste flowing through the 2.8 million sq ft operation, the loading dock includes storage space and four compactor containers, one each for organic waste; MPG; paper and cardboard and trash.

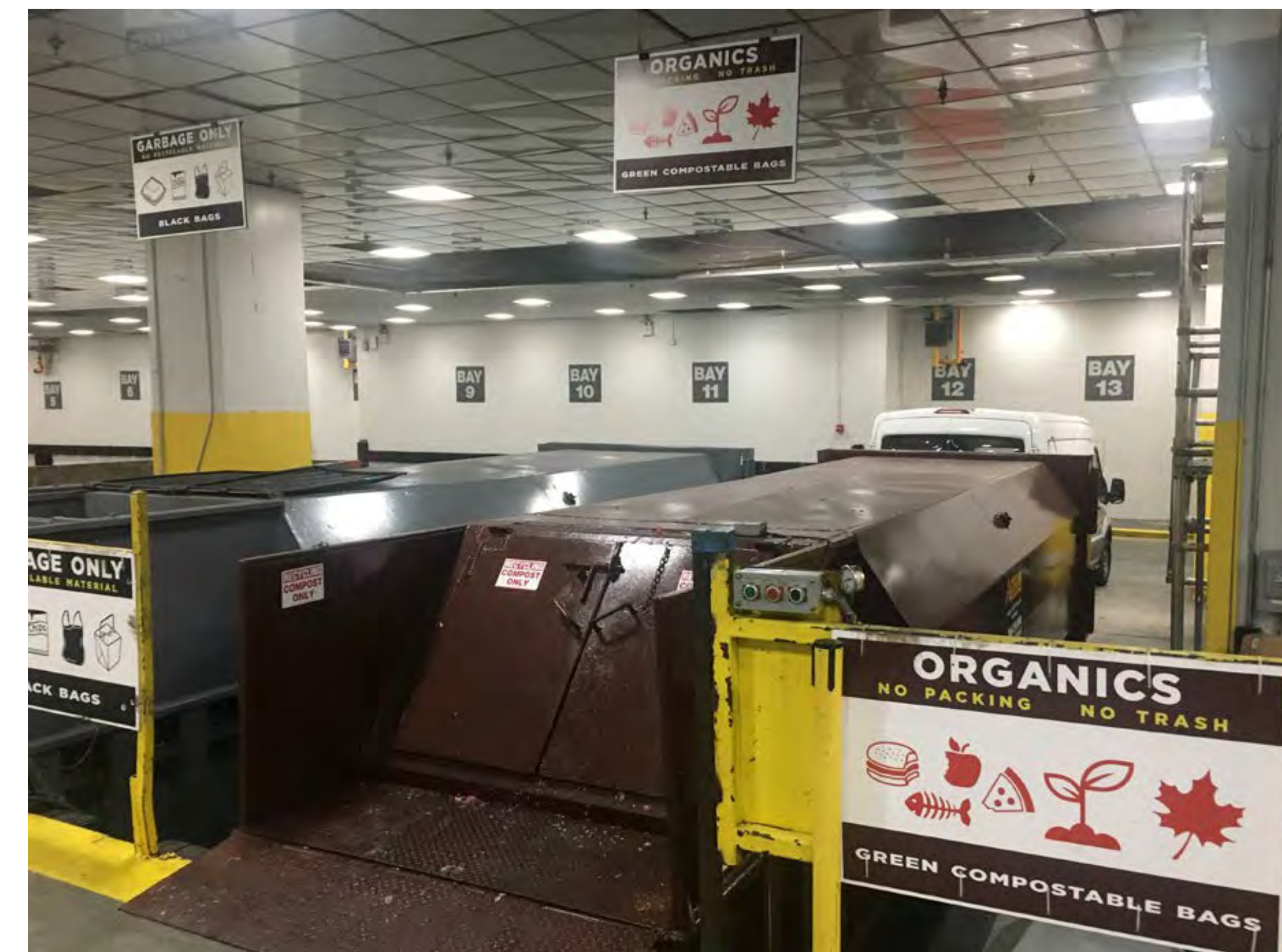

Above:
Section perspective
of Time Warner Center

Left:
Compactor containers
in loading dock

The compactors feature highly visible, clear signs to ensure building staff separate materials correctly. There is also video monitoring for security purposes, which can also be used to identify the source of contamination in recycling compactors. Such monitoring is critical since 10%–15% contamination can result in an entire organics or recycling compactor going to landfill or incineration.

To best coordinate the removal of waste material from a loading dock receiving 250 deliveries each day, building management has arranged for a single carter to collect all four daily waste streams. Shared compactors are available 24/7 in order to accommodate the different business needs of the building occupants and to minimize the area that must be allocated for waste storage. The building rules lay out requirements for use of the compactors in accordance with the city's recycling laws. For the retail component specifically, lease language requires tenants adhere to these rules to ensure that waste is moved efficiently through service corridors and elevators, and tenant staff properly separate materials.

Challenges

As in most buildings, there is no built-in mechanism for tracking occupant use of compactors. Instead, Related, as managing agent for the building, conducts an annual 7-day, 24 hour audit to create the usage allocation by which the building ownership groups are billed. For retail tenants, monthly waste management fees are estimated based on leased space, type of business and other factors. This system creates little incentive for tenants to reduce or divert waste.



Movement of organic waste via freight elevator

Training occupants to avoid contamination is a challenge in a building with so many businesses and frequent tenant staff turnover.

The organics program is used by Whole Foods Market, the largest food waste generator on site, as well as the Mandarin Oriental Hotel. The building operator aims to bring all 10 TWC restaurants into the program ahead of the city's expanded ban of commercial organics, a process that will require extensive staff training.

Columbia University, NYC

Type

Institutional

Best Practice Strategies

- 2.04 Plan for collection
- 2.05 Consider staff procedures
- 2.09 Provide equal convenience disposal
- 2.12 Develop awareness and educational programs
- 2.14 Design for occupancy
- 2.16 Reduce materials consumption
- 2.17 Reduce food waste generation
- 2.18 Facilitate donation and reuse
- 2.22 Volume reduction equipment
- 2.24 Organic waste pretreatment
- 3.02 Provide central collection facility with multiple compactor containers shared between buildings

Summary

In Columbia University's John Jay dining hall students and faculty are served on plates (without trays) and provided with reusable and compostable dishware. Trayless dining limits portion sizes, which means less uneaten food is thrown away. When diners have finished eating, they place their dirty dishes and uneaten food on a dish carousel. The carousel moves the plates to the dish room where trained staff members separate organic waste from other trash. At the John Jay Dining Hall, plate waste is put into a pulper to decrease volume and weight.

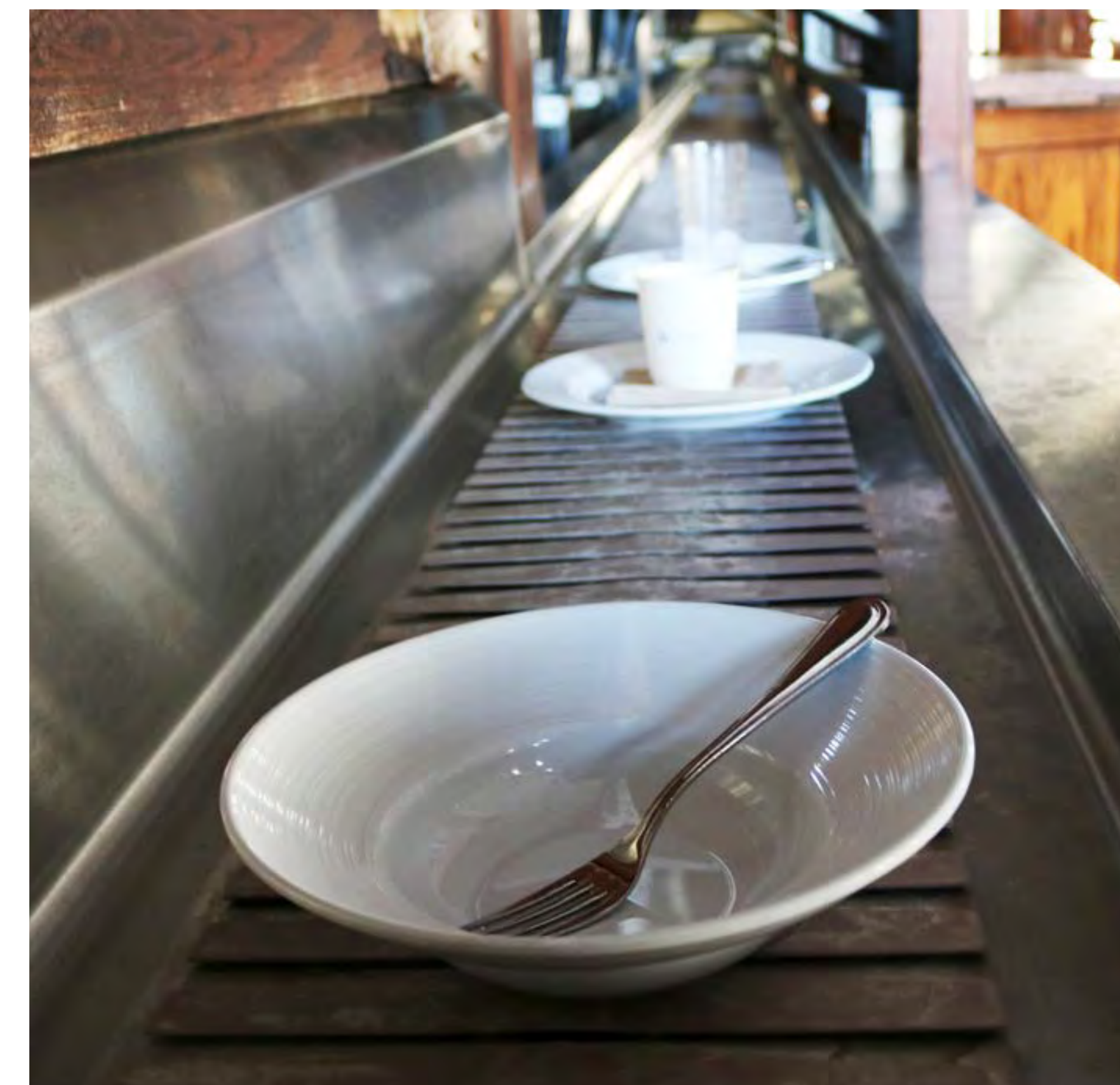

Above:
Compostable and reusable
dishware in John Jay Dining Hall

Left:
Dish carousel

(See [organic pretreatment options](#).) Reusable tableware is washed, and compostable dishware are mixed in with food scraps. The kitchen staff also collects pre-consumer food scraps and used oil from food preparation. Use of dishwashing equipment results in convenience for staff, increased diversion rates, and reduced contamination of waste streams.

Rather than staging waste in front of every building, refuse, cardboard and bulk waste from individual buildings on Columbia's Morningside campus are carted in tilt trucks or driven in small trucks to a dedicated courtyard, and loaded into 30 cu yd containers (four compactor containers for refuse and cardboard and two open containers for recycling and bulk material). Organics from dining venues are collected directly from buildings in wheeled bins.

Columbia has implemented several programs to improve diversion rates amongst residents in its living spaces and classrooms. Students are encouraged to recycle unwanted clothing and e-waste. Additionally, the students host "Give and Go Green" at the end of each academic year, where the Columbia EcoReps sell items left behind in dorm rooms, to prevent them from entering the landfill. In classrooms, programs are in place for separate collection of printer cartridges, lab glass, and solvents. To help the university further reduce the amount of material sent to landfill, Columbia hosts a bi-annual Clean & Go Green event, where faculty and administrators bring unwanted items - clothing, nonperishable food, old paint, e-waste, books and furniture to strategically located containers located on campus, that will later be sorted for donation or reuse.

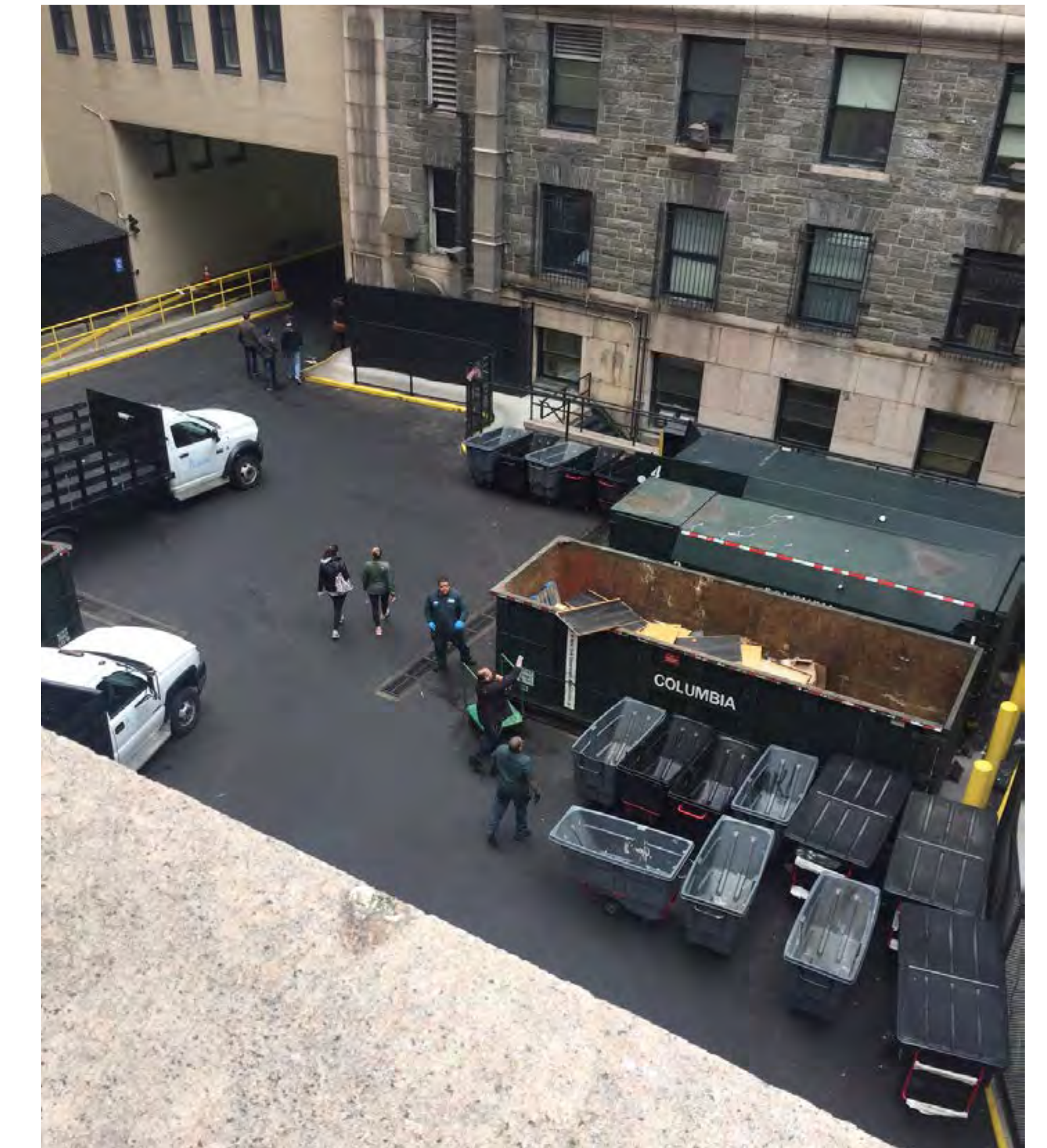

Clockwise from top left: Chemtracker collection bins for laboratory bottles; Central waste collection in courtyard; Pulper breaks down food waste for organic waste collection

Post-Landfill Action Network

Type

Institutional

Best Practice Strategies

- 2.12 Develop awareness and education programs
- 2.16 Reduce materials consumption
- 2.18 Facilitate donation and reuse

Summary

All colleges and universities generate large volumes of waste that can be diverted, as the [Columbia University example](#) shows, but not all possess the resources to develop solutions or the campus culture to support them. The Post-Landfill Action Network (PLAN) is a nonprofit organization that works with college and university students and staff to introduce zero waste projects on-site, such as managing year-end move-out programs, opening free stores and banning single-use plastics and tins campaigns for reusable to-go containers in cafeterias. PLAN serves upwards of 80 member schools—New York City’s Fashion Institute of Technology among them—offering everything from online workshops to an annual Students for Zero Waste Conference and guides on topics such as eliminating disposable containers on campus and the *Free and Thrift Store Manual*.

Challenges

Finding space to store items over the summer can be difficult, particularly in urban campuses.



University of New Hampshire
move-in sale

References

1. “When social norms are visible to everyone (e.g. using a recycling bin), Vining and Ebreo (1992) show that participation rates are higher.” Ankinée Kirakozian, “One Without the Other? Behavioural and Incentive Policies for Household Waste Management,” in *Journal of Economic Surveys* 30, 3 (2016): 542.
2. The digital key may calculate times the chute is used rather than exact volume.
3. See note 2
4. See note 2
5. Verbal correspondence with urban designers, New York City Department of City Planning, September 11, 2017.
6. See note 2
7. “Private Carter Study Economic Assessment,” prepared by BuroHappold Engineering for the City of New York (2016): 77, http://www1.nyc.gov/assets/dsny/downloads/pdf/studies-and-reports/Private_Carting_Study-Market_and_Cost_Analysis.pdf.
8. Equal convenience for recycling (not necessarily organics) is the current minimum standard in many cities, including New York. For discussion, see DSNY, “Recycling in Context” (2001), 28, http://www1.nyc.gov/assets/dsny/docs/about_2001-recycling-in-context_0815.pdf.
9. DSNY research—2005 WCS multiunit study.
10. Businesses are starting to use more reusable packaging. See Reusable Packaging Association, <http://reusables.org>.
11. See note 6.
12. Sean Duffy et al., “It Matters a Hole Lot: Perceptual Affordances of Waste Containers Influence Recycling Compliance,” in *Environment and Behavior* 41, (2008): 747, 10.1177/0013916508323737.
13. See Sander Hermsen et al., “Using feedback through digital technology to disrupt and change habitual behavior: A critical review of current literature,” in *Computers in Human Behavior* 57 (4/2016), <https://doi.org/10.1016/j.chb.2015.12.023>.
14. “Multifamily Recycling: Case Studies on Innovative Practices from Around the World,” prepared by Cascadia Consulting Group for Waste Management Snohomish County Solid Waste, King County Solid Waste (11/2012), <http://wmnorthwest.com/2012summary/pdf/multifamilyinternational.pdf>; and Aliza McHugue, “Ensuring Sustainability: The Best Practices in Ambassador Style Programs,” in *Global Green* blog (8/7/2017), <http://www.globalgreen.org/blog/x7ay8pkp8xmznjsksfrb59gy6agfer>.
15. EPA regulates hazardous waste under the Resource Conservation and Recovery Act. For regulations, see US EPA’s “Hazardous Waste Generators,” <https://www.epa.gov/hwgenerators>.
16. DSNY, “New York City Commercial Solid Waste Study and Analysis, Summary Report,” 2012, 39. https://www1.nyc.gov/assets/dsny/docs/about_2012-commercial-waste-study_0815.pdf.
17. “New prevention technologies are emerging, including waste-tracking tools and packaging innovations. Interviews with ReFED Advisory Council members indicated that these technologies have reduced waste by 5% to 35% in initial pilots,” ReFED, “Roadmap to Reduce US Foodwaste by 20%,” 2016, 29, <https://www.refed.com/solutions/waste-tracking-and-analytics>; For example of large-scale pilot see: “WWF, AHLA, Rockefeller Foundation Band Together to Tackle Hotel Food Waste: The three groups aim to develop a toolkit that will help hotels prevent food waste from being generated,” *Waste 360*, 3/22/2017, <http://www.waste360.com/generators/wwf-ahla-rockefeller-foundation-band-together-tackle-hotel-food-waste>.
18. E.g. Food Donation Connection helps food service companies develop and implement food harvest programs, <http://www.foodtodonate.com>.
19. Compaction ratios are from Great Forest.
20. We referred to data from Foodprint Group and Nora Goldstein and Charlotte Dreizen, “On-Site Food Waste Pretreatment: Guide to equipment and systems for businesses, institutions and venues that manage food waste on-site,” in *BioCycle* 58 (2017), <https://www.biocycle.net/2017/07/05/site-food-waste-pretreatment/>.
21. For discussion of costs and benefits of in-sink disposers, see Citizen’s Budget Committee, *Can We Have Our Cake and Compost It Too? An Analysis of Organic Waste Diversion in New York City*, 2/2016, <https://cbcny.org/research/can-we-have-our-cake-and-compost-it-too>.

22. Nora Goldstein, "On-Site Food Waste Pretreatment," 31.
23. See map of WWTP with capacities, "New York City's Wastewater Treatment System," New York City Department of Environmental Protection, 20, <http://www.nyc.gov/html/dep/pdf/wssystem.pdf>.
24. Ellen McArthur, "Growth Within: A Circular Economy Vision for a Competitive Europe" (2015): 20.
25. Organization for Economic Co-operation and Development, *Material Resources, Productivity and the Environment*, OECD Publishing, 2/12/2015, <http://dx.doi.org/10.1787/9789264190504-en>.
26. As defined by the US National Building Information Model Standard Project Committee, building information modeling (BIM) is a digital representation of physical and functional characteristics of a facility. A BIM is a shared knowledge resource for information about a facility forming a reliable basis for decisions during its life cycle; defined as existing from earliest conception to demolition.
27. turntoo company website, <http://turntoo.com/en/material-passport/>.
28. The latex paint reuse model is based on successful programs in Portland, Oregon, Austin and throughout Canada.
29. Cooper Tank Recycling, <http://coopertankrecycling.com/>.
30. US Green Building Council, "Greenbuilding 101: What is an Integrated Process?" 5/7/2014, <https://www.usgbc.org/articles/green-building-101-what-integrated-process>.
31. David Giles et al., "Re-Envisioning New York's Branch Libraries," Center for an Urban Future, 9/2014, <https://nycfuture.org/research/re-envisioning-new-yorks-branch-libraries>.
32. Ellen Galinsky and Eve Tahmincioglu, "Why Citi Got Rid of Assigned Desks," in *Harvard Business Review*, 11/12/2014, <https://hbr.org/2014/11/why-citi-got-rid-of-assigned-desks>.
33. See also WRAP (Waste & Resources Action Programme) Davis Langdon LLP, "Designing Out Waste: A Design Team Guide for Buildings" (site: Press, yr), 24.
34. Frank Duffy's concept described in Stewart Brand, *How Buildings Learn: What Happens after They're Built* (New York: Viking, 1994).
35. Clichy-Batignolles official website, http://www.clichy-batignolles.fr/sites/default/files/pistegrandformat_def_web_anglais_220415.pdf.
36. Correspondence with architect Suzel Brut, Agence d'architecture Suzel Brut, 9/12/2017.
37. Interview with Marie-Eve Perru, director of infrastructure for Paris sanitation and water agency and project manager for the Clichy-Batignolles pneumatic network, 11/23/2016.
38. City of Toronto website, <https://www1.toronto.ca/wps/portal/contentonly?vgnextoid=650da5dffe375510VgnVCM10000071d60f89RCRD>.
39. Aliza McHugue, "Ensuring Sustainability."
40. Cascadia Consulting Group, "Multifamily Recycling," 14-15.
41. Aliza McHugue, "Ensuring Sustainability."
42. City of Toronto website.
43. Cascadia Consulting Group, "Multifamily Recycling," 14-15.
44. See comments from William To, Toronto's coordinator for volunteer management, in Aliza McHugue, "Ensuring Sustainability."
45. NYCHA Environmental Ambassadors, <https://www.grownyc.org/recycling/NYCHA>.
46. The City of New York, the Mayor's Zero Waste Challenge (results), <http://www1.nyc.gov/assets/sustainability/downloads/pdf/Mayor's%20Zero%20Waste%20Challenge%20Final%20Report%20July%202016%20wo%20participant%20info.pdf>.

Collection & Urban Design

176	Collection & Urban Design Context
190	Collection & Urban Design Best Practice Strategies
201	Collection & Urban Design Case Studies
220	References

Collection & Urban Design Context

As the city densifies there is often not enough room on the sidewalks to accommodate the mountains of bags.



Background

Over the centuries and decades, the logistics of collection and transport have changed, from no containers at all to barrels and metal cans to plastic bags and compacting containers. Collection forces changed from all private to (almost) all public to the current system of public collection for residential, institutional and litter bin wastes and private collection of commercial discards.

Because the New York City street grid was laid out without alleys, all material must enter and exit the public face of the building and cross the public sidewalk to get between the building and the street. Since discards are only staged at the curb while they are awaiting pickup, city planners have traditionally excluded them from street design.¹ But the way they are set out on and picked up from the city's sidewalks and streets has a significant impact on the urban quality of life and on residents' and businesses' ability to reduce the volume of waste exported to landfills and waste-to-energy facilities.

Door-to-Door and Aggregated (Shared) Collection

Collection from buildings can be divided into two categories: door-to-door, in which the material from each building is set out in front of it, and aggregated, in which material from multiple buildings is consolidated at a single location. In NYC, nearly all buildings have door-to-door collection, and aggregated collection is typically limited to large developments of multiple buildings under a single management team.



Rear load truck collecting waste door-to-door; Electric cart bringing waste to a shared compactor container for collection

Environmental Impacts

In addition to the obvious local impacts of discards at the curb are the impacts of truck collection on the city as a whole. The trucks that stop in front of every building in the city multiple times a week (or day), idling and compacting, travel about 50 million miles a year.² Compactor trucks average 3 mpg on their routes.³ Collection burns upwards of 10 million gal. of diesel fuel a year, releasing tons of greenhouse gases and other harmful emissions and causing significant levels of congestion. Collection trucks are also a major source of noise complaints.⁴



Loading area with truck making deliveries adjacent to compactor container

Safety Issues

Setting out and collecting wastes and recyclables is one of the most dangerous occupational activities. Sanitation workers, according to the US Bureau of Labor Statistics, are three times as likely to die on the job as are police officers, and 15 times as likely as firefighters.⁵ Garbage trucks in NYC kill four times as many pedestrians as cabs do: 24 people per 100 million miles.⁶ And handling waste is one of the greatest sources of occupational injury for building maintenance staff.⁷

Balancing Diversion from Disposal and Collection and Transport Impacts

The design of the collection process has a direct effect on the volume of material diverted from landfills. For example, a single-stream recycling operation (metal/glass/plastic collected in the same container and truck compartment as paper and cardboard) reduces the number of separate truck trips and truck miles logged. However, while it is possible to sort such a commingled stream after collection, cross-contamination between material types can affect their ability to be processed and marketed, hence their ability to be diverted from disposal. On the flip side, more source-separated fractions will increase truck trips and truck miles traveled. Trucks could collect less frequently if investments were made in storage space or volume-reducing equipment. (See Chapter 2 for [Best Practice Strategies for Building Design](#).)

DSNY Zero Waste Initiatives Concerning Collection

The city is engaged in a number of initiatives that should help reduce both the amount of material disposed in landfills and the impacts of collection. DSNY is considering implementing a save-as-you-throw (SAYT) system, which would provide an economic incentive for reduction and

recycling. It is also developing plans for zoned commercial collection, which should minimize truck miles traveled while producing other desirable effects.⁸ And DSNY is expanding opportunities for drop-off collections of food scraps, textiles, e-waste and hazardous waste, along with special bins for voluntary collections of textiles and e-waste from multifamily buildings.

Deliveries/Reverse Logistics

The inbound flow of deliveries is mirrored by the outbound flow of building discards. However, because collecting discards is considered a waste management problem rather than a distribution logistics issue, transportation planners typically do not include it in models for sustainable “last mile” urban freight transport. Viewed from a zero waste perspective, all these materials should be managed as freight.

Rules/Agency Roles

Because collection takes place at the interface between private property and the street, collection strategies fall under a number of overlapping jurisdictions. DSNY decides what can be set out on the curb—and where and when—and determines the schedule for street cleaning. Meanwhile, the Department of Transportation decides what can be stored or driven on the streets and sidewalks and where cars can park. The Zoning Resolution determines where loading docks and curb cuts are permitted and, along with the building code, what kind of waste storage space is required.

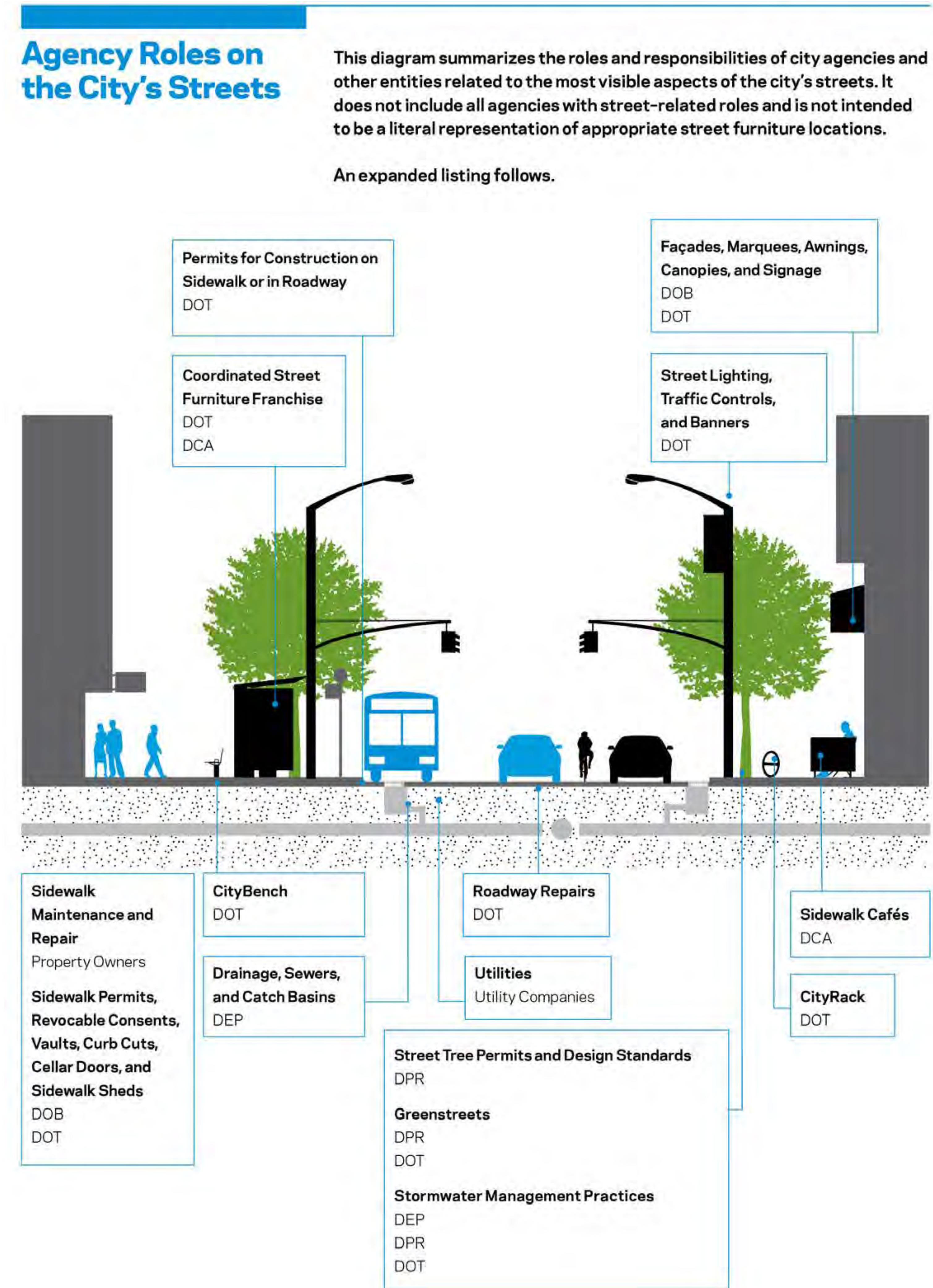

NYC DOT *Street Design Manual*, 2015

NYC RULES FOR SETOUT

Waste storage located inside building

1. **Planting zone** DCP
 - Street trees required one per 25' of frontage
 - Planting strips required for certain districts
 - Zoning Resolution
2. **Sidewalk** DOT
 - 5-foot wide min. (low-density districts)
 - 8-foot clear or 50% sidewalk width (high-density districts)
 - DOT Street Design Manual 2.2.1
3. **Set out timing** DSNY
 - Containers set out after 4pm, before collection day
 - Containers removed by 9am on collection day
 - 16 RCNY § 1-02.1
4. **Bag requirements** DSNY
 - Trash: bin or opaque bag under 44 gallon
 - Recycling: bin or clear bags 13-55 gallon
 - Organics: DSNY approved container (under 35 gallon)
 - 16 RCNY §1-08(e)
5. **Curb cut** DCP
 - Curb cut locations limited to ensure pedestrian safety
 - Zoning Resolution
6. **Loading Docks** DCP
 - Compactor containers are not allowed in required loading docks, but can be in supplemental loading areas
 - Zoning Resolution

7. **DSNY Roll On Roll Off Container** DSNY
 - Approved based on appropriate space, truck access and sufficient volume
 - “Containerized Collection Service Request”
 - DSNY
8. **1-8 cu yd containers** DSNY
 - Must be removed immediately
 - After collection, containers are to be stored inside or at rear of property
 - 16 RCNY § 9-12

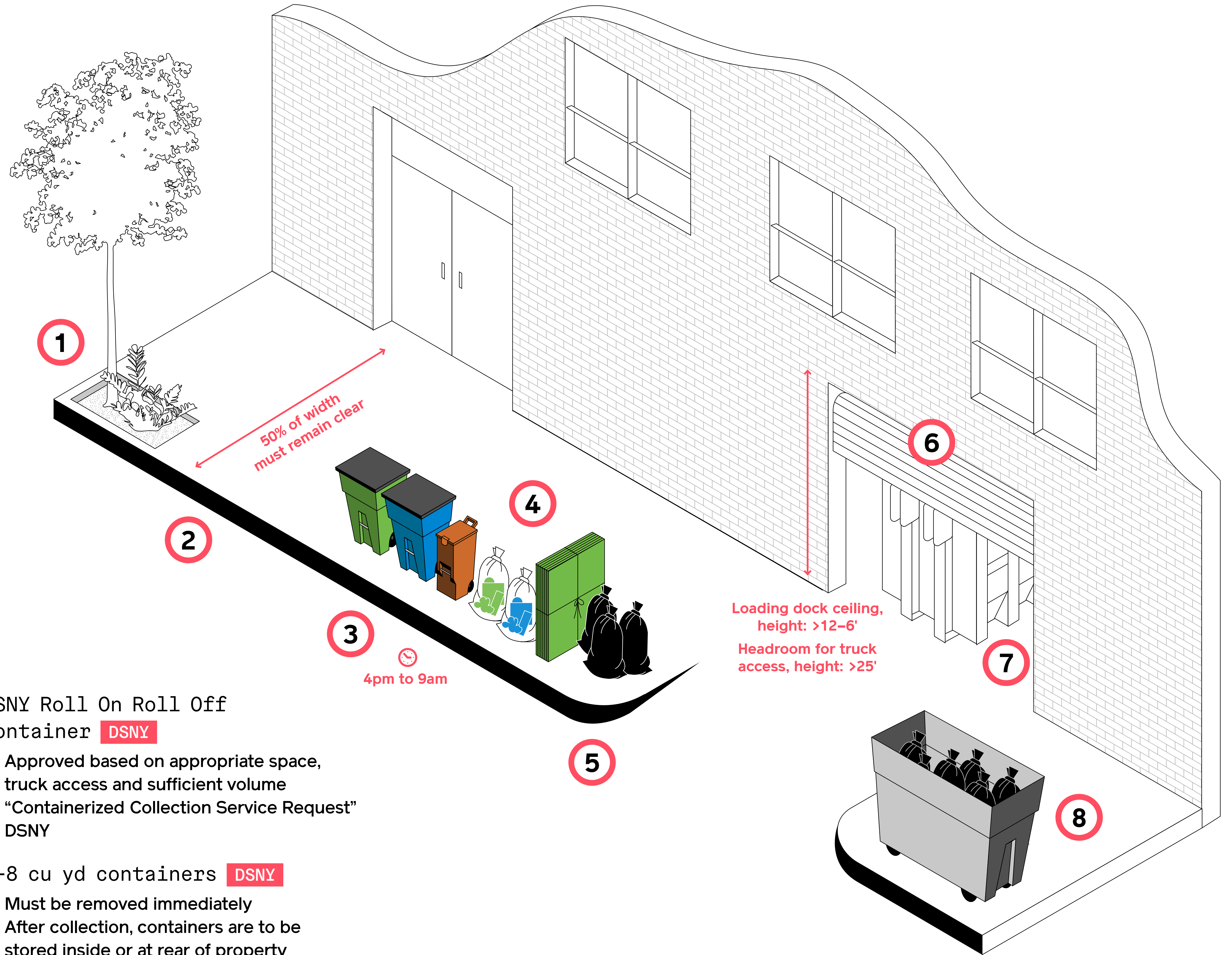

NYC RULES FOR EXTERIOR STORAGE

1. Screened Enclosure (not shown)
 - Open off street loading berths must be screened if adjacent to residential district
 - ZR 36-67
2. Temporary 20-40 cu yd container **DOT**
 - Up to 5 days
 - Within 9 feet of curb
 - “Commercial Refuse Container permit”
 - 34 RCNY §2-03
3. Storage behind the property line **DSNY**
 - If no space available inside
 - 16 RCNY § 1-08f 2(i)
4. Enclosure for trash receptacle **DOT**
 - DOT grants revocable consent for enclosures for trash receptacles, adjoining a building, for private use
 - Renewable, may be revoked at any time
 - 34 RCNY § 7-04.9

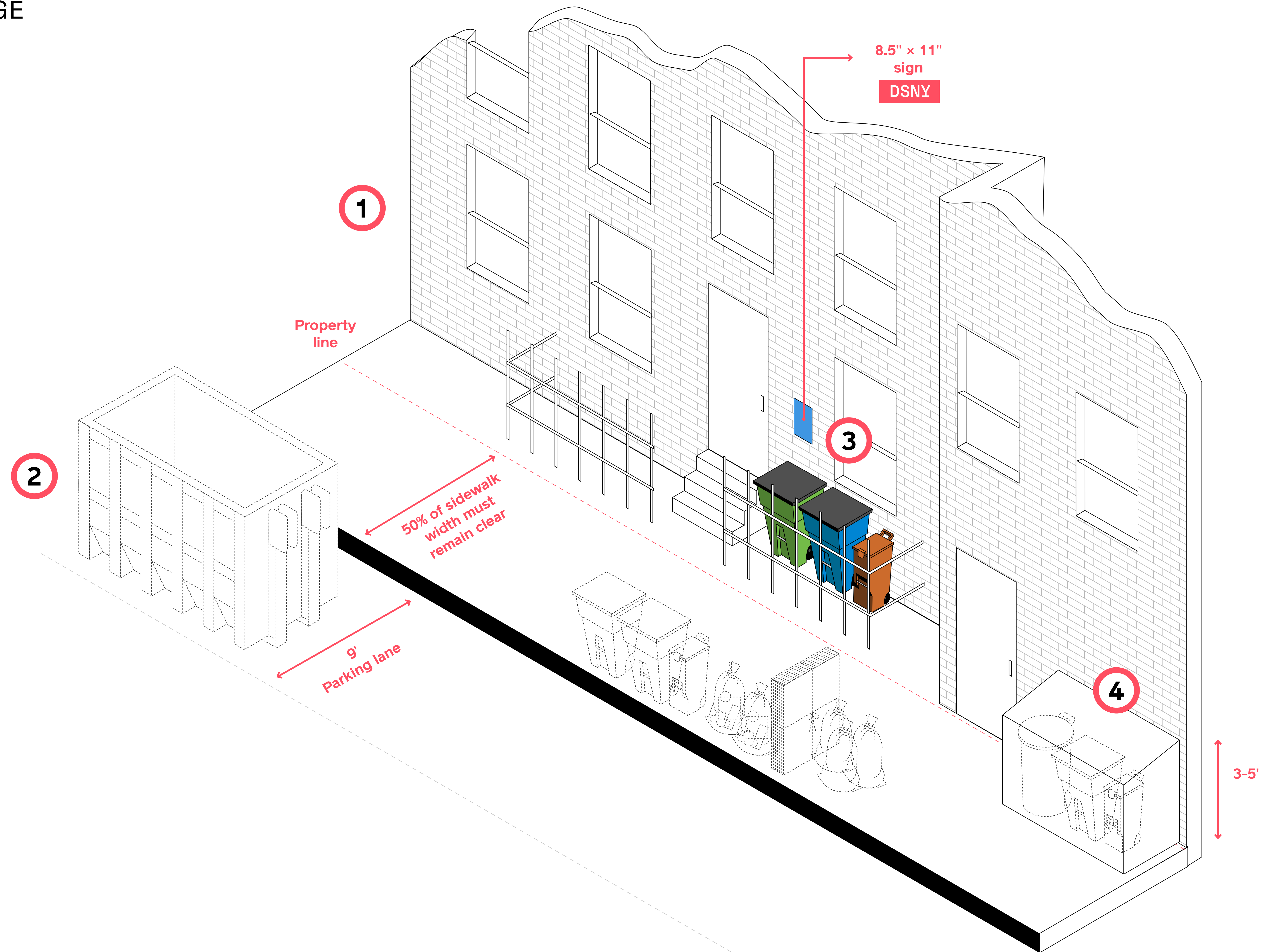

Rules vary depending on zoning, land use and particular neighborhood features. DSNY requirements differ from what a private carter may specify, so options for commercial properties are not necessarily the same as those for residential buildings. (See [NYC Rules for Setout and Exterior Storage Infographics](#) and [Agency Roles](#) for an overview.) Collection strategies will depend on the characteristics of the storage space available within the building property. (See [Chapter 2](#) for rules.)

Recommendations

Given the specific circumstances of each building and public space, buildings should use the collection strategy that allows for the most efficient transfer from storage area to truck. (For DSNY options, see [Chapter 2 on DSNY rules](#).) On the street, containers reduce litter, drips, odors and rats, and other nuisances associated with piles of bags. They also allow for automated collection, which can reduce worker injuries and the time and costs of collection,⁹ as well as collection frequency.

Containers, already required for organics, are also suitable for collecting textiles and e-waste. Therefore, when possible, use containers, preferably with compaction. For businesses, small wheeled bins could be the default solution when larger containers are not practicable.¹⁰ (See [Chapter 2, BPS 2.04](#), for a discussion of how to plan for containers inside buildings and in the streetscape directly in front of individual buildings.) When there is no space inside existing buildings or on sidewalks, it may be possible to share storage with neighboring properties or aggregate material at a neighborhood scale with a centralized facility. The best practice strategies discussed in this chapter focus

AGENCY RESPONSIBILITIES

		DSNY	DOT	DCP	DOB	FDNY
Operations	Type and size of container collected	x				
	Waste streams collected	x				
	Collection frequency	x				
	Setout and pickup time	x				
	Storage capacity	x		x		
	Collection strategy	x				
	Receptacles for pedestrian litter	x	x	x		
	Collection enforcement	x				
Land use	Storage area size			x	x	
	Storage area location			x	x	
	Storage area construction			x	x	x
	Storage area concealment			x	x	
	Sidewalk/street waste storage		x	x		
	Coordination with streetscape design		x	x		
Transportation	Truck access requirements	x	x	x		
	Coordination with parking	x	x			
	Coordination with traffic policies		x			
	Coordination with FDNY access		x		x	x

on using the collective resources of a block or neighborhood to introduce containerization, improve collection efficiency and support zero waste initiatives. Master plans for new and existing large-scale developments should also consider aggregated collection.

Truck Collection Typologies

The sort of container chosen for collection will depend on the volume of waste, the accessibility and size of the storage area, and vehicle-access options. Truck collection typologies are generally the same for door-to-door and aggregated collections except that aggregated collection also involves moving material between individual buildings and the shared collection point.

TRUCK COLLECTION TYPOLOGIES

1. Bags on Street

1

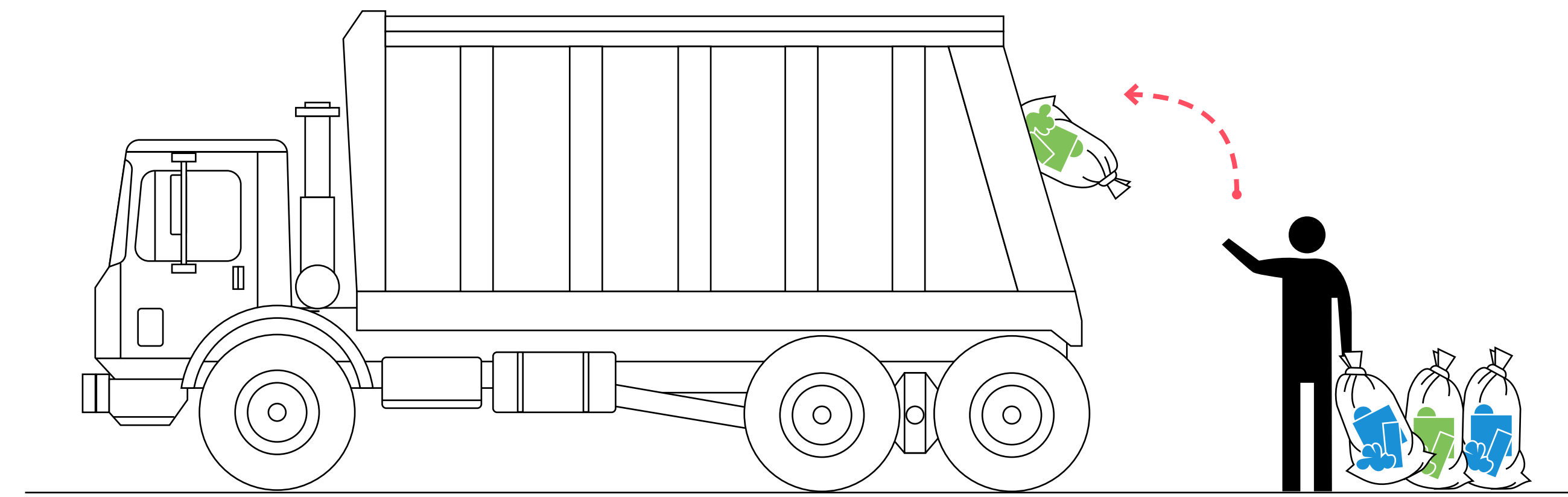

2. Wheeled Bins on Street

2

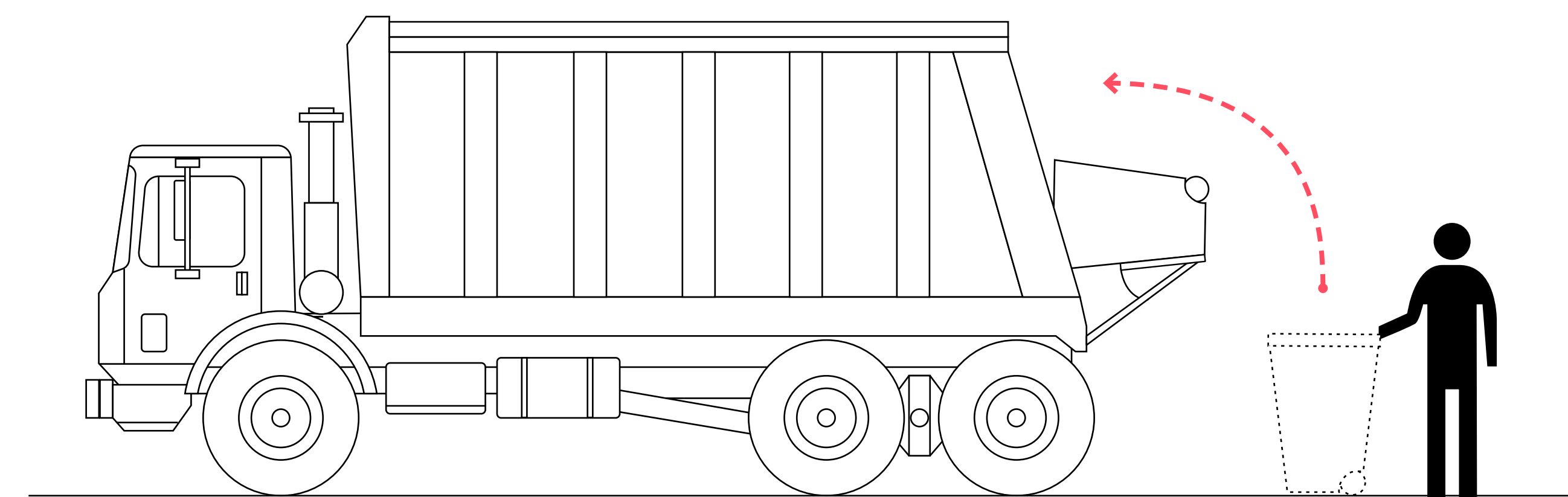

3. 1-8 Cu Yd Containers

3

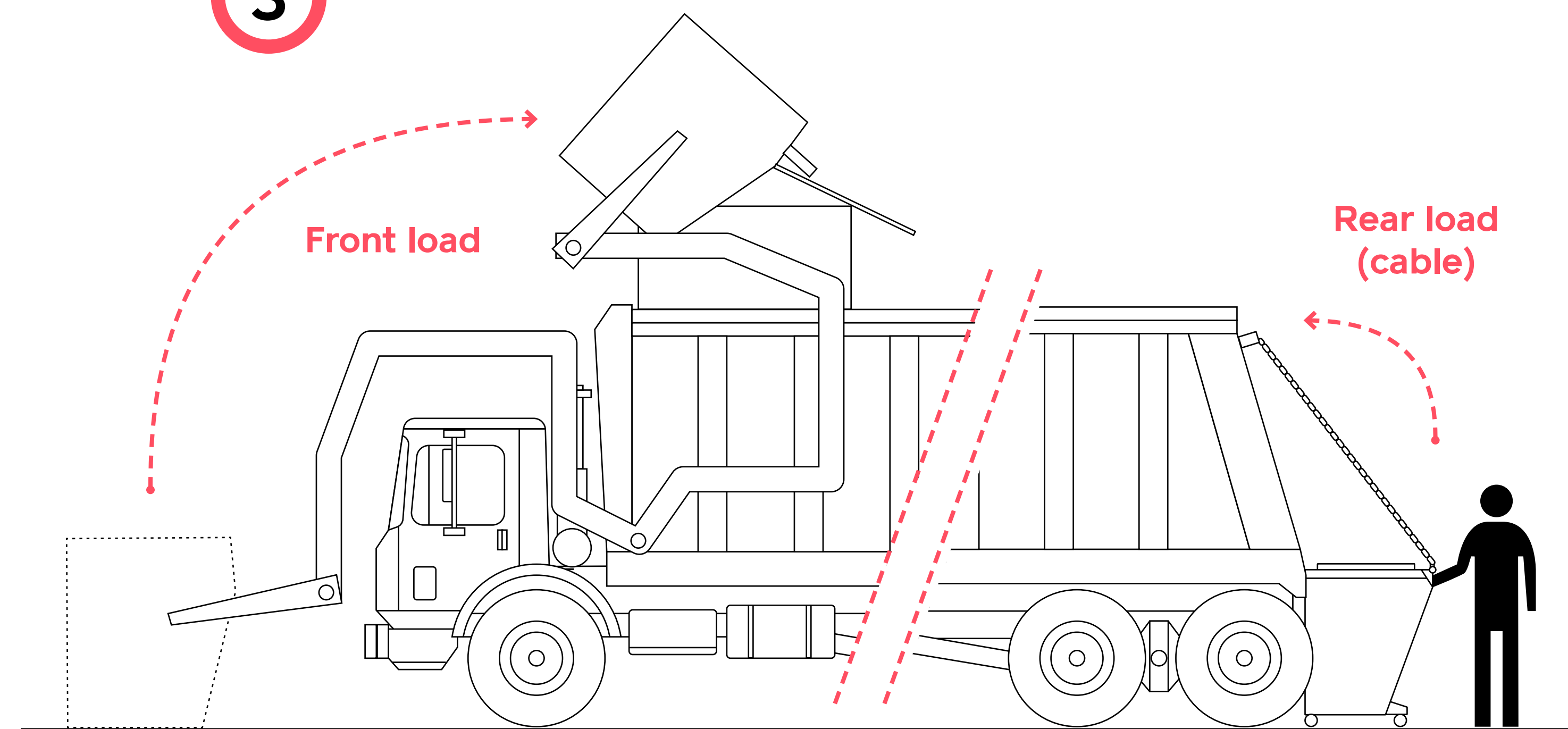

4. 20-40 Cu Yd (RoRo) Containers

4

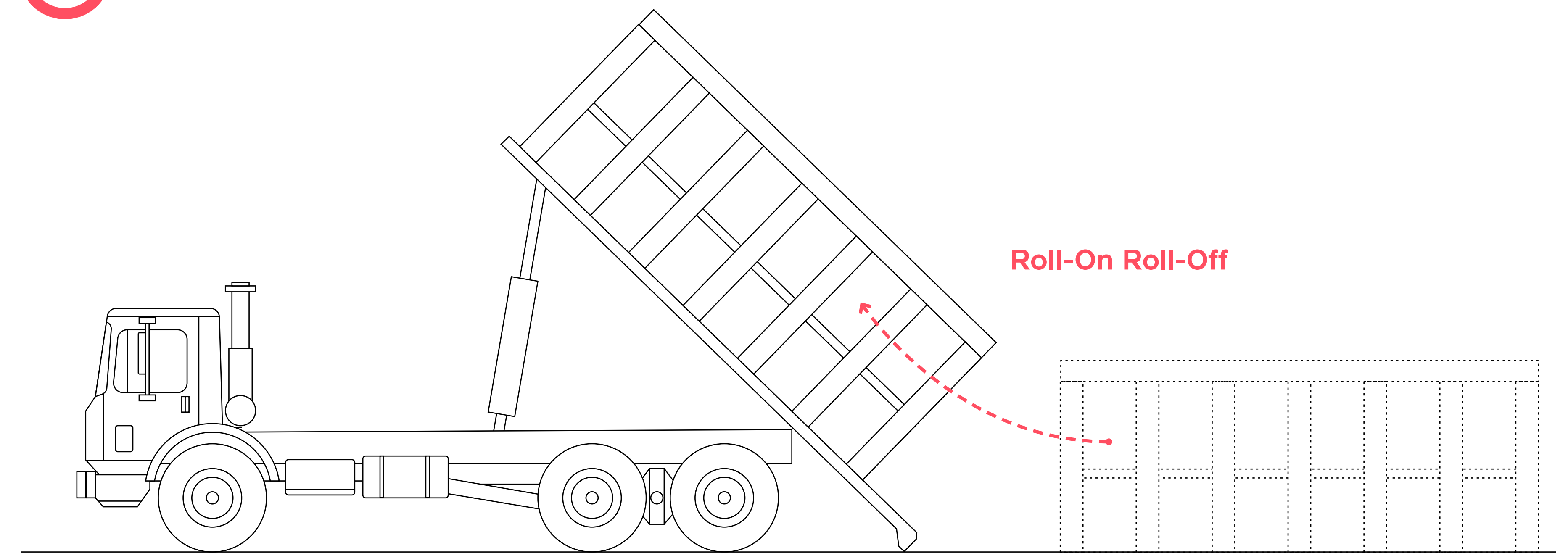

Note: Other equipment such as side arms and hoists not shown

TYOLOGY 1: BAGS ON STREET

The dominant strategy for door-to-door collection in NYC is to bring bags from a storage area and pile them on the curb.



Bags set out on the street in Downtown Brooklyn

Advantages

- There's no need for elevator or ramped access between the basement (or other storage areas) and the street because bags can be carried upstairs.
- Flexibility: Storage space doesn't have to accommodate the specific dimensions of containers, and bags can be piled to fill the available space.
- The absence of containers means that there is no maintenance, storage or inside return required after pickup.
- Bags can be carried between parked cars to a truck.¹¹

Disadvantages

- When set directly on the curb, bags can be torn open by rats and other pests.¹² (For this and other reasons, organics are not collected in bags.)
- Unsightly piles of bags impinge on public space and often leave litter, liquids and odors on the sidewalk after collection.
- Piling bags on the curb and carrying and throwing them from curb to truck is time-intensive and physically demanding; it can also be a significant source of injuries such as strains and sprains.¹³
- Bags can neither weigh more than 50 lbs, per OSHA rules, nor be used with automated or semi-automated collection trucks. (See [Rules in Chapter 2.](#))
- Bags are breakable, thus potentially dangerous to building staff and sanitation crews when sharp or toxic materials are present.

TPOLOGY 2: WHEELED BINS ON STREET

Wheeled bins are heavy-duty plastic carts with two to four wheels. They are compact and easy to maneuver yet have limited capacity—up to 96 gal. or 0.25 cu yd. In NYC, wheeled bins are used for organics collection, for storage and setout from smaller buildings and in low-density neighborhoods where buildings have ample storage and curb access relative to the volume of waste generated.

Although they are compatible with automated collection, DSNY currently empties bins manually into trucks. For DSNY collection, bins typically lack wheels and must be 44 gal. for trash and 32 gal. for recyclables. Wheeled organics bins provided by DSNY are 13, 21 or 32 gal., to allow for manual lifting.

Advantages

- Waste is protected from rats and pests.¹⁴
- Material is protected from rain and snow.
- Workers are protected from dangerous contents and unsafe load weights.
- Wheeled bins, which are compatible with automated and semi-automated collection trucks, can be heavier than the weight safe for manual lifting.¹⁵
- Bins can be tracked, allowing for easy implementation of unit pricing/SAYT.
- Bags are optional; materials can be placed directly in the bin.
- Bins can reduce waste handling.

Disadvantages

- The storage area must accommodate bin maneuvering and have a clear path by elevator/ramp to the curb.
- At the curb, adequate space is needed to roll the bin to the truck.
- Wheeled bins must be returned to the storage area.
- Bins require cleaning and can be damaged.



Bins for trash, recycling and organics are emptied manually into rear-load trucks.

TPOLOGY 3: 1-8 CU YD CONTAINERS

Front-end load (FEL) or rear-end load (REL) containers are steel or plastic carts with lids. Containers under 3 cu yd are wheeled to the curb; larger containers are emptied directly from the loading dock or courtyard where they are stored. Containers can be submerged underground and emptied into trucks with cranes.

Advantages

- See wheeled bin advantages on typology 2.
- Increased capacity can reduce collection frequency relative to that for wheeled bins and bags.
- Metal containers can be fitted with a compactor to increase capacity.
- The containers can be connected directly to chutes.

Disadvantages

- See wheeled bin disadvantages.
- Container loading is more involved and truck clearances are required.
- Collection can be noisy.



FEL with wheels and without wheels emptied by DSNY, REL emptied by commercial hauler

TYPOLGY 4: 20-40 CU YD (RORO) CONTAINERS

The 20–40 cu yd containers are loaded directly from the compactor yard or loading dock onto the flatbed of the collection truck. Containers can be open-top (for construction debris or recyclables) or fully enclosed and fitted with a self-contained or separate compactor. Each container collection requires a dedicated trip in which the container is loaded onto the truck, driven to the transfer facility, dumped and returned.¹⁶ Containers are used by large commercial, mixed-use and institutional buildings and also for aggregated collection.¹⁷



Roll off truck pulling a compactor from a loading dock

Advantages

- Compactor containers have higher capacity than a rear-load compactor truck.
- Compactor containers require the fewest truck miles and labor hours per ton.
- Can be connected directly to chutes.
- Can incorporate compaction.
- Self-contained compactors are sealed.
- Compactor containers are difficult to overload or close improperly.¹⁸

Disadvantages

- See 1–8-cu yd container disadvantages on typology 3.
- Equipment is expensive and requires some training to operate and a maintenance routine; DSNY also requires insurance.
- A curb cut is needed for truck access.
- A truck-accessible storage area with sufficient head height and space for truck maneuvering is required.
- Waste aggregated while the container is off-site for collection needs to be stored.
- If the containers are not self-contained or if waste accumulates too slowly, containers may be emptied when only partially full for odor-control reasons, reducing efficiency.
- Collection can be noisy.

20-40 CU YD CONTAINERS AND 1-8 CU YD CONTAINERS

SIZE	TYPICAL DIMENSIONS			FOOTPRINT
	LENGTH	WIDTH	HEIGHT	
1 cu yd	6'	2'6"	2'6"	15 SF
2 cu yd	6'	3'	3'6"	18 SF
3 cu yd	6'	4'	4'	24 SF
4 cu yd	6'	5'6"	5'	33 SF
6 cu yd	6'	6'	5'	36 SF
8 cu yd	6'	6'	7'	36 SF
35 cu yd compactor container (DSNY)	23'	8'4"	8'8"	191 SF

All can be loaded with gravity chute, hopper, or cart tipper attachment.
For clearances, other sizes and types refer to DSNY or manufacturer recommendations.

1-8 cu yd containers

- Used for storage and set out
- 3-8 cu yd do not have wheels
- For C+D waste 0.5 cu yd 'minis' to 2 cu yd are generally used

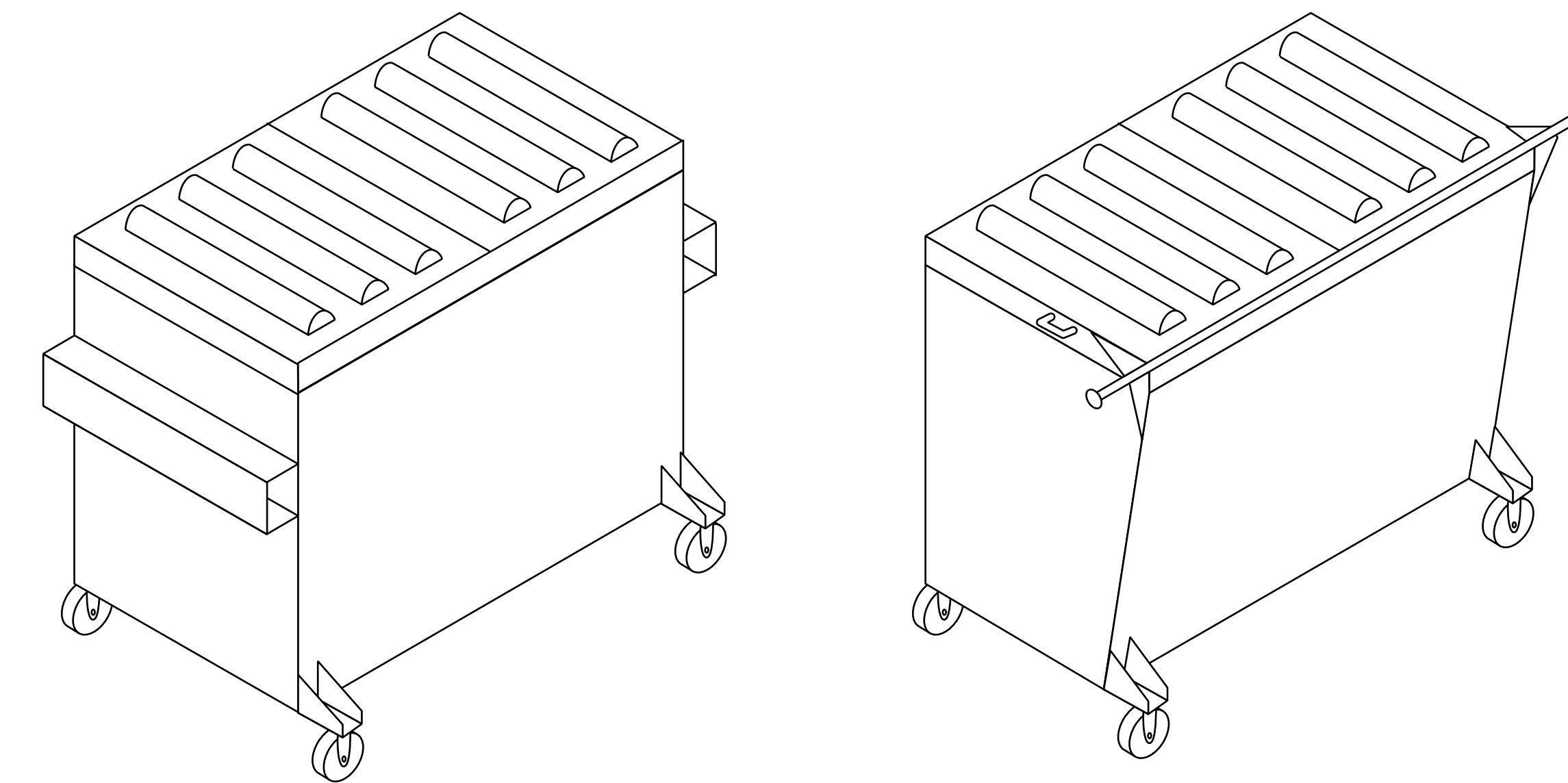

Compactor Containers

- May be self-contained or stationary

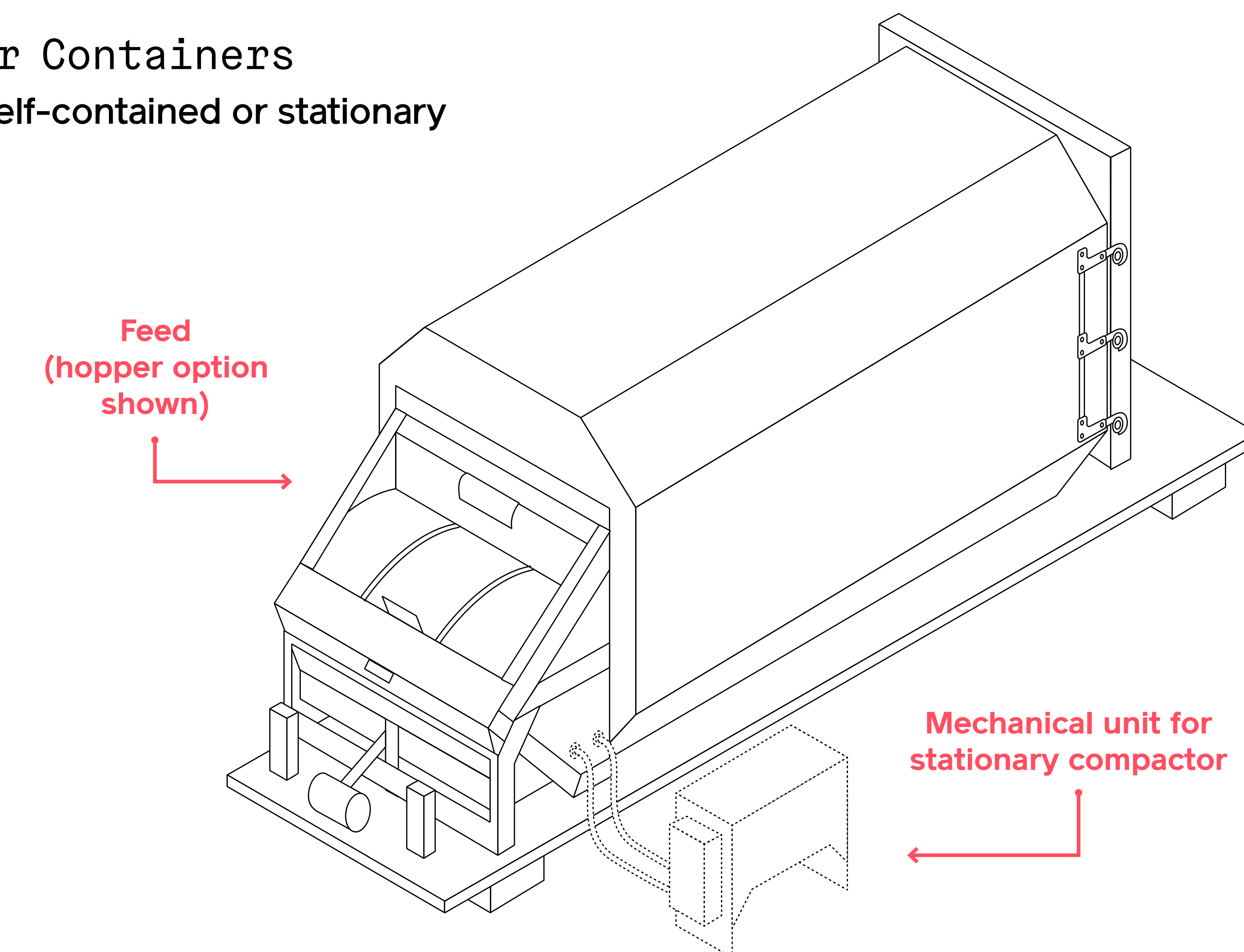

Collection & Urban Design

Best Practice Strategies

Compactor container being loaded onto a roll off truck. Where possible, consolidating waste in compactor containers at the building or neighborhood scale will reduce the impacts of truck collection in the community and citywide.



Thousands of tons of discarded materials pass through New York City buildings, across sidewalks and into collection trucks, day and night. The best practices listed below describe how efficient transfer of these materials can be incorporated into land use planning, street design and community development. While many of the strategies are not applicable to architects designing a single building, they are applicable for many of the larger developments currently going up around the city. These strategies may encourage developers to look across their portfolio of properties and propose new solutions as an amenity to residents and staff. Building managers and business improvement districts (BIDs) can use them to develop new arrangements that support their neighborhoods.

These strategies describe how communities can manage material flows through a distributed network of hubs to reduce local impacts of collection and increase the resiliency of the system as a whole. While these alternative modes of collection are relatively rare in NYC and there are significant logistical challenges to solve, with the political will, and collaboration between public and private stakeholders, the process could be accelerated. In the last decade, NYC revamped its streets and public spaces to be safer and greener, with more trees, public plazas and bike lanes. (See [DOT's Street Design Manual](#).) Further redesign would allow the city to better manage the increasing material flows that accompany increasing density.

Also, for much of our existing building stock, the only good solutions involve consolidation within other buildings and public spaces. For existing neighborhoods, the process will need to be iterative

and done in collaboration with local stakeholders and communities—as in the [public plaza program](#)—with an array of pilot projects that are evaluated, improved upon and developed in other locations. For larger new developments, standards and incentives could require or encourage private developers to employ these strategies that benefit the city as a whole.



Manhattan intersection redesigned to include pedestrians and cyclists

Neighborhood-Scale Collection

Door-to-door collection, or collection by individual businesses within a building, maximizes the number of truck stops, trips and miles. Anytime waste and recyclables can be aggregated between buildings (or between businesses within a building) via pushcarts, small electric vehicles or pneumatic tube, truck miles are avoided, along with the attendant economic, environmental and public health costs.¹⁹ The efficiencies thus achieved can be used to divert more materials from landfills with lower net costs and impacts. Neighboring buildings, along with local organizations such as BIDs providing sanitation services, could coordinate their waste collection by sharing containers at central collection points.

Individual Building Considerations

- Equipment for moving waste to central location
- Coordination between building managers and system operator

Planning Considerations

- Location of centralized facility relative to individual buildings
- Number of streams managed in centralized location
- Network infrastructure, if applicable
- Responsibility for operations and maintenance
- Administrative structure for system management, if multiple stakeholders
- Communication strategy
- Shared costs

3.01 PROVIDE LOADING AREA AT BASE OF A BUILDING THAT CAN ALSO BE USED BY OTHER BUILDINGS

Building staff from neighborhood buildings cart material to one of several single-bay loading areas once a day. (See [Battery Park City case study](#).)

Considerations

- Siting and location of compactors
- Timing of access to compactor and staffing
- Number of streams managed



Building staff consolidating waste at a shared collection point



3.02 PROVIDE CENTRAL COLLECTION FACILITY WITH MULTIPLE COMPACTOR CONTAINERS SHARED BETWEEN BUILDINGS

A dedicated collection truck and crew collects material from all buildings in a development and transports it to compactors in a central facility several times per week. (See [StuyTown case study](#).)

Considerations

- The type of collection truck (rear-load compactor, pickup or box) will depend on the volume of material and whether the truck also used for auxiliary waste storage, or other tasks in the development.
- Consider low- and zero-emission vehicles and cargo bikes.
- Coordinate routes with collection from litter bins on the property.



3.03 PROVIDE A SYSTEM OF PNEUMATIC TUBES CONNECTING BUILDINGS TO A CENTRAL TERMINAL

Pneumatic tube networks have been used for trash collection in dense residential developments since the early 1960s, when the first systems were installed in Sweden. Since then, they've been incorporated into urban mixed-use urban renewal projects in historic city centers and other sites where truck access is limited, as well as in mega developments in Asia and the Middle East. In the U.S., the only municipally operated system is on NYC's Roosevelt Island.

In lieu of collection trucks, a pneumatic tube connected to individual buildings can convey separate waste fractions (refuse, recyclables, organics) through a common trunk line to a central collection terminal by pulsing the fractions at different time intervals. The pneumatic

Central facility StuyTown; Exterior yard at Morningside Gardens

connections for individual buildings are either in chutes on individual floors or are inlets on the ground floor or building exterior. Typically, material is transported from these inlets to the collection terminal three to five times a day.

The availability of automatic collection 24 hours a day, 7 days a week minimizes space and labor requirements for individual buildings while providing a range of other public and private advantages because of the elimination of collection trucks, storage and staging of bags or containers at the curb and potential disruptions to collection due to weather or other events. At the collection terminal, the separate streams are compacted into containers for transport to the processing or disposal facility for each material type. (See [Roosevelt Island](#) and [Vitry-sur-Seine](#) case studies.)

Input Types

- Gravity chutes
- Inlets in lobby
- Inlets in courtyard or street
- Input by building staff or residents
- Addition of pedestrian litter bins
- Separate inputs for commercial and residential users with keyed access for billing and SAYT

Considerations

- The cost of laying pipe is reduced when it's installed with other utilities like gas and water.
- Design the system layout to maximize energy efficiency, including caps on electricity use in procurement specifications and contract documents.
- For maximum benefit, work with stakeholders and relevant agencies



Above:
Compactor container fed by pneumatic tube

Left:
Map of pneumatic pipe network at Clichy-Batignolles (collection terminal is at far left)

to ensure all waste that can be managed by the system is collected by it.

- When possible, locate pipe in a utility corridor to facilitate long-term access for maintenance, repair and reconfiguration.²¹

3.04 PROVIDE A SYSTEM OF PNEUMATIC TUBES CONNECTING SHARED INPUTS TO A CENTRAL FACILITY

Rather than sharing loading docks for compactors emptied by truck, buildings could share pneumatically collected containers. This aggregated-inlet approach could lower the barriers for retrofitting pneumatic networks in existing neighborhoods and significantly increase the capacity and public benefits of individual networks. Some benefits of traditional pneumatic collection for individual buildings are lost: Labor is required to move material to the shared input point and storage is required inside the building, as well as all storage requirements for material handled by the system. But this hybrid approach can still increase collection frequency for waste and recyclables from several times a week to every day and offer service during holidays and extreme weather events. Because drop-off points wouldn't have to accommodate container loading and container does not have to be at street level, inlets could be co-located with distribution of inbound deliveries or community drop-off for other materials. Material is transported from the aggregated inlets to the pneumatic terminal two times a day. (See [High Line Corridor case study](#).)

Considerations

- See BPS 3.01 considerations for shared loading area.
- See BPS 3.03 considerations for pneumatic network.



Pneumatic inlets shared by multiple buildings can be inset into a wall or freestanding on a street corner.



In Barcelona, residents and small businesses bring recycling to shared surface containers (right) and trash and organic waste to pneumatic inlets (left).

Access to Efficient Collection and Recycling as a Public Amenity

In many NYC neighborhoods, commuters head to work by walking to subway stations rather than driving from their garages. With the advent of Citi Bike, many bike commuters are walking several blocks to a bike dock instead of hassling with storing their personal bikes in small apartments. Well-designed drop-off collection points on street corners and public plazas could address inadequate storage in individual buildings. (See [Paris Trilib' case study](#).)

Planning Considerations

- Size and location collection equipment
- Number of streams co-located
- Space required
- Maximum distance from users
- Coordinate with street design (public realm) and open-space planning (private property)
- Utilities (when siting underground containers and tubes)
- Truck access

Operational Considerations

- Maintenance and security (similar to other street furniture)
- Communication and outreach to public

3.05 PROVIDE SHARED SURFACE CONTAINERS IN THE PUBLIC REALM OR ON PUBLIC AGENCY PROPERTY

These could be wheeled bins or crane-hoisted 1–8 cu yd containers, commonly used in European cities. They can be used by building staff for aggregated collection for multiple buildings or businesses, with lockable inlets that restrict use to known generators and allow SAYT billing. Or they can be used for pedestrian drop-offs of low-volume fractions, such as textiles or e-waste, to provide convenient local access to such source-separated materials while minimizing collection costs and impacts. Well-designed and -maintained facilities of this sort are a neighborhood amenity. (See [Paris Trilib' case study](#).)

Considerations

- Size and capacity of containers versus collection frequency
- Design of containers or container enclosure
- Sufficient curb space
- Siting and distance from users (particularly in front of residential buildings)
- Responsibility for maintenance
- Directly truck accessible, or wheeled bin within an enclosure
- Whether the trucks/equipment configurations needed to collect such containers are compatible with the attachment of snowplow equipment²²

3.06 SHARED SUBMERGED CONTAINERS IN THE PUBLIC REALM OR ON PUBLIC-AGENCY PROPERTY

The same types of containers that are placed on the curb can be buried in an underground vault with only a small inlet above the surface. Containers can be raised on a lift and wheeled to a truck, or lifted out and emptied by a collection truck with an attached crane. Submerged containers offer the advantage of minimal intrusion on the curb relative to surface containers of the same size. First used in European cities, submerged containers are now used in several Canadian cities and were recently installed in Kissimmee, Florida, to provide aggregated collection for business and municipal waste and recyclables. Hoist cranes can be retrofitted onto a conventional truck chassis. (See [The Hague case study](#).)



In Kissimmee, Florida, the first US city to install submerged containers, a standard collection truck modified with a hoist that can be used with both submerged and surface containers

Considerations

- Increased cost compared to surface containers
- Coordinate with existing conditions of site, including underground services, overhead clearances and adjacent land uses
- Vault is the most expensive part, consider planning space for future containers/streams
- Truck access for emptying container
- Security during emptying
- Responsibility for maintenance
- Keyed inlets for SAYT tracking
- For DSNY collection, issue of equipment compatibility with snow removal, as discussed above

3.07 STAFFED DROP-OFF LOCATIONS

Drop-offs can be sited at locations with convenient, high-volume pedestrian access points, such as organics drop-offs at subway stations or Greenmarkets. (See [GrowNYC](#), [Punt Verd](#) and [Ménilmontant](#) case studies.)

Considerations

- Coordination with other collection options
- Siting
- Fixed location or mobile
- Timing
- Outreach
- Collection streams

- Community partnerships
- Responsibility for maintenance
- For DSNY collection, issue of equipment compatibility with snow removal, as discussed above

Integrated Planning

The use of our streets changes over time with shifts in modes of transportation, freight distribution systems, technologies for supplying power and information, and activity patterns. And our streets and public spaces need to meet many needs within constricted boundaries. Construction and maintenance operations—such as surface paving and utility and sewer installation and repair—need to be coordinated, as do the physical design and placement of features such as intersections, curb extensions and street furniture. Compared to the movements of people and goods, the flows of water, sewage, gas, electricity and information; the public safety requirements of firefighting, policing and emergency medical services; the provision of plantings, signage and other visual and environmental features—and especially, the use of curb space for parking—the predictable and inevitable outbound movement of wastes and recyclables seems to be the subject of afterthought rather than planning. This needs to change. The collection of waste and recyclables needs to be integrated into this overall public space planning context.

3.08 DESIGN STREETSCAPES THAT ALLOW CURBSIDE ACCESS TO CONTAINERS

New York is increasingly anomalous in the developed world, in that the use of automated and/or aggregated collection of containerized waste and recyclables is relatively rare.²³ A major reason for this is that lines of parked cars prevent access between materials placed at the curb and automated collection trucks. Our streets—and their uses—could be modified to accommodate this smoother, less costly, less polluting form of collection. Flexible street design could allow collection on certain days and uses such as loading or parking on other days. While beyond the scope of this guide, such changes could also accommodate many other desirable objectives, ranging from traffic calming and runoff control to social spaces and street greening. (See [BPS 2.04](#) and [Chapter 4](#). Also see [Paris Trilib’ case study](#).)

3.09 INCORPORATE COMMUNITY INTO COLLECTION OPERATIONS

Designers can support conventional outreach and education efforts by finding ways to dignify the act of properly discarding material and making waste flows visible, not as a crisis, but as a source of pride. Substituting thoughtfully designed combinations of public and private space containers and collection systems for the amorphous piles of bags that currently line our curbs should bring us closer to this goal. Increasing the degree of social interaction around waste management activities—and peer awareness of neighbors’ behavior—can lead to a higher degree of source separation, better compliance with recycling regulations and a greater concern for the public space equipment used at drop-off points. (See [The Hague case study](#), [GrowNYC case study](#), and [High Line Corridor case study](#).)

Considerations

- Availability of metrics
- RFID or other technology for associating deposit volumes with individual users
- Adopt-a-container programs to encourage neighbors to keep bins emptied and clean
- Volunteer waste ambassadors who can share information and generate support
- Mentorship for building staff, residents and businesses



When Plaza Lesseps was built in Barcelona, a pneumatic terminal was inserted under the new plaza to serve the neighborhood; the angular streetlighting is also the stacks for the pneumatic terminal.

BEST PRACTICE (SHARED) COLLECTION CONSIDERATIONS

Surface containers

- Least costly and most flexible
- Storage capacity is limited, increasing collection frequency
- Truck access is required

Submerged containers

- More costly and require coordination with below surface conditions
- Free up space at surface
- Truck access is required

Pneumatic networks

- Most costly
- Requires coordination with below surface conditions along entire tube path as well as construction of a collection station
- Capacity is highest because inlets may be emptied multiple times in a day
- No truck access needed, except at collection station

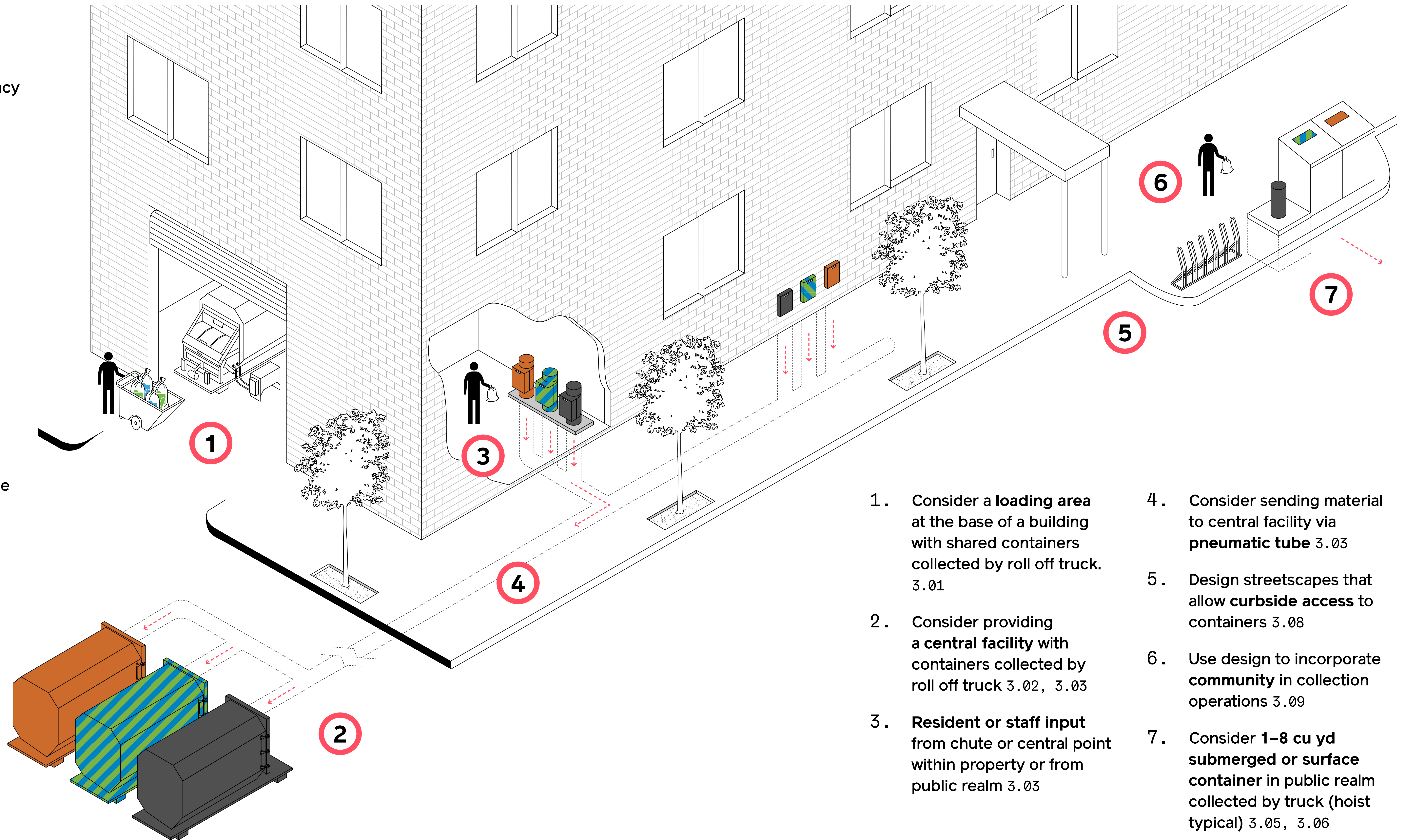

1. Consider a **loading area** at the base of a building with shared containers collected by roll off truck. 3.01
2. Consider providing a **central facility** with containers collected by roll off truck 3.02, 3.03
3. **Resident or staff input** from chute or central point within property or from public realm 3.03
4. Consider sending material to central facility via **pneumatic tube** 3.03
5. Design streetscapes that allow **curbside access** to containers 3.08
6. Use design to incorporate **community** in collection operations 3.09
7. Consider **1–8 cu yd submerged or surface container** in public realm collected by truck (hoist typical) 3.05, 3.06

Collection & Urban Design Case Studies

Detail of submerged container location map produced by the Municipality of the Hague with containers indicated in red, see case study. Shared containers can improve collection in neighborhoods where existing buildings lack adequate space.

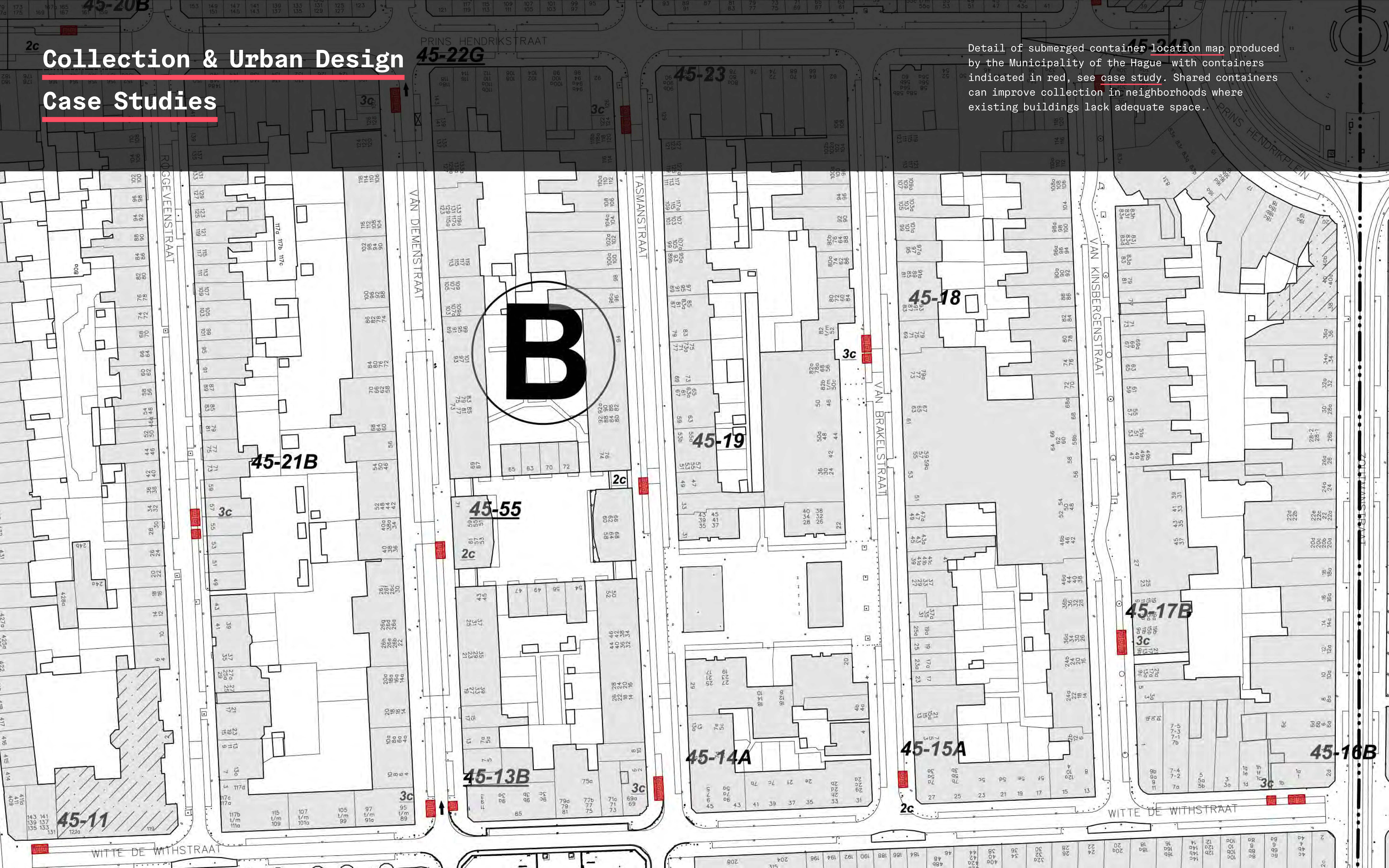

Battery Park City, NYC

Type

Shared compactor

Best Practice Strategies

- 3.01 Provide loading area at base of a building that can also be used by other buildings
- 3.09 Incorporate community into collection operations

Summary

The planned high-rise community of Battery Park City is home to 14,000 residents, office buildings and public parks along the Hudson River at the southern tip of Manhattan.²⁴ The Battery Park City Authority (BPCA) leases land to developers whose buildings must meet special requirements for design, sustainability and community amenities.²⁵

In 2006, construction of the new World Trade Center site led to an explosion in the rat population. The BPCA responded by amending the neighborhood plan to include several shared loading areas equipped with 35 cu yd compactor containers. Just as building developers were required to provide open space, schools and other amenities, developers of specified sites were required to host compactor containers managed by the Battery Park City Authority. Instead of piling bags of refuse on the sidewalk two days a week for pickup the next morning, porters could now deliver bags to a shared compactor each day. Instead of a compactor truck stopping to load bags from every



Building staff bringing waste in tilt trucks to shared compactor managed by The Battery Park City Authority

school and residential building in the neighborhood, roll-on/roll-off trucks collect compacted containers from just four locations.

Compactors can hold 150 carts' worth of material.²⁶ Each compactor manages material from about 2,000 units and takes about 90 minutes to load each day. Not only has the strategy addressed the rat issue, but it has also been popular with porters.²⁷

Challenges

In Battery Park City shared compactor containers are used only for refuse. Metal, glass, plastic, paper and cardboard are still collected door-to-door with rear-load compactors, as are organics from buildings that participate in the city's organics-collection pilot. Additional loading area space—or separate time windows allocated to each waste fraction—would be required in order to include these source-separated streams in the consolidated-collection system.

The fact that BPCA controls leasing arrangements for the entire development facilitated the shift from door-to-door pick up to consolidated collection. The fact that new developments were in the planning stages made it convenient to install curb cuts in locations that would provide truck access to the shared compactors. Shifting to shared loading docks in existing neighborhoods with multiple private parcel-owners would require coordination between property owners to achieve these ends.



Building staff transporting waste down the street, loading tilt truck into tipper, BPCA staff emptying tilt truck into compactor

Roosevelt Island, NYC

Type

Pneumatic collection

Best Practice Strategies

- 3.03 Provide a system of pneumatic tubes connecting buildings to a central terminal

Summary

Roosevelt Island is a planned community of 14,000 in the East River, between Manhattan and Queens. The 1969 master plan by Philip Johnson and John Burgee envisioned a full-service community without cars.²⁸ Tasked with finding a way to remove trash without trucks, engineers installed a pneumatic tube network—the first such system for municipal solid waste in the United States. Trash chutes in the island's 16 residential complexes are connected via pneumatic tube to a terminal at the island's north end. Several times a day, turbines at the collection station are turned on, generating a vacuum. Valves at the bottom of the chutes are opened and trash flows at 50 mph to the terminal, where it is compacted into containers and collected by roll-on/roll-off trucks.

The system, which has been in continuous operation since the first residents arrived in 1975, has been expanded three times to accommodate new development. The island is managed by the Roosevelt Island Operating Corporation (RIOC), a public benefit corporation of New York State. All developers who lease land

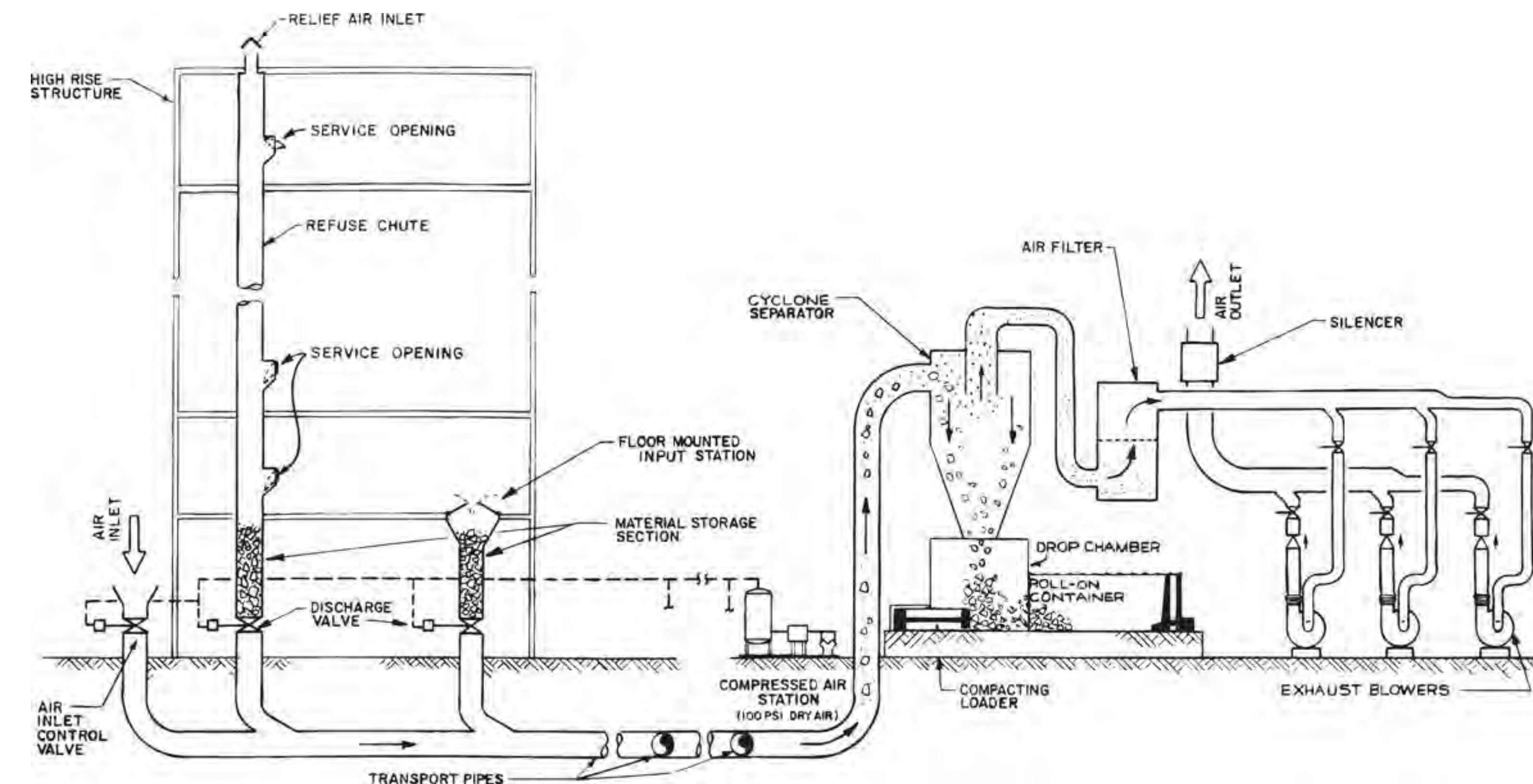

Residential trash from all buildings, except the Cornell Tech campus, is collected by pneumatic tube; Operations diagram by Gibbs and Hill engineers showing how waste flows from chutes in individual buildings through a pneumatic tube to a shared compactor container, 1971

from RIOC must connect their buildings to the pneumatic network. As a result, building porters on the island do not manage refuse, and buildings do not provide storage areas for waste. Residents often become aware of the network only on the rare occasions that the system is shut down and bags are piled on the curb, as they are in most New York City neighborhoods. Because collection occurs off the street and without trucks, Roosevelt Island was the sole neighborhood in the city whose DSNY service continued during Hurricane Sandy and the blizzard of 2012.

Challenges

Because the system was built before curbside recycling was required, recycling is not managed by the system. Newer systems incorporate multiple fractions. (See [Vitry-sur-Seine case study](#).)

The Roosevelt Island network also does not collect refuse from businesses, because they must contract with private carters.

As a result, the system does not run at full capacity.



A valve in the building cellar at the base of a gravity chute connects to the pneumatic tube below; View inside the terminal (pneumatic tubes are painted red) including container moving equipment for 30 cu yd containers

Vitry-sur-Seine, France

Type

Pneumatic collection

Best Practice Strategies

- 3.03 Provide a system of pneumatic tubes to connect buildings to a central terminal

Summary

Vitry-sur-Seine is a diverse city of 90,000 outside Paris where 75% of residents live in apartment buildings, a third of which is public housing. In 2008, as the city embarked on a major urban renewal project to improve conditions in several of its public housing estates and to develop an interurban tramline, Vitry was also revisiting its waste management plan; it was looking for ways to encourage recycling and reduce the noise and traffic congestion associated with waste collection. After touring Barcelona's pneumatic networks, the mayor requested that a study of tube collection be done for the renewal project, with the possibility of connecting other neighborhoods in a later phase.²⁹

The first-phase of the system, which will serve an eventual 10,000 apartments, began operation in 2015 and now serves 1,200 apartments, small businesses and a school.³⁰ Most of the 60 input points activated so far are adjacent to building entrances. (Residential inlets are located outside buildings but on private property, to encourage residents and building managers to take ownership of the inlets and reduce



Above:
Residents depositing household waste in an inlet on the sidewalk

Left:
View inside pneumatic terminal, containers are loaded several stories below grade and lifted up to a loading dock with a bridge crane

maintenance issues.) Vitry’s system currently collects two streams—mixed recycling and refuse—but was designed to allow for a potential third stream: organics. (Glass and bulk items are collected separately.)

The terminal sits on narrow parcel between two streets. In order to have enough room for trucks to load inside the small facility, containers are filled underground and raised with a crane bridge to a single street-level loading dock. Large picture windows allow passersby to see into the facility, with the tubes and turbines of its otherwise invisible network.

Some funding for the 32 million euro pneumatic network came from the regional waste authority; the rest was financed by the city via a 5% increase in collection fees implemented over several years.³¹ Vitry launched its pneumatic system with a communications campaign that included home visits to 80% of the residents whom the new network would serve. A recent city survey showed the response from residents was overwhelmingly positive. Vitry’s project manager is pleased with the service but notes that the network has not improved separation of recyclables and that more education and outreach is necessary.

Challenges

- Vitry’s pipes were installed in existing streets and sidewalks. Inaccurate below surface survey data caused significant delays and cost increases as the pipes had to be rerouted.
- Contract negotiations were made more challenging by the fact that relatively few manufacturers submitted bids.

Applicability to NYC

New York City could take advantage of large-scale urban renewal and transit projects to install infrastructure that would reduce the impacts of truck collection. Surveys will be critical for any project taking place below city streets. (See [The Hague case study](#) on planning for existing conditions.)



City staff making home visits to explain how the new system works

Study of High Line Corridor Pneumatic Waste-Management Initiative, NYC

Type

Pneumatic collection, shared containers

Best Practice Strategies

- 3.04 Provide a system of pneumatic tubes connecting shared inputs to a central facility

Summary

The High Line viaduct was originally built to bring freight into West Chelsea factories by rail. It is now an iconic park surrounded by residential development and offices. Soon it could channel waste out of the neighborhood and directly onto railcars via pneumatic tube.

The High Line Corridor Pneumatic Waste-Management Initiative proposes a third chapter for the High Line in which building staff and cleaning crews from the local business improvement district cart waste to shared containers connected to a 1.5-mile long pneumatic tube attached to the underside of the High Line. Recyclables, organics and refuse would be pulsed at different times to a collection terminal at the north end of the High Line, compacted into shipping containers and sent by rail to processing and disposal facilities. Space beneath the shared containers could be used as micro-distribution centers

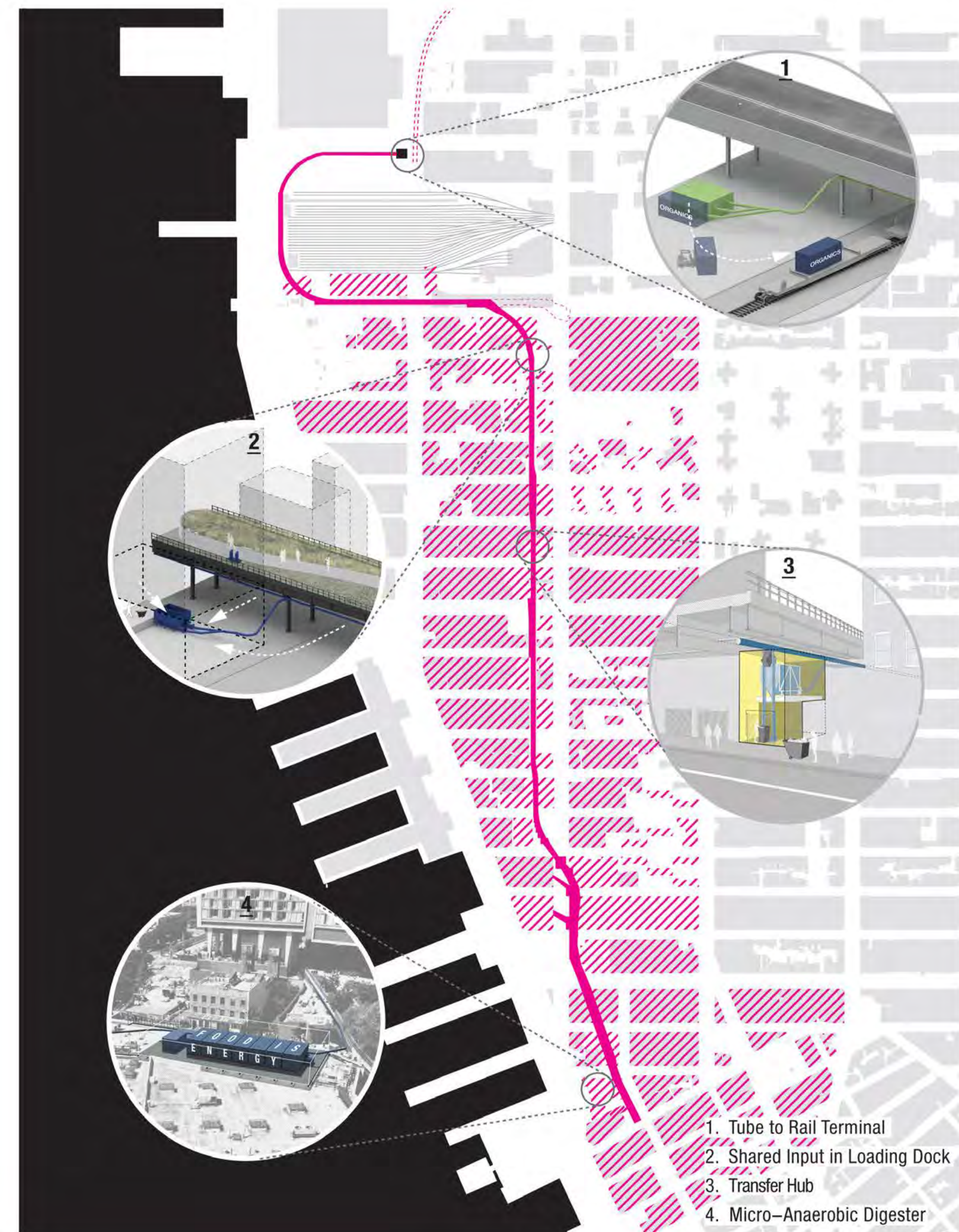

Overview of district-scale system and potential area it could serve

for local last-mile package delivery—or to host cardboard balers or drop-off bins for e-waste and textiles. These parking space-size transfer hubs, or shared utility closets, could be located anywhere within reach of the High Line viaduct, including in the loading docks of the large former-industrial buildings the High Line was built to serve. This concept could be replicated in neighborhoods along any of the city’s elevated-subway, rail or roadway viaducts, or shallow (cut-and-cover) subway lines. In addition to the primary trunk line for the three postconsumer streams, a smaller pneumatic tube could be affixed to the High Line to send food scraps from restaurants and food businesses along the corridor to micro-anaerobic digesters, to produce energy for local use.

The New York State Energy Research and Development Authority (NYSERDA) and New York State Department of Transportation have co-funded an effort led by ClosedLoops to advance project pre-planning from the preliminary feasibility/cost-benefit analysis stage (which is already completed) toward potential implementation. The goals of the current project phase are to identify structurally and operationally viable design solutions for installing pneumatic collection along the High Line; to determine optimal operating and ownership models for the shared infrastructure; and to develop the analyses of public and private costs and benefits that are necessary for project financing.³² The current initiative evolved through meetings and site visits with community groups, property owners and city agencies. If implemented, it could be a model for community engagement in planning for district-scale waste management.

Challenges

- Multi-stakeholder process involving many properties and city agencies
- Securing space for transfer hubs and collection station
- Business model and project financing



Linear rights of way and transportation infrastructure such as the High Line could be used to insert pneumatic collection into existing neighborhoods.

Paris Trilib'

Type

Shared surface container on curb

Best Practice Strategies

- 3.05 Shared surface containers in the public realm or on agency property
- 3.08 Design streetscapes that allow curbside access to containers

Summary

Paris is a low-rise city with one of the highest population densities in Europe. Most buildings are six stories or fewer. Residents are accustomed to bringing their waste and recyclables down to street-level receptacles inside their building. Each morning or night, building staff roll bins from courtyards and entryways to the curb for collection by semi-automated trucks.³³ Paris collects three streams curbside—refuse, recyclables and glass— and may add a fourth: organics (an organics collection pilot was started in two districts in 2017). Meanwhile, many buildings do not have room to store enough wheeled bins to manage the volume they generate. Citywide, 30% of buildings have no receptacles for glass, and 15% still provide only refuse bins.³⁴

While hosting the United Nations Climate Change Conference in 2016, Paris set out to expand access to recycling collection by introducing a new kind of street furniture.³⁵ In the spirit of the city's wildly popular bike sharing program, Vélib', the new recycling kiosks are called Trilib' (from *trier*, "to sort"). The kiosks have foot pedal-operated openings



Above:
Trilib' recycling station
in a parking space

Left:
Trilib' waste streams
are collected by several
different entities
including the nonprofit
Carton Plein who collects
salvaged boxes by cargo
bike and sells them for
reuse.

on the sidewalk side and a street-facing door from which sanitation crews remove a wheeled container. Trilib' kiosks include four to six modules providing access to up to five streams: metal and plastic packaging, paper and small cardboard, glass, textiles and large cardboard, each color-coded with its own type of opening. The number and type of containers varies depending on waste generation characteristics in the immediate area.

Trilib' is designed to address a number of issues beyond a lack of storage space within buildings and low recycling rates. These other objectives include giving recycling new legitimacy as an activity deserving of a prominent location in public space and normalizing drop-off down the street as a complementary practice in a city used to door-to-door pickup. The repurposing of parking spots for new kiosks also reinforces the city's commitment to shifting space away from cars.³⁶

In 2017, as part of a pilot program, 40 Trilib' stations were installed in four urban contexts: superblocks of apartment towers, town houses, major public spaces and the historic city center. Preliminary results are encouraging. The volume of material collected via Trilib' has increased from 50 tons the first month to almost 80 by the sixth. The city envisions installing 1,000 stations by 2020 and is contemplating adding additional containers for other types of material.³⁷

Challenges³⁸

- Capacity: The project team is looking at ways to redesign the kiosks to increase capacity and reduce collection frequency, particularly for bulky materials like cardboard.
- Bulky cardboard: Initially, a large opening was provided for bulky cardboard, but this led to problems with overflowing and contamination. Kiosks were modified with a slot opening similar to a large mailbox's, which seems to be working.
- Noise: The first glass containers were too noisy. The problem was solved by adding sound insulation.

Applicability to NYC

Specially designed surface containers could be installed in public plazas or parking spaces to expand access to recycling in NYC neighborhoods where there is not adequate space for waste storage. Reconceiving bins as public amenities akin to bike-sharing equipment, as Paris has done, could be helpful in siting drop-off stations for a range of materials.

The Hague, Netherlands

Type:

Submerged container

Best Practice Strategies

- 3.06 Shared submerged containers in the public realm or on public agency property
- 3.09 Incorporate community into collection operations

Summary:

The Hague is the Netherlands' third-largest city. Until recently, door-to-door collection of refuse in bags or wheeled bins was the norm, with residents carrying recyclables to shared containers on certain "recycle streets." The city struggled to keep its narrow streets clean because seagulls pecked open bags left out for collection, strewing garbage and making a mess. In 2009, The Hague decided to address the issue by replacing bags on the curb with shared containers submerged under the sidewalk.³⁹ Although the city anticipated some operational efficiencies, its primary objectives in selecting a submerged container system were to improve public and health and hygiene, enhance public space aesthetics and provide an opportunity for residents dispose of refuse 24/7 instead of having to store the material in their small apartments until pickup day.⁴⁰ (Recycling is already collected at drop-off locations.)

The Hague began switching to submerged containers in 2010 with a plan to install more than 10,000 units in three phases over ten years. In 2017, there were 6,100 belowground units. Eventually, all collection in The Hague



Clockwise from top: Submerged containers installed in a curb extension; truck removing container

will shift to underground containers. The containers are designed to be within convenient walking distance (250 ft, or 75 meters) of a residential building's front door. (If necessary, the containers may be installed at distances up to 410 ft, or 125 meters.) Each 6.5 cu yd container serves an average of 35–38 households. They are emptied twice weekly and are cleaned, inside and out, twice a year. Equipment is checked once a year.⁴¹

The installation process is described in detail on the city's website. Container location plans are made in collaboration with the municipal committee for public space (an entity composed of key street infrastructure stakeholders, which coordinates short-, medium- and long-term planning), the departments of transportation and environmental services. The city digs test pits in chosen locations to survey underground conditions and informs local residents of the plans. Area residents have the right to object, and if their objections are not resolved to their satisfaction, they can appeal in court. (This has happened in 10% of the cases.) Community outreach occurs at several levels: Information is available online and letters are sent to all residents to explain why the change is being made. During the neighborhood information evenings that are organized to discuss plans with the community, residents can volunteer to be responsible for a submerged container and receive the tools to repair basic jams. Volunteers are usually the first to call when issues arise.

The primary operational change for collection personnel is that truck crews are reduced from three to one, and some training is needed to provide the skills needed to manage the equipment.⁴² The shift

to submerged containers has led to improved working conditions and reduced labor costs. A shift from fixed routes to a flexible “smart schedule” based on sensors will be implemented next.

Challenges

Although litter is reduced, the city maintains a cleaning crew to address the 2–3% of locations where bags are improperly discarded beside containers. There is a fine for illegal dumping, but identifying an owner is nearly impossible. Community involvement and ownership is the most powerful solution.⁴³

Applicability to NYC

New York City is similar to The Hague in that it is a dense city with infrastructure and utility systems running under its streets. The Hague's implementation process, involving coordination among key street infrastructure agencies, with test pits to check field conditions, would be appropriate in NYC as well. DSNY's existing Adopt-a-Basket program could be expanded to include training volunteers to be first responders who could resolve minor maintenance issues with their “adopted” submerged containers. (See [BPS 3.06](#) for collection considerations.)

Punt Verd, Barcelona

Type

Neighborhood-scale recycling center in public realm

Best Practice Strategies

- 3.07 Staffed drop-off locations
- 3.09 Incorporate community into collection operations

Summary

Punts verds (Catalan for “green points”) are small recycling centers installed in plazas and parks. Barcelona developed the semi-permanent staffed facilities to provide residents with opportunities to drop off household hazardous waste, recyclables and smaller bulk items within walking distance of their homes. Punts verds complement larger recycling centers with vehicle access on the outskirts of the city. In 2016, the city’s 23 neighborhood-scale punts verds managed over 2,000 tons of material.⁴⁴

The facility design is simple: containers are arranged in such a way that they are accessible for deposits by the public on one side and for emptying by staff on the other. The center is protected from the elements and secured with fences. The only interior spaces are a small office with a restroom for staff and a tiny visitor’s center. Punt verds are designed to be eye-catching to encourage their use and to add visual interest to the surrounding public space. They also provide an opportunity to showcase sustainable design. The modular facility installed in Barceloneta Park in 2013,

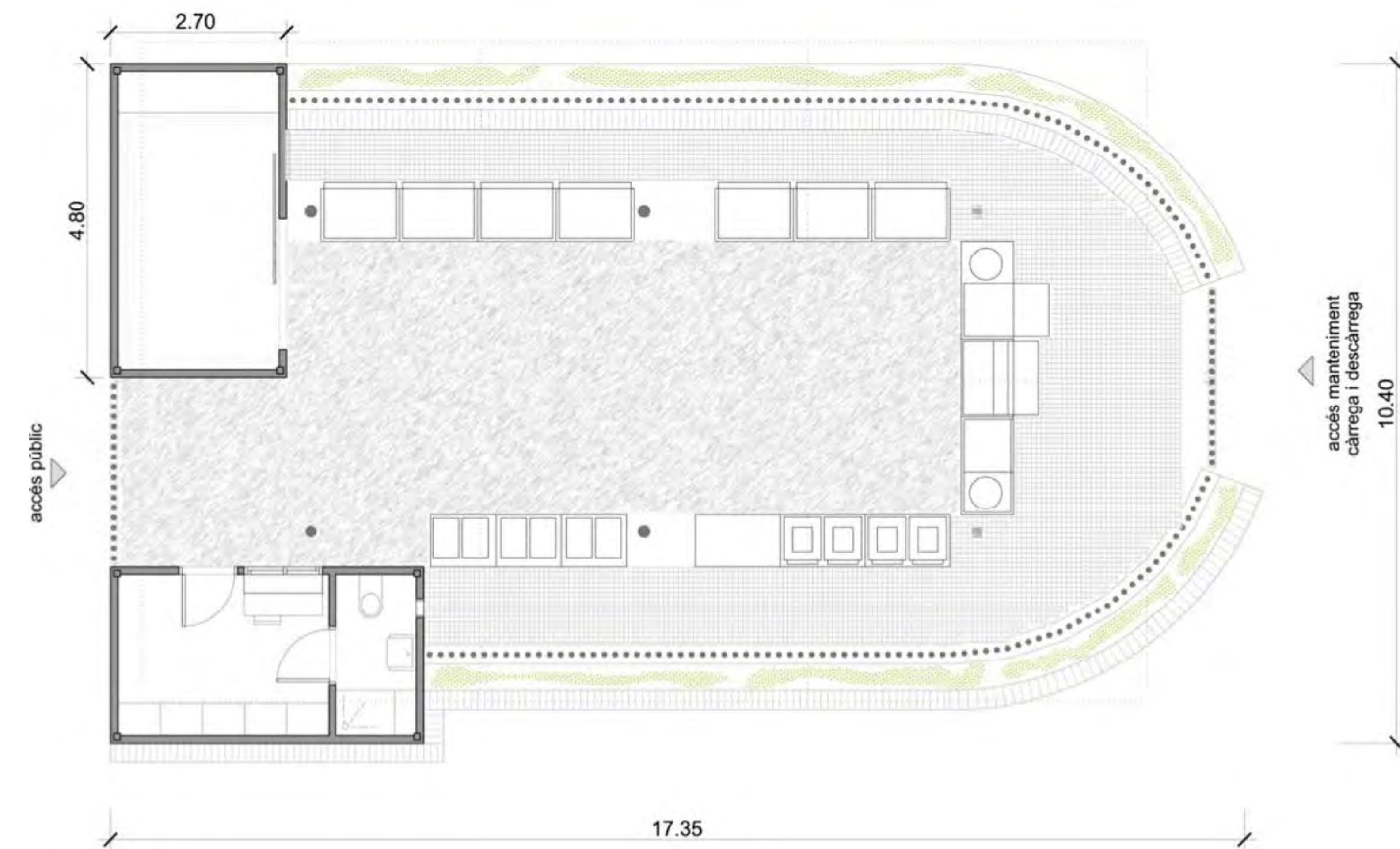

View of pedestrian entrance; Plan showing containers arranged around a public drop off area with service access around the perimeter

by Picharchitects, features a planted enclosure and requires little energy for operations: Roofs protecting the drop-off area capture rainwater and fill cisterns used to irrigate planters; solar panels and passive systems generate electricity and hot water.⁴⁵

Challenges

Architect Felipe Pich-Aguilera Baurier explains: This is not a conventional project. Every aspect had to be invented from scratch to break with the conventional image of a waste plant. A waste project is always subject to “industrial” constraints, such as accommodating truck logistics and ensuring that the site is protected from contamination. For this project, very restrictive safety and hygiene measures were also necessary to ensure coexistence within the urban fabric. As a result, projects tend to be isolated like “bunkers” and would be intimidating to pedestrians and neighbors. Our project tries to achieve a domestic-scale result that can be a meeting place for the neighborhood, while addressing all of the program requirements.

Given that the installation is located at the edge of an urban park, we have tried to design the largest elements so that they assimilate directly with the natural landscape that surrounds them and ensure that no permanent mark is left on the ground. To do this, all the components have been manufactured offsite and assembled so that the facility can be dismantled and removed.⁴⁶

Applicability to NYC

New York City runs SAFE disposal events throughout the five boroughs, where the events are typically well attended and waiting lines can last for hours. Research elsewhere has shown a spike in trash disposal of hazardous waste on days following collection events. Permanent facilities providing predictable, ongoing access to collection could capture a larger portion of materials designated for diversion from regular disposal.



Interior view showing receptacles for various materials

Ménilmontant, Paris

Type

Recycling center and relay point for bulk collection hosted on private property

Best Practice Strategies

- 3.07 Staffed drop-off locations
- 3.09 Incorporate community into collection operations

Summary

The City of Paris and Paris-Habitat OPH, a public housing management company, are building a new mixed-use residential complex of 87 units in the Ménilmontant neighborhood of the 20th arrondissement. In addition to the more conventional park and sports complex, the project, designed by Atelier Nadau Lavergne,⁴⁷ includes a staffed recycling center or “espace tri”, as well as a hub for aggregating truckloads of bulk materials picked up by appointment from local collection routes. Parisians are already required to bring household hazardous wastes and other material not collected curbside to an espace tri, where materials are staged and sorted before being sent to processing or disposal facilities. These centers tend to be open-air facilities in industrial areas around the expressway that circles the city, with difficult pedestrian access.

The 15,000-square-foot espace tri was included in the program for a mixed-use building in an effort to bring recycling centers closer to where people live and design them in ways that minimize impacts from their operation.⁴⁸ The hub for aggregating loads of bulk materials,

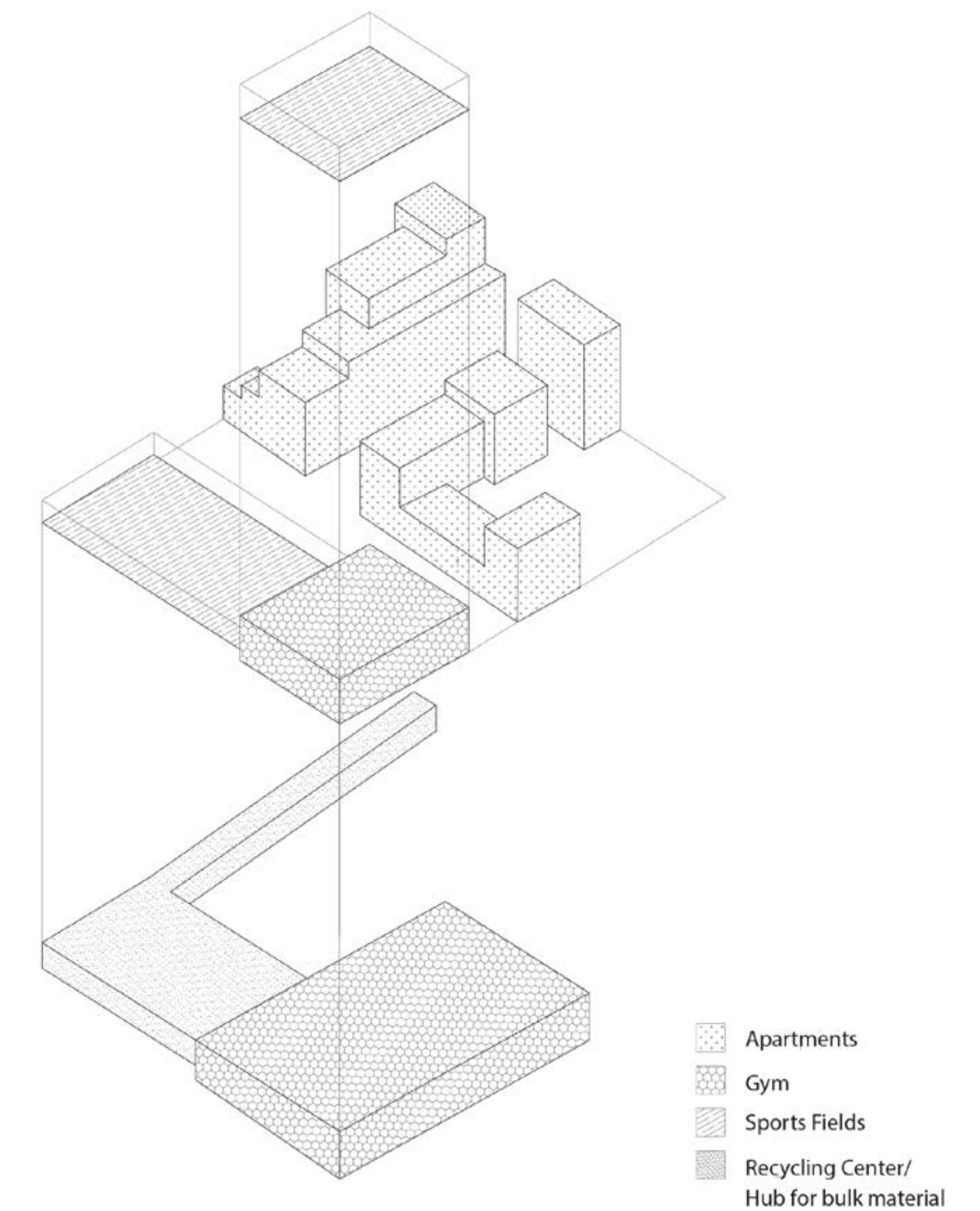

Clockwise from top: Section perspective showing vehicles driving into the recycling center adjacent to the gym; Diagram showing the various program elements; View showing pedestrian-oriented context

called the Point Relais d'Encombrant, will reduce miles logged by collection trucks, in turn decreasing congestion and air emissions. By 2020, every arrondissement will have a center—coordinated by a partner organization—where residents will be able to take items for reuse as well as recycling and disposal. To reach this goal, the City will build ten new espaces tri, including the one in Mènilmontant, the first to be located in a residential complex.⁴⁹

Challenges

The project team must reassure neighbors that any negative impacts from this new type of facility will be mitigated.

Applicability to NYC

New York City does not have a network of neighborhood-scale facilities collecting household hazardous waste and other non-daily streams. Both the Mènilmontant and Barcelona programs offer convenient and reliable access to neighborhood drop-off facilities. City agencies could specify that publicly funded projects host such facilities, along with the logistics support required to operate and maintain them. (See the [Barcelona Punt Verd case study](#).)

Right: Plan of basement level; municipal vehicles stage material in large containers while the public drops off at small containers the length of the exterior wall

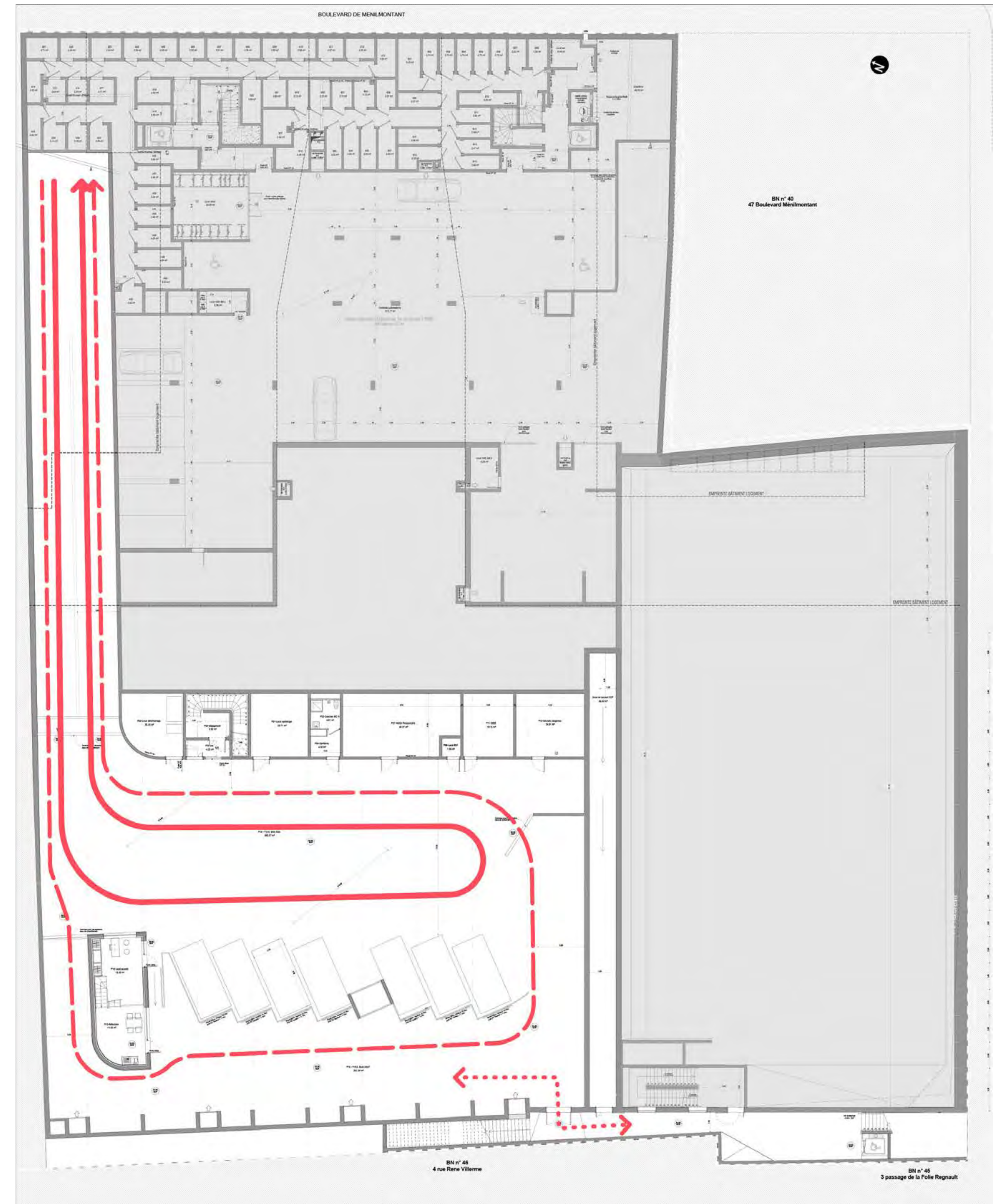

GrowNYC Compost

On-The-Go Program, NYC

Type

Staffed drop-off locations in the public realm

Best Practice Strategies

- 3.07 Staffed drop-off locations

Summary

Dedicated New York City gardeners have composted in their community gardens for decades as a way to improve soil for flowers and vegetables. In 1993, the New York City Department of Sanitation created the NYC Compost Project to leverage this interest in composting and began formally training community gardeners through the city's botanical gardens to become certified master composters. DSNY has since expanded the scope of the compost project to help develop organics collection and processing capacity in the city with the Local Organics Recovery Program (LORP). LORP sites collect food scraps from the larger community and process them in their urban compost sites.

Concurrently, DSNY began funding collection programs in farmer's markets, parks, libraries and commuter drop-offs at subway stations.⁵⁰ These drop-offs are intended to complement curbside collection, providing convenient access to organics collection for all New Yorkers by 2018.⁵¹



Commuter drop off at transit hub

The newest DSNY-funded food scrap drop-off effort is called Compost On-The-Go, operated by GrowNYC, DSNY's nonprofit partner. GrowNYC compost coordinators set up a tent with bins or crates for organics and a refuse bin for any plastic bags used to transport material. For commuter drop-offs, bins are placed on street corners near a subway entrance in time for the morning rush hour. In addition to managing the bins, coordinators provide education and outreach about the importance of organics diversion in NYC. Commuters tend to travel at the same time each day, so volumes increase from week to week as people learn about the program and start saving their food scraps for drop off on their way to work.

Citywide, there are now 106 food scrap drop-off sites.⁵²

Challenges

Unlike the curbside program, in which organics are treated in industrial facilities, the drop-off program often uses urban compost facilities and gardens that are only allowed to accept plant-based material.⁵³



Left:
Food scraps dropped into DSNY toter

Above:
Crates of food scraps
at a GreenMarket drop-off

References

1. Public space litter bins are described, but there is no discussion of waste flows from buildings. New York City Department of Transportation, "Street Design Manual" (12/2015): 183. <http://www.nyc.gov/html/dot/html/pedestrians/streetdesignmanual.shtml>.
2. [Prior to instituting separate collection of organics] the DSNY collection fleet traveled about 25 million miles a year, while the private collection fleet traveled about 23 million miles. DSNY, "2012 Annual Report on Alternative Fuel Vehicle Programs Pursuant to Local Law 38 of 2005," 1. http://www.nyc.gov/html/dcas/downloads/pdf/fleet/fleet_local_law_38_DSNY_2012_final_report_3_25_2013.pdf; DSNY/BIC, "Private Carting Study, Executive Summary" (8/17/2016): 6. http://www1.nyc.gov/assets/dsny/downloads/pdf/studies-and-reports/Private_Carting_Study_Executive_Summary.pdf.
3. New West Technologies LLC, "Multi-Fleet Demonstration of Hydraulic Regenerative Braking Technology in Refuse Truck Applications," final report prepared for NYSERDA and NASEO (12/2011): 19.
4. New Yorkers file more official complaints about garbage trucks than any other source of noise. In 2012, 5% of all 311 calls concerned garbage trucks. John Metcalfe, "Yo, I'm Trying to Sleep Here! New York's Wonderful Map of Noise," *Citylab* (4/15/2013). <https://www.citylab.com/life/2013/04/yo-im-trying-sleep-here-new-yorks-wonderful-map-noise/5279/>.
5. The fatality rate for waste collection workers is 38.8/100,000; police, 13.5; firefighters, 2.5. U.S. Bureau of Labor Statistics, National Census of Fatal Occupational Injuries, 2015 (12/16/2016), <https://www.bls.gov/news.release/pdf/cfoi.pdf>; Fact Sheet, Police Officers (8/2016), <https://www.bls.gov/iif/oshwc/cfoi/police-officers-2014.htm>; Firefighter Factsheet (7/2013), <https://www.bls.gov/iif/oshwc/cfoi/osar0017.htm>.
6. Charles Komanoff and members of Right of Way, "Killed by Automobile," 3/1999 (cited by James Rutenberg, *NY Daily News*, 4/5/1999). Nationally, the most overall traffic fatalities caused by trucks are caused by dump trucks (5.96 fatalities per 100 million miles), while garbage trucks are second overall (5.12/100m). Jonathan Rosenfeld, "Commercial Truck Fatality Statistics," 5/1/2013. <https://www.rosenfeldinjurylawyers.com/news/commercial-truck-fatality-statistics/>.
7. Cleaning staff, together with police officers, nursing aides and tractor-trailer drivers, account for most workers' compensation claims (20% of all claims), and strains and sprains from material handling and lifting are the leading cause of injury for all workers (30% of all cases). "Workers' Compensation: Five Most Common Injuries," *National Law Review* (11/3/2016). <https://www.natlawreview.com/article/workers-compensation-five-most-common-injuries>.
8. See DSNY/BIC, "Private Carting Study" (8/17/2016). <http://www1.nyc.gov/assets/dsny/about/inside-dsny/private-carting.shtml>.
9. Manual collection crews lift on average of 6 tons per worker per shift, leading to increases in musculoskeletal injuries. Pamela McCauley Bush et al., "Ergonomic & Environmental Study of Solid Waste Collection" final report, Environmental Research and Education Foundation (2012): 3. <https://erefdn.org/wp-content/uploads/2015/05/EREF-Ergonomics-in-Waste-Collection-Final-Report-PDF.pdf>.
10. "The Centers for Disease Control and Prevention considers plastic bags inappropriate for outside overnight garbage storage because rats and other animals can and will chew through the bags [CDC, 2006]. The consistent availability of curbside food waste trains rats to return to these locations and makes eradication difficult, as indicated in our findings of greater rat activity near restaurants." Sarah Johnson et al., NYC DOHMH, "Characteristics of the Built Environment and the Presence of the Norway Rat in New York City: Results From a Neighborhood Rat Surveillance Program, 2008-2010," in *Journal of Environmental Health* (June 2016): 27. Recognizing the role of bagged waste in rat infestations, the city is proposing to reduce time bags can sit on the curb. "The [rat mitigation] plan proposes a local law that requires buildings containing more than ten units within the Mitigation Zones to curb garbage after 4am the day of trash collection, greatly reducing the availability of rats' food source." The City of New York, "De Blasio Administration Announces \$32 Million Neighborhood Rat Reduction Plan," (6/12/2017), <http://www1.nyc.gov/office-of-the-mayor/news/472-17/de-blasio-administration-32-million-neighborhood-rat-reduction-plan#/0>.
11. See Bush et al., "Ergonomic & Environmental Study," 4.

12. NYC DHHMH researchers suggested “hard-sided containers could help reduce or prevent rat infestation” and initiated a pilot including containerization to target rat reservoirs. See Johnson et al., “Characteristics of the Built Environment,” 28.
13. “Almost half [of overexertion injuries and lost work days] involved lifting, throwing, or carrying garbage containers, whereas 4% of overexertion injuries were caused by pushing or pulling waste containers.” Bush et al., “Ergonomic & Environmental Study,” 4.
14. Use of wheeled bins with automated collection may require changes in union or labor agreements, truck retrofits, or require operational changes by building management.
15. Bags need to be manually lifted each time they are moved from point of origin to temporary storage location to setout at the curb. By containing multiple bags, bins reduce the number of lifts required.
16. The need for a round trip with an empty container could be avoided—and truck miles effectively halved—if a system similar to those used for railcars or port-truck chassis were developed, in which the containers are centrally owned and provided by the system operator as part of collection service. See Benjamin Miller, “Managing New York’s Municipal Solid Waste to Support the City’s Goal of Reducing Greenhouse Gases by 80% by 2050,” white paper for the New York League of Conservation Voters (7/13/17): 14.
17. Refer to the waste calculator to determine whether a building will generate enough waste to make a container the optimal option.
18. Rae Zimmerman et al., “Expanding the Use of Roll-On, Roll-Off Trash Compactor Technology to Reduce Rodent Infestations in New York City: NYC Private Multiple-Dwelling Deployment Assessment,” NYU Wagner School of Public Service Institute for Civil Infrastructure Systems (6/2009): 4. https://www1.nyc.gov/assets/doh/downloads/pdf/rats/trash_compactor.pdf.
19. “[NYC] DOT will explore opportunities for micro freight distribution centers in highly congested commercial areas. These centers might be sited in curb space now dedicated to commercial loading, encouraging off-hour delivery and more efficient collection of recycled materials and waste.” NYC DOT, *Strategic Plan 2016*, 105. <http://www.nycdotplan.nyc/freight-movement>.
20. Benjamin Miller et al., “Costs and benefits of pneumatic collection in three specific New York City cases,” in *Waste Management* 34, no. 11 (2014): 1958.
21. Some maintenance issues on Roosevelt Island result from the fact that steel pipe is direct buried and is inaccessible where it passes under buildings. David Stone, “Challenged Daily by a Mixed Bag of Problems, Engineer Tom Turcic Tends Roosevelt Island’s Aging Infrastructure,” in *Main Street Wire* (11/7/2009): 10.
22. New York relies on the use of the DSNY fleet for snow removal. Citizens’ Budget Commission, “12 Things New Yorkers Should Know About Their Garbage” (5/2014): 14. http://www.cbcny.org/sites/default/files/REPORT_GarbageFacts_05222014.pdf.
23. “Bags were still being used in 4% of the surveyed communities.” “The 2016 State of Curbside Report,” The Recycling Partnership, (1/31/2017): 12. <https://therecyclingpartnership.box.com/s/i0wvano7hi3dr3ivqyv689y4zzo583l2>.
24. Battery Park City Parks Conservancy, “Who We Are,” <http://bpcparks.org/about-us/who-we-are/history/>.
25. Rigorous environmental standards were added in 2000 and updated in 2005. Battery Park City Authority, “Residential Environmental Guidelines” (5/2005), http://bpc.ny.gov/wp-content/uploads/2015/03/BPCA_Residential_Environmental_Guidelines.pdf.
26. Cheryl McMullen, “How a Compacting Program for NY’s Battery Park City Has Improved Quality of Life,” in *Waste 360* (5/18/2017), <http://www.waste360.com/residential/how-compacting-program-nys-battery-park-city-has-improved-residents-quality-life>.
27. Bill Egbert, “Sanitation Salvation? Battery Park City May Hold the Key to Conquering Downtown’s Garbage Glut,” in *Downtown Express* (6/16/2016), <http://www.downtownexpress.com/2016/06/16/sanitation-salvation-battery-park-city-may-hold-the-key-to-conquering-downtowns-garbage-glut/>.
28. See *Fast Trash: Roosevelt Island’s Pneumatic Tube and the Future of Cities* (2010), <http://fasttrash.org>.
29. Anne Allain and Bruno Allieux, *Pneumatic Waste Collection in Vitry-sur-Seine* (presentation, International Pneumatic Waste Collection Association seminar, Barcelona Smart City Expo World Congress, 11/16/2016), https://docs.wixstatic.com/ugd/c79e2d_d8505c9aa8f24ed3a2a88feb9d9cb88e.pdf.
30. City of Vitry-sur-Seine, “Collecte pneumatique: le réseau s’étend” (9/30/2016), <https://www.vitry94.fr/actualites/fiche/collecte-pneumatique-le-reseau-setend/?cHash=06005dbf4352e23ea5bd26bf43c40eed>.

31. Fanny Delporte, “Vitry: Ils sont descendus dans le ventre de la collecte pneumatique des déchets,” in *Le Parisien* (5/20/2016), <http://www.leparisien.fr/vitry-sur-seine-94400/vitry-ils-sont-descendus-dans-le-ventre-de-la-collecte-pneumatique-des-dechets-20-05-2016-5814263.php>.
32. Cole Rosengren, “Below the High Line: How pneumatic tubes could alter the future of urban waste collection,” in *Waste Dive* (4/6/2017), <http://www.wastedive.com/news/below-the-high-line-how-pneumatic-tubes-could-alter-the-future-of-urban-wa/439845/>.
33. City of Paris, Annual Report on Sanitation Service, 2015,” 39, <https://api-site-cdn.paris.fr/images/86839>.
34. City of Paris, Annual Report, 60.
35. “Paris Teste le Tri de Demain : Trilib,” *Eco-Emballages* blog (undated), <http://www.ecoemballages.fr/trilib>.
36. Correspondence with Léon Garaix, deputy director, Paris Office of the Deputy Mayor for Sanitation (7/19/2017).
37. See note 33
38. See note 33
39. The city found reduced litter where submerged containers were used. “Plans for More Underground Waste Containers,” in *The Hague Online* (7/25/2012), <http://www.thehagueonline.com/news/2012/07/25/plans-for-more-underground-waste-containers-2>.
40. Arjen Baars (director, The Hague Environmental Services) and Richard van Coevoorden (project manager, Department of City Management of the City of The Hague), correspondence with Juliette Spertus, 6/22/2017. Coordinated and translated by Tessa Vlaanderen.
41. The Hague is technology-neutral and has ten-year contracts with multiple vendors. Arjen Baars, 6/22/2017.
42. One sanitation worker would be possible, but the perceived security risk and difficulty of maneuvering narrow streets made them keep two. Arjen Baars, 6/22/2017.
43. Arjen Baars, 6/22/2017.
44. See Neighborhood Puntos Verdes labeled “B” in location map, City of Barcelona, Xarxa Puntos Verds, <http://ajuntament.barcelona.cat/ecologiaurbana/sites/default/files/XarxaPuntsVerds.pdf>.
45. Picharchitects, “In Process: Punt Verd, Nuevo Modelo de Punto Verde en la Barceloneta,” Picharchitects (blog, undated), <http://www.picharchitects.com/en/in-process-punt-verd-nuevo-modelo-de-punto-verde-en-la-barceloneta-ii/>.
46. Note from architect, Felipe Pich-Aguilera Baurier, 9/2017. Translated and edited by Juliette Spertus.
47. Nadau Lavergne website, <http://www.nadaulavergne.com/#menilmontant>.
48. “Une déchèterie sous le sol de Paris,” in *Environment Magazine* (9/23/2015), <http://www.environnement-magazine.fr/article/44602-decheterie-sous-sol-de-paris/>.
49. Laetitia Van Eeckhout, “Très mauvais élève, Paris se lance vers le ‘zéro déchet’” in *Le Monde* (2/16/2016), http://www.lemonde.fr/planete/article/2016/02/16/tres-mauvaise-eleve-paris-se-lance-vers-le-zero-dechet_4866125_3244.html#yupLUTOWCS9owSpx.99.
50. Nora Goldstein, Part I: “Community Composting in New York City” (1/2013), <https://www.biocycle.net/2013/11/18/community-composting-in-new-york-city/>, and Part II: “Greenmarkets Facilitate Food Scraps Diversion in NYC” (2/2014), in *BioCycle*, <https://www.biocycle.net/2014/02/21/greenmarkets-facilitate-food-scraps-diversion-in-nyc/>.
51. NYC DSNY, “NYC Organics Collection: Neighborhoods Served,” <http://www1.nyc.gov/assets/dsny/zerowaste/residents/nyc-organics-collection.shtml>.
52. Correspondence with DSNY, September 2017.
53. GrowNYC, “Compost Food Scraps,” <https://www.grownyc.org/compost>.

Policy, Research & Implementation Recommendations

225	Policy Suggestions
232	Research Recommendations
234	Implementation Recommendations
239	References

The core of the guidelines is a set of strategies to design our built environment to serve OneNYC’s visionary goal of zero waste. They were developed over a year of intensive fact-finding, six collaborative workshops, and the involvement of many city agencies and private stakeholders (see [About the Guidelines](#)). During this period, we ¹ witnessed the energy and motivation of our ever expanding “advisory committee” and its excitement in finding others to work with toward this goal. As Bridget Anderson, DSNY Deputy Commissioner for Recycling & Sustainability, said in the final workshop:

“This whole process has been one of exhaling. Now there are more people involved, not just Sanitation, and we need everybody. There’s been so much creativity and vision on display, and I’m excited for it to continue.”

The statements highlighted below were made by participants in the final workshop, in response to the question “What value do the guidelines have for you?”

“The guidelines create a bridge between the urban planner and the architect, with waste being a part of their jobs and their role in the city.”

—Matt de la Houssaye of Global Green USA

The implementation phase will demand even more creative collaboration across disciplines, agencies and stakeholders. We need the active engagement of the design community, with their strengths as 3-D



Bridget Anderson, DSNY discussing implementation at final workshop

problem solvers, to make our sidewalks and streetscapes do even more. The management of waste has not traditionally been part of street or building design, so making that change will require that we inspire the design community to come up with solutions that spur New Yorkers into embracing a zero waste lifestyle.

“I was intrigued by implementing these ideas in an architecturally and urbanistically beautiful way to engage and influence behavior.”

—Gregory Kiss of Kiss + Cathcart, Architects

The process can tap creativity while educating the next generation of designers.

“I can see using the guidelines in the classroom to come up with new design ideas.”

—Kaja Kühl of Columbia University

As strategies are applied to pilot designs in NYC, we’ll need to assess their success and refine designs in an iterative process. DOT has followed this process with its temporary plazas that, if successful, become permanent.² What works in one urban condition may not work in another, but following these strategies will lead to many design solutions.

“We discussed bridging the gap between high-level systems thinking as well as practical implementation.”

—Tessa Vlaanderen of Circular Futures

We will need waivers from codes and policies for some of these pilots, which lead to permanent changes in policies and codes to allow and incentivize implementation of the strategies on a larger scale.

The guidelines should be a living document, updated regularly with new data from research and evaluation of pilots and reflecting changes in policy implemented.

“I appreciated the feedback from research on every aspect.”

—Laura Rosenshine of Common Ground Compost

Policy Suggestions

The following suggestions are preliminary—further research and evaluation are needed to determine specific policies.

Building Code Provisions for Storage, Management and Setout of Waste

Proposal RC 2 of NYC’s Green Codes Task Force, released in 2010 and made law by LL 60 of 2012, was to “Provide Recycling Areas in Apartment Buildings.”

The stated summary is:

In many buildings, the lack of dedicated space for sorting and segregating recyclables impedes recycling efforts. By increasing the allotted space for recycling bins and thus increasing awareness and accessibility for recycling measures, this law will increase the recycling rates for multifamily residential buildings.

The proposal added additional storage space for refuse and recyclables and required equal convenience disposal for recycling and trash in larger residential buildings with chutes by requiring 5 sq ft of floor area for recyclables in a refuse chute access room (unless there is a chute sorter or multiple chutes accommodating recycling).

Now that the city is starting to collect organics, there should be equal convenience disposal for organic waste as well, or diversion of those

materials will suffer due to reduced convenience of disposal. In other cities, such as San Francisco and Milan, equal convenience disposal has been achieved by discouraging or banning chutes.

There are two possible paths forward to create equal convenience disposal for trash, recycling and organics:

- Amend BC 1213 to require storage for organic bins in chute access rooms with sufficient ventilation. For this approach, porters would need to service the bins often enough to avoid odor concerns, or
- Consider removing the requirement for chutes so that all waste streams can be disposed of at a central or ground-floor location. This would allow for reduced staffing as well as easier oversight of the waste disposal, which may lead to higher diversion rates.³

See below for a discussion of research recommendations.

Storage Area Requirements for Residential Buildings

LL 60 /2012 also requires 1.5 sq ft per dwelling unit of storage for trash and recycling (or 1 sq ft/DU with compactor), min. 350 sq ft. Using calculations from average DSNY waste data, we do not think this is sufficient, especially with the rise in discarded cardboard.

Our Proposal

Evaluate a range of buildings and average the data to determine the optimal amount of storage space.



Options for equal convenience disposal: Central disposal on ground floor or waste rooms on every story

Storage Area Requirements for Waste in Commercial Buildings

There are currently no requirements for waste storage in commercial buildings, resulting in all waste being set out on sidewalk for hours, or waste taking over loading docks and pushing loading to the street.

Our Proposal

Require that a certain amount of storage space is provided per square foot of commercial space, possibly varying by occupancy.

Waste Management Plans for All Buildings

There are currently no requirements for storage and planning for waste management in buildings, or for equipment for reducing volume. Some municipalities require a waste management plan be submitted before buildings are approved. Typical plans include materials characterization; allocated square footage for storage of daily waste streams and bulk materials; plan for collection, separation and movement of materials from initial disposal to set out; and reduction programs and equipment.⁴

Our Proposal

Make a building waste management plan part of DOB's building approval process.

Builders' Pavement Plans to Indicate Setout Space for Waste Collection

Builders pavement plans (BPP) are required for all work resulting in a new or amended Certificate of Occupancy. Such work requires improving or refurbishing the sidewalk and portions of the street facing the building. These public rights-of-way are primarily under



Storage in loading dock pushes loading onto the street

the jurisdiction of DOT, so the BPP needs to adhere to those standards. The BPP needs to show sidewalk details such as curb cuts and grading, all sidewalk obstructions, street penetrations and encroachments, but there is no requirement for showing temporary storage of waste, which is allowed to stay on the sidewalk from 4 p.m. to 9 a.m.

Our Proposal

BPP to show setout space for waste based on calculations of the volume of waste generated. See BPS 2.04.

Zoning Resolution Changes to Require and Incentivize Provision of Space and Equipment for Managing Waste

Currently the zoning resolution has a few sections governing refuse. In some cases, it gives floor area deductions for waste rooms; in others, it requires or disallows refuse storage, or requires screening for refuse storage.

Zoning changes are a powerful tool for shaping a city's development. Requirements for compaction, containerization and floor area storage for waste can be evaluated, to understand whether zoning inhibits these best practices, or could be used to incentivize them. Collection of waste data from buildings employing these best practices can be compared with other buildings' and used to develop policy changes. Existing precedents and case studies from other cities should also be examined.

Requiring Containers and Compaction for Large New Developments

Our Proposal

Require the use of compaction and 20–40 cu yd containers for waste streams in large new developments. This would reduce the impact on public space on the street and reduce the volume of waste (see [Chapter 3 Recommendations](#)).

Floor Area Deductions for Waste Storage

Current floor area deductions are only for dumpster storage that's adjacent to loading docks in the Manhattan Core, or for trash rooms in quality housing developments. Increases in floor area deductions

or floor area ratio are often used as incentives to encourage developers to include public amenities such as plazas or for inclusionary or affordable housing.

Our Proposal

Provide further floor area-based incentives for waste management.

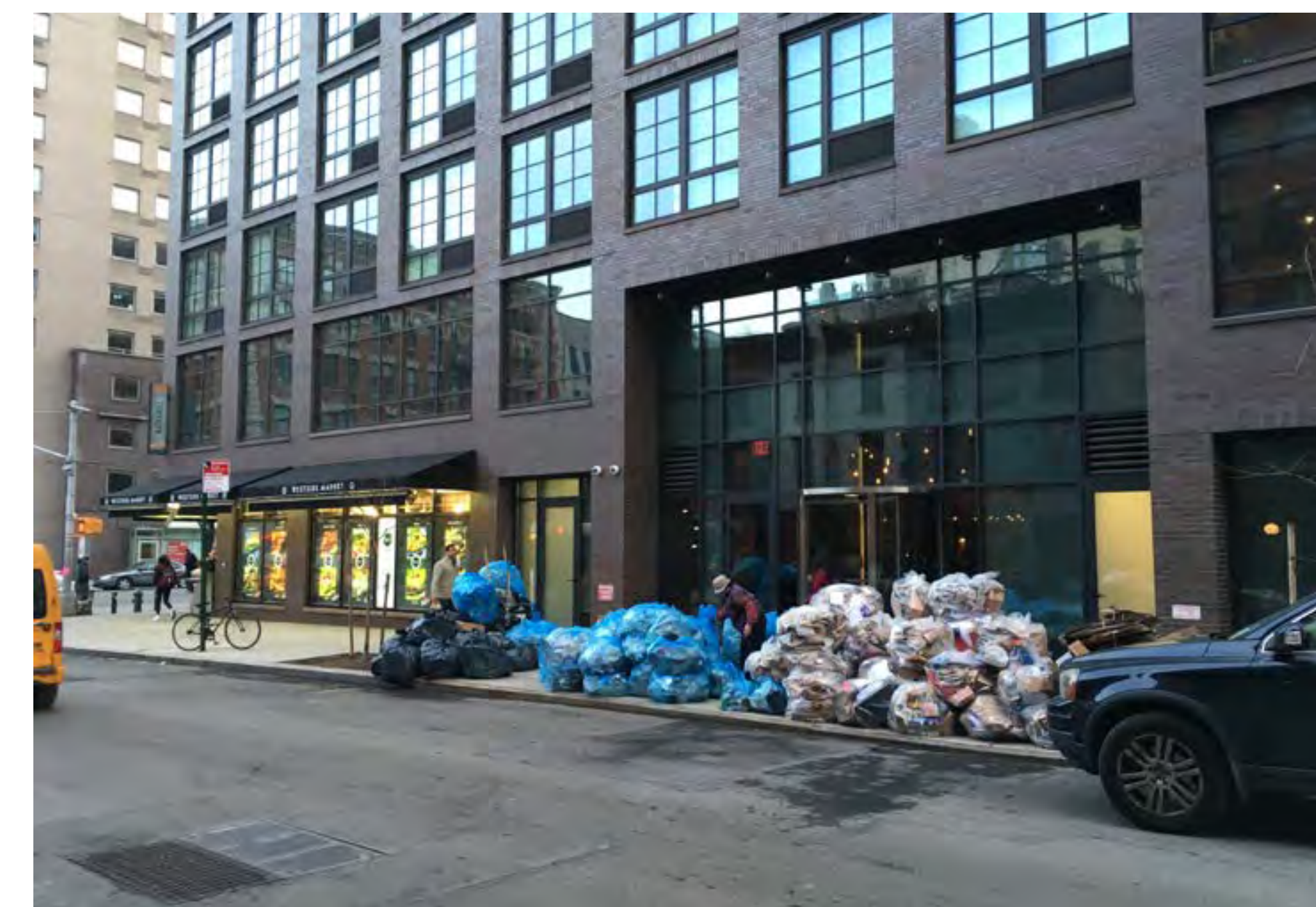

Unplanned setout

DSNY Rule Changes

Chapter 3 outlines the advantages of containerized and automatic collection. Currently DSNY only provides collection of 1–8 cu yd front-end loader (FEL) containers—also called EZ Paks—for grandfathered buildings.⁵ In the Collection workshop, a panel was held with representatives from DSNY, DOT and DCP to look at ways to further containerized collection.

Our Proposal

- Continue to work with DSNY to consider a policy change to allow collection of 1-8 cu yd containers in new developments.
- We understand that the following ideas are being considered by DSNY as part of the commercial zoning proposal, and we support them:
 - For commercial businesses, require transparent pricing per waste stream to incentivize waste reduction. This should be passed through to individual generators in multi-tenant buildings with shared waste facilities (similar to the submetering of electricity and other utilities).
 - Large waste generators should be required to conduct waste audits.

Multiagency Process to Move Toward Containerization and Automated Collection, Considering Streetscape Design and Logistics (MOS, DSNY, DOT, DCP)

The conversations started in the workshops, during which DCP, DOT, DSNY, Royal Carting representatives and advisory committee members explored possible changes to street design. These changes would require a move toward containerized and automated collection, as well as on-street siting of permanent waste collection infrastructure. The multiple challenges include to rodent-related issues, resident opposition to siting and maintenance.

“The dialogue between parties was valuable.”

—Sem Sepulveda of DSNY

“I found the interagency collaborations key.”

—Kate Mikuliak of DOT

We propose that a working group with representatives from city agencies and private stakeholders look at:

- Street and sidewalk rules to allow automated collection and use of public space where necessary for containers. This would consider using parking spaces, curb extensions and other means to create permanent and temporary storage for containers.
- Expansion of drop-off sites for low-volume fractions (textiles, e-waste, go-boxes), which could be achieved with temporary or permanent solutions that build on DSNY’s ongoing expansion of the organics drop-off program with more permanent infrastructure.
- Insights from the freight working group findings—to develop solutions that solve problems of increased deliveries and discarded packaging materials.
- Design of containers that work well and enhance streetscapes.
- Solutions with benefits for building owners, such as combining loading space or temporary parking with a shared container to head off opposition to placing waste collection facilities in front of a building.



Collection workshop; Street seats in parking lane

Multi-Stakeholder Process With MOS, UGC, AIANY, DSNY, DDC, Contractors and Developers to Devise Construction and Demolition Waste Reduction Policy

As part of the development of the guidelines, AIANY worked with Urban Green Council on developing Green Codes Task Force proposal RC2 on C&D waste. A group of stakeholders— among them, architects, interior designers, representatives from the carpet industry and major manufacturers, local reuse and carpet recyclers, contractors and city agencies—joined forces to understand the possible life cycles of carpet available today and the potential for moving to circular material flows. The process aimed to gather information to create a successful policy that would work toward a circular carpet economy.

Our Proposal

- Form a working group to develop policies for further discarded material streams, such as ceiling tile and gypsum wallboard, that would allow for more diversion.
- Offer innovation grants to help develop circular material loops, which could lead to materials such as concrete with recycled glass pozzolan as a cement replacement. (See [Building Product Ecosystems](#).)
- Develop a path to move the built environment into the circular economy by combining lessons learned from strategies developed elsewhere with an understanding of the NYC context.
- Consider requiring a deposit payment for demo permits for C&D waste, which would be returned if diversion targets were met (see [Chapter 2, Construction & Demolition Waste Context](#)).



Planned enclosures for waste bins at Navy Green by FXFOWLE Architects; waste bins stored on street on 9th street

Research Recommendations

Evidence-based policies require data. There is little data on actual building-level waste generation rates, the correlation between behavior and waste diversion and contamination or the various impacts of different collection strategies. Our overarching recommendation is to collect data that will allow evaluation of alternative procedures for reducing waste. The questions that follow related to behavior, operations and logistics and health illustrate the kinds of data that will be needed to develop and evaluate pilots and guide effective policy.

Behavior

Equal Convenience Location of Waste Streams

Research indicates that locating bins for recyclables and trash in the same place increases diversion rates.⁶ Municipalities such as San Francisco and Milan are basing their decisions to close trash chutes on the logical inference that making organics disposal as convenient as trash disposal will increase diversion. But trash chutes offer convenience, especially in high-rise buildings, and these cities have many fewer buildings with trash chutes than NYC does.

The relative costs and benefits must be better understood:

- How do co-location, convenience and visibility of bins for separate waste streams affect diversion and contamination rates and operations costs? (See [StuyTown case study](#).)

- How do physical factors such as building height and convenience of central waste area, and operational factors such as level of staffing, affect these outcomes?

Convenience of Disposal

Some research concludes that moving bins closer to an apartment improves diversion rates, but more data is needed.

Data and Feedback Loops

Could communicating waste data to generators and staff affect behavior?

- Does a display in the lobby showing waste generation and diversion rates lead to better performance?
- Do smart chutes and other methods to pass SAYT savings on to an individual make a difference? If they do, in what kind of buildings, and are they equally effective for all populations?⁷

Acceptance of Shared Containers and Drop Offs

In the U.S. today, waste containers are considered eyesores, best hidden from public view. What can we learn from cities that are experimenting with shared containers and bringing drop off facilities closer to where people live? (See [Punt Verd](#) and [Paris Trilib'](#) case studies.)

- Can the design of waste hubs create social activity and help nudge the public to perceive waste as a valuable resource?
- What is the maximum distance people will go to dispose of their waste?

- How does status of location affect use: i.e., within a courtyard or semi-private space, near public right of way but adjacent to an entrance, or on the curb?
- How does the planning and implementation process impact neighborhood acceptance?
- Could Adopt-a-basket type programs and other volunteer opportunities ensure that containers are kept clean and in good repair?
- How does container or facility design impact use?

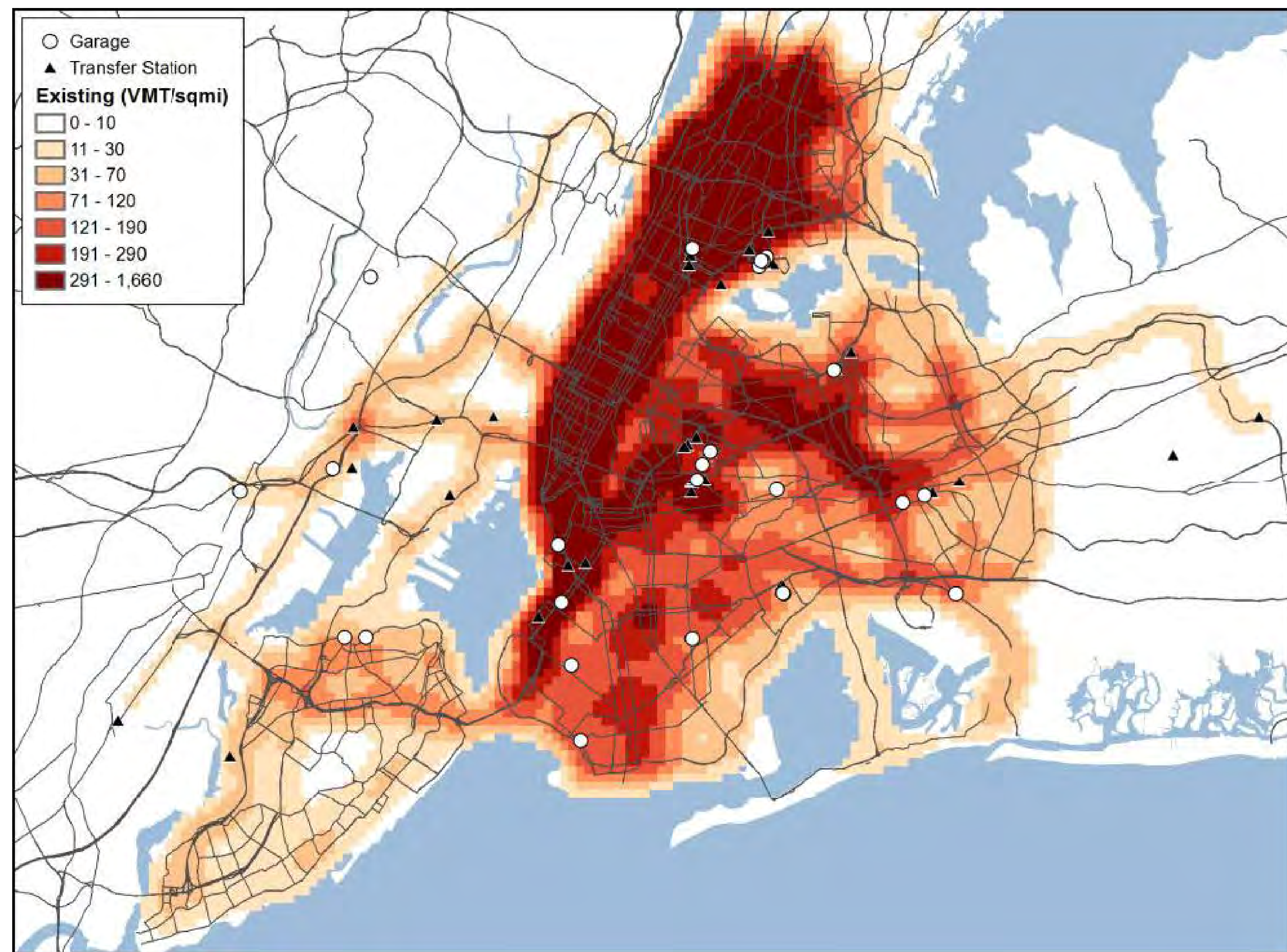

DSNY research looking at issues of vehicle miles traveled (VMT) and commercial collection

Operations and Logistics

Impacts of Containerization

Shared compactor containers were installed in Battery Park City to reduce rat populations, but they also ended up improving streetscapes, building operations, and collection efficiency. Data is needed on the costs and benefits of containerized collection.⁸ For example:

- How does containerization impact rodents and pests?
- How are building operations affected when waste is transported off site?
- How does waste handling (1-8 cu yd containers, wheeled bins or bags) impact worker injury rates?
- What are the relative impacts of trucks collecting containers versus manually loaded bags on air quality both in terms of hourly rates and aggregate emissions due to relative truck miles required?
- How do containerized and non-containerized collection impact accident rates, noise volumes and traffic congestion?
- Data is needed to determine the appropriate equipment for shared collection and drop off locations based on NYC-specific conditions.
- What capacity of shared container and what frequency of collection is appropriate for different neighborhoods and generator types?

Health

Waste Handling in Buildings and Asthma

It is well established that cockroaches, mice, and other garbage-loving pests cause asthma (both as risk factors for new cases and as attack triggers in asthmatic individuals).⁹ Little is known, however, about the potential asthma-related health ramifications of alternative waste handling strategies.

- What role do chutes, compacters, and waste storage strategies play?

When DOH Policies Increase Waste

There are many NYC DOH policies that lead to single-use items such as disposable containers and food handling gloves. It would be valuable to compare NYC policies with those in other places. For example, current policy does not allow businesses to place food in a container a customer brings from home.¹⁰ Current collaborations between DOH, industry and M-SWAB to develop best practices for reusable “to go” containers could be expanded with experiments aimed at protecting public health while decreasing waste.

- How significant is the risk of putting food into a container that a customer has washed in their own home compared to contamination that occurs within the store?
- Are there container filling practices that can minimize risk?

Implementation Recommendations

Increase the Use of the Guidelines by Designers

City Agencies to Include ZWDG in New Developments

City agencies have standards for development of new buildings. Incorporating ZWDG could include:

- Requiring that consultants use ZWDG in new developments
- Developing subpackages in collaboration with agencies, such as “ZWDG for affordable housing” or working with SCA to develop design guidelines for schools within their Green Schools Guide
- Working with Enterprise to include further credits for waste management in their Green Communities Criteria for affordable housing and with the New York City Housing and Preservation department to include in its overlay of these criteria

City Agencies to Look at Retrofitting Existing Public Buildings

NYCHA and DOE are working with DSNY to improve waste management in their existing buildings. Applying design strategies from the guidelines to public buildings could complement other strategies being considered. This could include:

- Working with the DOE to analyze the different types of schools and typologies of waste management, developing best practices for each in collaboration with teaching and custodial staff
- Teaming up with NYCHA and other agencies in a similar manner

Incentives for Developers to Include Waste Reduction Measures

Incentives for developers to include measures that help the city are common in other agencies. For example, DEP awards grants for innovative stormwater management practices. DSNY could give out similar grants for equipment that helps achieve zero waste goals.

- Incentive grants for technical pilots such as anaerobic digestion systems
- Incentive grants for neighborhood-scale consolidation strategies, such as pneumatics which improve quality of public spaces and reducing vehicle hours traveled

Education for Architects and Developers

- Hold Lunch and Learn presentations in the offices of individual architects, urban planners and developers (with AIA and GBCI continuing education credits given)
- Run training sessions run through AIA or Urban Green (analogous to energy code trainings)

Technical Assistance Grants

NYSERDA gives technical assistance grants to design teams for assistance in energy reduction methods. The money goes to an approved technical assistance provider. Similar grants, at a smaller scale could be given for waste management. Once a developer or owner has set up one successful system it would be easy for them to implement throughout their portfolio.

- Technical assistance grant to help design waste management system in a new building and troubleshoot for building staff during first year of operation

Design Competitions

Engaging and inspiring the design community through design competitions will create more design solutions and more visibility and dialogue around the issues. As was done in the Reinvent Payphones NYC design competition, the public can become engaged by voting for the best solution and commenting on designs. Such competitions could include:

- Creating a shared collection container for a public street
- Devising an intuitive and affordable recycling station that could become the standard for small NYC food businesses such as quick service restaurants, grocery stores and coffee shops

Increase the Use of the Guidelines by Building Management, Resident Groups and Private Businesses

Ambassador Program for Existing Buildings

- A citywide program for private residential buildings could allow property managers and residents to work together towards waste reduction and diversion goals. See [Toronto 3Rs case study](#).

Further Challenges Like the MOS Zero Waste Challenge for Commercial Businesses

- Competitions like the Mayor’s Towering Challenge in Toronto to “motivate building Property Managers, Superintendents, Owners, Boards, 3Rs Ambassadors and residents to improve waste diversion in apartments, condominiums and cooperatives.”

Building Management Technical Assistance, Training, Education and Incentives

- Work with cooperatives, management companies and unions on technical assistance, education and training programs, possibly with incentives.
- Set up a help line for building staff, like the one for LL84 benchmarking.
- Create a mentorship program for building superintendents to share knowledge and support colleagues in neighboring buildings.

Increase the Use of the Guidelines in Urban Spaces and by Community Groups

Community-Based Neighborhood Projects

Many strategies for collection include neighborhood-scale solutions.

- Work with local groups, from block associations to neighborhood associations and community boards can help get local input and apply best practices to the specific conditions.
- Hold neighborhood-based contests, such as the Brooklyn Botanic Garden’s Greenest Block in the borough, could be started for the block trying hardest to get to zero waste
- Extend the concept of DSNY’s Adopt-a-Basket program— for litter bin waste—to shared drop-offs, which a local business or BID could sponsor.



Microhauler collection of organic waste by BKRot



Consolidated collection points for waste streams; bags from street litter bin stacked at curb

Pilot Opportunities

- Community waste hubs with microhauler distribution could be created for drop-off of all streams, or less frequent streams like e-waste and textiles in parks or other public property (see [Punt Verd case study](#).)
- BIDs could expand their neighborhood improvement role by piloting consolidated collection points or hubs for waste and recycling. This would decrease truck traffic and reclaim sidewalk space currently given over to litter bins and bags of waste from private businesses and street vendors.
- EDC is interested in embodying concepts from the circular economy in their urban innovation labs. Working with EDC on a pilot building could incorporate the best practice strategies and data collection to create and showcase a zero waste building.
- Schools are looking for better ways to store and stage waste for collection. DSNY, DOE and DOT could collaborate to test submerged containers as a way to improve conditions.
- The multi-stakeholder process ClosedLoops has initiated, to consolidate waste at a district scale with pneumatic collection hubs under the High Line, could be developed in phases as a pilot. (See [High Line Corridor case study](#).)
- A new housing project with collection of all daily waste streams at the ground floor (see [Clichy-Batignolles case study](#)) would allow testing of a simple solution to co-locate collection of all streams, including organics. It would also provide a opportunity to research the relationship between convenience, contamination and co-location with an affordable low maintenance solution. (A code waiver would be required.)



Application to Other Cities

Developing Within a Resilient City Framework

- Working with a group such as 100RC or C40 would allow findings to be applied to other cities. The strategies from the *Zero Waste Design Guidelines* could be tied into a larger circular economy framework and include evaluation of the associated resilience benefits.



Community waste hub, see [Punt Verd case study](#); Impact Bioenergy micro anaerobic digester pilot, Seattle

References

1. The editorial “we” employed in this chapter refers to the members of consultant team developing the guidelines: K+C, ClosedLoops and Foodprint Group.
2. NYC DOT, “NYC Plaza Program Application Guidelines 2017,” <http://www.nyc.gov/html/dot/downloads/pdf/nyc-plaza-program-guidelines-2017.pdf>.
3. Empirical research on the effect of oversight, social pressures and convenience on recycling behavior in multifamily buildings is relatively new. See Calvin Lakhan’s “Out of Sight, Out of Mind: Issues and Obstacles to Recycling in Ontario’s Multiresidential Buildings,” in *Resources, Conservation and Recycling* 108 (2016): 3.
4. For an example of a waste management plan requirement, see the City of Vancouver, BC’s “Zero Waste Design and Operations Plan,” in *Rezoning Policy for Sustainable Large Developments* (2014): 14, <http://bylaws.vancouver.ca/bulletin/R019.pdf>.
5. While front-end load trucks are prohibited from attaching snowplows, snowplows can be added to rear-end load trucks equipped for semiautomatic collection of containers and wheeled bins.
6. Researchers found that logistical challenges in multi-unit and high-rise buildings reduce diversion of recyclables and organics by an average of 11% (especially if there’s a chute for refuse but not other streams). Judith A. Layzer et al., “Municipal Curbside Compostables Collection: What Works and Why,” work product of the Urban Sustainability Assessment Project, Massachusetts Institute of Technology Department of Urban Studies and Planning (2014), 25, <https://dusp.mit.edu/sites/dusp.mit.edu/files/attachments/project/Municipal%20Curbside%20Compostables%20Collection%20%20What%20Works%20and%20Why.pdf>; DSNY came to similar conclusions in its 2001 report “New York City Recycling in Context” (8/2001): 31, http://www1.nyc.gov/assets/dsny/docs/about_2001-recycling-in-context_0815.pdf.
7. Opportunities for chute interface are discussed in Jesse Shelpins and Matt Brewer’s “Smart Trash Chute,” *Sidewalk Talk* blog, Sidewalk Labs (8/2017), <https://www.sidewalklabs.com/blog/we-held-a-one-week-design-sprint-to-build-a-smart-trash-chute-heres-what-we-learned>.
8. NYC Department of Health and Mental Hygiene researchers are analyzing the impact of waste management strategies on rat infestations. Sarah Johnson et al., NYC DOHMH, “Characteristics of the Built Environment and the Presence of the Norway Rat in New York City: Results From a Neighborhood Rat Surveillance Program, 2008–2010,” *Journal of Environmental Health* (6/2016).
9. For example, see research on impacts of waste handling interventions within apartments in Patrick Kinney et al., “On the Front Lines: An Environmental Asthma Intervention in New York City,” *American Journal of Public Health* 92, vol. 1 (6/2002), <http://ajph.aphapublications.org/doi/abs/10.2105/AJPH.92.1.24>.
10. Eliminating single-use disposables in New York City requires policy change at both the city and state level. Article §81.46 of the NYC Health Code allows for the use of customers’ reusable beverage containers in restaurants, quick-service food establishments and delis; New York state regulates all statewide food retail operations, from supermarkets to bodegas. According to section 271-8.3, the state’s food safety regulations on dispensing utensils, personal containers are not allowed.

Appendix

241	Best Practice Strategies for Building Design
245	Best Practice Strategies for Construction & Demolition Waste
247	Best Practice Strategies for Collection & Urban Design
248	Building Rules & Standards
249	Building Standards & Certifications
250	LEED v4 Waste Management Credits
256	Definitions
257	Acronyms
258	Photo Credits
259	Waste Calculator Assumptions & References
262	Acknowledgements

BEST PRACTICE STRATEGIES FOR BUILDING DESIGN

Planning For Waste As A Material Flow

	RESIDENTIAL	COMMERCIAL
2.01 DETERMINE WASTE STREAMS AND QUANTITIES	x	x
2.02 PLAN A ROUTE	x	x
Consider containers for transport and storage.	x	x
Consider chutes and sorters.	x	
2.03 DESIGN STORAGE SPACE	x	x
2.04 PLAN FOR COLLECTION	x	x
2.05 CONSIDER STAFF PROCEDURES	x	x
2.06 PLAN FOR TAKEBACK OF DELIVERY MATERIALS	x	x
2.07 CONSIDERATIONS FOR MULTI-TENANT BUILDINGS		x

BEST PRACTICE STRATEGIES FOR BUILDING DESIGN (CONT'D)

Waste Diversion Strategies

	RESIDENTIAL	COMMERCIAL
2.08 PROVIDE EQUAL CONVENIENCE DISPOSAL (RESIDENTIAL)	x	
Apartments: Design receptacles for all waste streams together within apartments.	x	
Multifamily residential: Design for co-location of organics and all waste streams in waste rooms.	x	
2.09 PROVIDE EQUAL CONVENIENCE DISPOSAL (COMMERCIAL)		x
Offices: Create central waste stations.		x
Restaurant recycling stations: Design recycling stations to accommodate all streams generated within the facility.		x
Restaurant kitchens: Provide for all food waste generated at all food preparation areas.		x
Waste storage locations and loading docks: Provide bins of appropriate size at each location where waste is handled.		x
2.10 PROVIDE CLEAR VISUAL CUES AND SIGNAGE	x	x
Use standard signage.	x	x
Design container openings to cue user of suitable contents.		x
Use color to indicate waste stream.	x	
2.11 PROVIDE OPPORTUNITIES FOR FEEDBACK		
Display waste data to change behavior.	x	x
Virtual feedback	x	x
2.12 DEVELOP AWARENESS & EDUCATION PROGRAMS	x	x
2.13 DESIGN FOR OCCUPANCY (RESIDENTIAL)	x	
2.14 DESIGN FOR OCCUPANCY (COMMERCIAL AND INSTITUTIONAL)		x

BEST PRACTICE STRATEGIES FOR BUILDING DESIGN (CONT'D)

Waste Reduction Strategies

	RESIDENTIAL	COMMERCIAL
2.15 PROVIDE SHARED ASSETS AND SERVICES	x	x
Provide shared services for functions like cleaning, maintenance and repair. Consider containers for transport and storage.	x	x
2.16 REDUCE MATERIALS CONSUMPTION		x
Design to reduce the use of packaging and disposable tableware.		x
Provide compostable dishware and utensils.		x
Design to reduce the use of paper.		x
2.17 REDUCE FOOD WASTE GENERATION	x	x
Design food storage to reduce waste.	x	x
Design food display to reduce waste.		x
Design for equipment to track food waste to change purchasing decisions.		x
2.18 FACILITATE DONATION AND REUSE	x	x
Design storage for bulk items.	x	x
Design for access to and refrigeration of food donations.	x	x
2.19 DESIGN TO INCORPORATE FINANCIAL INCENTIVES SUCH AS SAYT (RESIDENTIAL)	x	
Design so financial incentives can be applied at household level.	x	
2.20 DESIGN TO INCORPORATE TRANSPARENT PRICING BY STREAM (COMMERCIAL)		x
Design commercial buildings to track individual business waste and provide feedback.		x

BEST PRACTICE STRATEGIES FOR BUILDING DESIGN (CONT'D)

Volume Reduction Strategies

	RESIDENTIAL	COMMERCIAL
2.21 VOLUME REDUCTION EQUIPMENT: RESIDENTIAL COMPACTORS & BALERS	x	
2.22 VOLUME REDUCTION EQUIPMENT: COMMERCIAL COMPACTORS, BALERS, CRUSHERS & GRINDERS		x
2.23 ORGANIC WASTE PRETREATMENT (RESIDENTIAL)	x	
2.24 ORGANIC WASTE PRETREATMENT (COMMERCIAL)		x

BEST PRACTICE STRATEGIES FOR CONSTRUCTION & DEMOLITION WASTE

Material Optimization Strategies

Lean design that right-sizes the building, optimizes the materials used, and considers end of life

2.25 MAXIMIZE ASSET UTILIZATION THROUGH PROGRAMMING

Program to make the most use of an asset.

Design to increase the usage of spaces and equipment within a building.

2.26 DESIGN TO OPTIMIZE MATERIAL USAGE

2.27 DESIGN TO REDUCE WASTE GENERATED DURING CONSTRUCTION

Coordinate dimensions and minimize finish types

Design for off-site construction

Use Building Information Modeling (BIM)

2.28 DESIGN FOR DECONSTRUCTION AT THE END OF LIFE OF A BUILDING COMPONENT

Design for easy refurbishment of isolated materials.

Design for deconstruction and disassembly.

Provide material information: material passports.

Consider suppliers willing to take back materials

BEST PRACTICE STRATEGIES FOR CONSTRUCTION & DEMOLITION WASTE (CONT'D)

Material Selection Strategies

Closing the materials loop through reuse and recycling

2.29 REUSE EXISTING MATERIALS—AND BUILDINGS—ON-SITE

2.30 USE RECLAIMED COMPONENTS AND MATERIALS

2.31 SPECIFY RECYCLABLE MATERIALS WITH HIGH RECYCLED CONTENT

Waste Management Strategies

Reducing and diverting waste generated onsite during construction

2.32 REQUIRE A CONSTRUCTION WASTE MANAGEMENT PLAN

2.33 REDUCE SURPLUS MATERIAL

2.34 SEPARATE CONSTRUCTION WASTE ON-SITE

BEST PRACTICE STRATEGIES FOR COLLECTION & URBAN DESIGN

Neighborhood-Scale Collection

Provide large containers/compactors shared between buildings

3.01 PROVIDE LOADING AREA AT BASE OF A BUILDING THAT CAN ALSO BE USED BY OTHER BUILDINGS

3.02 PROVIDE CENTRAL COLLECTION FACILITY WITH MULTIPLE COMPACTOR CONTAINERS SHARED BETWEEN BUILDINGS

3.03 PROVIDE A SYSTEM OF PNEUMATIC TUBES CONNECTING BUILDINGS TO A CENTRAL TERMINAL

3.04 PROVIDE A SYSTEM OF PNEUMATIC TUBES CONNECTING SHARED INPUTS TO A CENTRAL FACILITY

Access to Efficient Collection & Recycling as a Public Amenity

Shift from door-to-door collection to shared collection points

3.05 SHARED SURFACE CONTAINERS IN THE PUBLIC REALM OR ON PUBLIC AGENCY PROPERTY

3.06 SHARED SUBMERGED CONTAINERS IN THE PUBLIC REALM OR ON PUBLIC AGENCY PROPERTY

3.07 STAFFED DROP-OFF LOCATIONS

Integrated Planning

3.08 DESIGN STREETSCAPES THAT ALLOW CURBSIDE ACCESS TO CONTAINERS

3.09 INCORPORATE COMMUNITY INTO COLLECTION OPERATIONS

BUILDING RULES & STANDARDS

Applicable rules and standards for buildings in NYC

RULES	ACRONYM	RELEVANT SECTIONS	APPLIES TO	VERSION REFERRED TO / LAST UPDATED	LINK
Department of Sanitation New York Rules and Regulations (condensed from NYC Health and Administrative Code)	DSNYRR	All	All Buildings in NYC	rev. June 2015	Link
NYC Administrative Code	NYCAC	Title 16, Sanitation	All Buildings in NYC	—	—
Rules of the City of New York	RCNY	Title 16, Sanitation	All Buildings in NYC	—	—
New York City Building Code	BC	1213	New buildings and selectively to existing buildings (as defined in BC 28-102) in NYC	2014	Link
New York State Multiple Dwelling Law	MDL	81	All residential buildings with 3 or more dwelling units in cities with population >325,000 in NYS	1929	Link
New York City Housing Maintenance Code	HMC	27-2020	All residential dwellings	1988	Link
Zoning Resolution of the City of New York	ZR USZWBC	—	All new buildings and selectively to existing buildings (as defined in ZR 11-111) in NYC	5/21/2017	Link

STANDARDS	ACRONYM	RELEVANT SECTIONS	APPLIES TO	VERSION REFERRED TO / LAST UPDATED	LINK
LEED (Leadership in Energy and Environmental Design)	LEED v4 DSNYRR	See LEED table	Voluntary standard for all buildings; mandatory for certain NYC-funded buildings per LL86/2005 and updated by LL32/2016	Version 4	Link
Total Resource Use and Efficiency : Zero Waste Facility Certification	TRUE	All	Voluntary for facility certification	—	Link
Enterprise Green Communities Criteria NYC Overlay	EGCC	6 (Materials)	All new construction and substantial rehabilitation projects receiving funding from HPD	2015	Link

Note that references to code and rules throughout the guidelines are for informational purposes only and should not be a substitute for consulting the source.

BUILDING STANDARDS & CERTIFICATIONS

Total Resource Use and Efficiency Certification

In 2016, the United States Zero Waste Business Council, which had a certification program for zero waste facilities and professionals, joined forces with the US Green Building Council (USGBC). Previously called Zero Waste Facility Certification, TRUE—short for Total Resource Use and Efficiency—is certified under the Green Building Certification Institute (GBCI), the body that also certifies LEED. TRUE credits are aligned with LEED v4 credit requirements for Buildings Operations and Maintenance (LEED O+M). The organizations are working to streamline other LEED and TRUE credits.

TRUE defines “zero waste” as the international Zero Waste International Alliance does: “no waste to landfill, incineration and the environment.” See [“What Is Zero Waste?”](#).

Requirements for certification include the following:

- A zero waste policy is in place.
- At least 90% overall diversion from landfill and incineration for nonhazardous wastes.
- Diverted materials are reduced, reused, recycled, composted and/or recovered for productive use in nature or the economy.
- When leaving a company site, each material cannot exceed 10% contamination.

Credits are extensive and involve all aspects of the material cycle. The 15 credit categories— Redesign, Reduce, Reuse, Compost (ReEarth), Recycle, Zero Waste Reporting, Diversion from landfill, incineration and environment (90%–100%), Zero Waste Purchasing, Leadership, Training, Zero Waste Analysis, Upstream Management, Hazardous Waste Prevention, Closed Loop and Innovation—and a total of 81 points. The four certification levels are, from lowest to highest, Certified, Silver, Gold and Platinum.

Living Building Challenge

A program of the International Living Future Institute (ILFI), the [Living Building Challenge](#) calls itself a “philosophy, certification and advocacy tool for projects to move beyond merely being less bad and to become truly regenerative.” Along with requiring net-positive energy and water, it has a petal for net-positive waste. A project team is required to create a Materials Conservation Management plan that explains how the project optimizes materials in design, construction, operation and end-of-life phases. It requires 80%–100% diversion of on-site C&D materials, and dedicated infrastructure for the collection of “recyclable and compostable food scraps.” It also requires attention to be paid to the durability of the products composing the building and an end-of-life plan for adaptable reuse and deconstruction. See [ILFI](#).

LEED V4 WASTE MANAGEMENT CREDITS

The [USGBC website](#) states that one benefit of LEED v4 is “an expanded focus on materials—in addition to considering the usage of materials in buildings, it integrates a comprehensive approach to evaluate the impact of materials on human health and the environment.” The Materials and Resource credits address all the strategies in the United States Environmental Protection Agency’s solid waste management hierarchy: reduction, reuse, recycling and waste to energy. Leed has five project types, and each one has different credits for waste management, as shown in the table below.

LEED V4 FOR BUILDING DESIGN AND CONSTRUCTION (BD+C)

SUSTAINABLE SITES		
Credit	As part of site assessment, survey existing site and inventory on-site buildings, infrastructure and materials that can be reused or recycled.	1
MATERIALS AND RESOURCES		
Prerequisite	STORAGE AND COLLECTION OF RECYCLABLES	Required
	Provide dedicated areas accessible to waste haulers and building occupants for the collection and storage of recyclable materials for the entire building.	
	Collection and storage areas can be in separate locations.	
	Recyclable materials must include mixed paper, corrugated cardboard, glass, plastics and metals.	
	Take appropriate measures for the safe collection, storage and disposal of two of the following: batteries, mercury-containing lamps and e-waste.	
Prerequisite	CONSTRUCTION AND DEMOLITION WASTE MANAGEMENT PLANNING	Required
	Identify waste diversion goals.	
	Select collection and diversion methods.	
	Draft a construction waste management plan.	
	Produce a waste report.	
Prerequisite	PBT SOURCE REDUCTION: MERCURY (HEALTHCARE ONLY)	Required
	Plan for collecting and recycling mercury-containing equipment.	
Credit	BUILDING LIFE-CYCLE IMPACT REDUCTION	5
	Reuse or salvage building materials from off- or on-site as a percentage of the surface area.	
Credit	BUILDING PRODUCT DISCLOSURE AND OPTIMIZATION: SOURCING OF RAW MATERIALS	2
	Reuse includes salvaged, refurbished or reused products.	
	Use products with recycled content.	
Credit	BUILDING PRODUCT DISCLOSURE AND OPTIMIZATION: MATERIAL INGREDIENTS	2
	End-use products are Cradle to Cradle certified.	
Credit	FURNITURE AND MEDICAL FURNISHINGS (HEALTHCARE ONLY)	2
	Use salvaged, refurbished or reused products.	
	Use products with recycled content.	
Credit	CONSTRUCTION AND DEMOLITION WASTE MANAGEMENT	2
	Divert at least 50% of the total construction and demolition material, or for one point, at least 75% of the total construction and demolition material.	
	Generate no more than 2.5 pounds of construction waste per square foot of the building's floor area.	
Total Possible Points		14

LEED V4 FOR BUILDING OPERATIONS AND MAINTENANCE (O+M)

SUSTAINABLE SITES		
Prerequisite	SITE MANAGEMENT POLICY	Required
	Organic waste management (returned to the site or diverted from landfills)	
Credit	SITE MANAGEMENT	1
	Divert from landfills 100% of plant material waste via low-impact means.	
MATERIALS AND RESOURCES		
Prerequisite	ONGOING PURCHASING AND WASTE POLICY	Required
	Environmentally preferable purchasing	
	Solid waste management	
Prerequisite	FACILITY MAINTENANCE AND RENOVATIONS POLICY	Required
	Waste management policy for maintenance and renovations	
Credit	PURCHASING: ONGOING	1
	Postconsumer recycled content	
	Extended use	
Credit	PURCHASING: FACILITY MANAGEMENT AND RENOVATION	2
	Use products with recycled content.	
	Reuse includes salvaged, refurbished or reused products.	
	End-use products are Cradle to Cradle certified.	
Credit	SOLID WASTE MANAGEMENT: ONGOING	2
	Maintain a waste reduction and recycling program that reuses, recycles or composts at least 50% of the ongoing waste and at least 75% of the durable goods waste.	
	Safely dispose of all discarded batteries and all mercury-containing lamps.	
Credit	SOLID WASTE MANAGEMENT: FACILITY MANAGEMENT AND RENOVATION	2
	Divert at least 70% of the waste generated by facility maintenance and renovation activities from disposal in landfills and incinerators.	
Total Possible Points		8

LEED V4 FOR INTERIOR DESIGN AND CONSTRUCTION (ID+C)

MATERIALS AND RESOURCES		
Prerequisite	STORAGE AND COLLECTION OF RECYCLABLES	Required
	Provide dedicated areas accessible to waste haulers and building occupants for the collection and storage of recyclable materials for the entire building.	
	Collection and storage areas can be separate locations.	
	Recyclable materials must include mixed paper, corrugated cardboard, glass, plastics and metals.	
	Take appropriate measures for the safe collection, storage and disposal of two of the following: batteries, mercury-containing lamps and e-waste.	
Prerequisite	CONSTRUCTION AND DEMOLITION WASTE MANAGEMENT PLANNING	Required
	Identify waste diversion goals.	
	Select collection and diversion methods.	
	Draft a construction waste management plan.	
	Produce a waste report.	
Credit	INTERIORS LIFE-CYCLE IMPACT REDUCTION	4
	Reuse or salvage interior nonstructural elements for at least 50% of the surface area.	
	Reuse, salvage or refurbish furniture and furnishings for at least 30% of the total furniture and furnishings cost.	
	Conduct an integrative planning process to increase the useful life of the project space.	
Credit	BUILDING PRODUCT DISCLOSURE AND OPTIMIZATION: SOURCING OF RAW MATERIALS	2
	Materials reuse	
	Recycled content	
Credit	BUILDING PRODUCT DISCLOSURE AND OPTIMIZATION: MATERIAL INGREDIENTS	2
	End-use products are Cradle to Cradle certified.	
Credit	CONSTRUCTION AND DEMOLITION WASTE MANAGEMENT	2
	Divert at least 50% of the total construction and demolition material or, for one point, at least 75% of the total construction and demolition material.	
	Generate no more than 2.5 pounds of construction waste per square foot of the building's floor area.	
Total Possible Points		10

LEED V4 FOR NEIGHBORHOOD DEVELOPMENT (ND)

GREEN INFRASTRUCTURE AND BUILDINGS		
Credit	BUILDING REUSE	1
	Five buildings or fewer: Reuse 50% of one such building, based on surface area.	
	More than five buildings: Reuse 20% of the total surface area of such buildings.	
	Do not demolish any historic buildings or contributing buildings in a historic district, or portions thereof, or alter any cultural landscapes as part of the project.	
Credit	RECYCLED AND REUSED INFRASTRUCTURE	1
	Use materials for new infrastructure such that the sum of the postconsumer recycled content, on-site reused materials and one-half of the preconsumer recycled content constitutes at least 50% of the total mass of infrastructure materials.	
Credit	SOLID WASTE MANAGEMENT	1
	Include one recycling or reuse station dedicated to the separation, collection and storage of materials for recycling, or locate the project in a local government jurisdiction that provides recycling services.	
	or Include at least one drop-off point for potentially hazardous office or household wastes and establish a plan for postcollection disposal or use, or locate the project in a local government jurisdiction that provides collection services.	
	or Include at least one compost station or location and establish a plan for postcollection use, or locate the project in a local government jurisdiction that provides composting services.	
	or On every mixed-use or nonresidential block, or at least every 800 feet, include recycling containers either adjacent to or integrated into the design of other receptacles.	
	or Recycle, reuse or salvage at least 50% of nonhazardous construction, demolition and renovation debris.	
Total Possible Points		3

LEED V4 FOR HOMES DESIGN AND CONSTRUCTION

MATERIALS AND RESOURCES		
Credit	CONSTRUCTION AND DEMOLITION WASTE MANAGEMENT	3
	Reduce total construction waste or divert from landfills and incinerators a large proportion of the waste generated from new construction.	
Total Possible Points		3

DEFINITIONS

Bulk Waste	Objects too large to fit in a garbage bag or wheeled bin, such as furniture and metal appliances, aka white goods. (Designated as a separate stream by DSNY)
Capture Rate	The percentage of materials designated for recycling that is actually set out for separate collection.
Compostables	Biodegradable material that decomposes over a specific set of conditions and time defined by ASTM D6400 and D6868. (Usually requires an industrial composting facility) Biodegradable Products Institute has a certification for compostable products.
Construction and Demolition Waste C&D	Discarded building materials, packaging, and rubble generated during the construction, renovation and demolition of buildings and structures. Does not include land-clearing and excavation materials that are natural (e.g., rock, soil, stone, vegetation)
Contamination Rate	The percentage of materials set out for separate recycling collection that is not accepted in NYC's recycling program.
Disposal	Final disposition of waste materials through landfilling or an energy-recovery process involving techniques such as combustion, gasification, or pyrolysis.
Diversion, Diversion Rate	From a general waste-management perspective, "diversion" is any combination of reuse, recycling, and composting activities that reduces the volume of waste disposed. "Diversion rate" is the percentage of all material set out for collection that is recycled.
Garbage	Same as 'waste.' A colloquial term.
MGP	Metal, glass, and plastic: materials designated by DSNY for mandatory source-separation for recycling. As currently defined by DSNY, the only plastics included in this designation are rigid.
Municipal Solid Waste	The subcategory of solid waste that includes any material discarded by households, businesses, or institutions. Among the waste categories it does not include are industrial wastes, construction and demolition debris, and sanitary wastes.
OCC	Old corrugated cardboard—post-consumer cardboard. Designated by DSNY as part of the "Paper" stream, but generally collected separately by private carters.

Organics	As designated by DSNY: food scraps, yard waste and food-soiled paper.
Paper, Mixed Paper	Any clean paper suitable for use as a feedstock in making new paper or cardboard products, i.e., any paper without significant contamination from liquids or soiling from food or other organics.
Recycling	The process of diverting discarded material from disposal, generally through source-separated set-out and collection, intermediate processing at a materials-recovery facility (MRF), and end-use manufacturing that alters the form of the secondary material to make a new product. Composting is a form of recycling.
Refuse	Items or materials that are discarded and disposed.
Reuse	Using an object or material again, either for its original purpose or for a similar purpose, without significantly altering the physical form of the object or material.
Single-Stream Recycling	Source-separated recycling in which all recyclables other than those designated as "organics" may be set out in the same bag or container for collection in a single truck or truck compartment.
Solid Waste	Garbage, refuse, sludges, and other discarded solid materials resulting from residential activities, and industrial and commercial operations.
Source Reduction/ Waste Mimimization/ Waste Prevention/ Waste Reduction	Actions or choices taken before waste is generated to reduce the number or volume of discards.
Trash	Portion of waste stream which is not recyclable
Waste	Discarded material, including any sub-streams that may be separated at the source for diversion from disposal by some form of recycling or organics processing.
Waste Generation Rate	The rate at which waste is set out for collection, typically reported in terms of amounts per generator per time period (e.g. pounds per capita per week).

References:

1. Waste Prevention World, Glossary of Waste Prevention Terms, <http://www.calrecycle.ca.gov/reducewaste/define.htm#WaPrevTerms>
2. DSNY WCS multi apartment study 2005

ACRONYMS

100RC	100 Resilient Cities
AD	Anaerobic digestion
ANSI	American National Standards Institute
BC	NYC Building Code
BIC	NYC Business Integrity Commission (regulates commercial waste haulers, among other business entities)
BPP	Builders pavement plan
AIA, AIANY	American Institute of Architects; AIA NY
BD+C	Building design and construction (LEED project type)
BIM	Building information modeling
BOD	Biological oxygen demand
BPE	Building Product Ecosystems
C40	A network of the world's megacities committed to addressing climate change
C+D	Construction and demolition waste
CDL	Clean dimensional lumber
COTE	Committee on the Environment, AIA, NY
DCP	NYC Department of City Planning
DEP	NYC Department of Environmental Protection
DDC	NYC Department of Design and Construction
DOE	NYC Department of Education
DOHMH	NYC Department of Health and Mental Hygiene
DOT	NYC Department of Transportation
DSNY	NYC Department of Sanitation
EDC	NYC Economic Development Commission
EGCC	Enterprise Green Communities Criteria NYC Overlay (national green building criteria for affordable multifamily housing, used by HPD)
E-Waste	Electronic waste
EZ-Pak	Front-end or rear-end loading containers
FEL	Front-end-loaded container
GBCI	Green Building Certification Inc. (certification provider for LEED rating system of the US Green Building Council)
GT	Gross tonnage
GWB	Gypsum wallboard
HDPE	High-density polyethylene
HPD	NYC Housing Preservation and Development Agency
ID+C	Interior design and construction (LEED project type)

IDSANY	Industrial Design Society of America, NYC Chapter
ILFI	International Living Future Institute
LDPE	Low-density polyethylene
LEED	Leadership in Energy and Environmental Design (rating system developed by the US Green Building Council)
MEP	Mechanical, electrical and plumbing
MGP	Metal, glass, paper (the components of a dual-stream waste fraction designated for recycling)
MOS	NYC Mayor's Office of Sustainability
M-SWAB	Manhattan Solid Waste Advisory Board
ND	Neighborhood development (LEED project type)
NRDC	Natural Resources Defense Council
NYCHA	NYC Housing Authority
NYC ZR	NYC Zoning Resolution
O+M	Building operations and maintenance (LEED project type)
OneNYC	"One New York: The Plan for a Strong and Just City," City of New York
OSHA	Occupational Safety and Health Administration, US Department of Labor
PBT	Persistent, bioaccumulative and toxic substances
PP	Polypropylene
PVC	Polyvinyl chloride
RCI	Recycling Certification Institute
RCNY	Rules of the City of New York
REBNY	Real Estate Board of New York
REL	Rear-end-loaded container
RoRo	Roll-on/roll-off container or the truck that transports such a container
SAYT	Save As You Throw (a unit pricing program for waste collection to incentive waste reduction)
SOPs	Standard operating procedures
TRUE	Total Resource Use and Efficiency (zero waste certification program)
TSS	Total suspended solids
UGC	Urban Green Council
USGBC	US Green Building Council
VMT	Vehicle miles traveled
WWTP	Wastewater Treatment Plant
ZR	Zoning Resolution
ZWDG	Zero Waste Design Guidelines
ZWIA	Zero Waste International Alliance

WASTE CALCULATOR ASSUMPTIONS

VOL/ WEIGHT RATIOS	CU YD/ TON
Refuse Multifamily	21.05
Refuse Commercial	14.49
MGP - commingled recyclables	18.02
Paper	6.19
Cardboard- OCC flattened	18.87
Paper and Cardboard combined	26.67
Organics - Commercial	2.00
Organics - Residential	4.32
Textiles	13.33
E-waste	5.65

WASTE GENERATION DATA RESIDENTIAL	TONS/CAPITA/ YEAR
Total all Streams	0.44
Trash	0.11
Paper	0.04
Cardboard	0.04
MGP	0.07
Organics	0.14
Textiles	0.03
E-Waste	0.01

COMPACTION RATIOS	COMMERCIAL	RESIDENTIAL
Vertical compactor	33%	33%
35 cu yd compactor (all streams except organic)	33%	33%
35 cu yd compactor organic*	80%	80%
Baler MPG	25%	50%
Baler cardboard	12.5%	25%
Organics to drain**	10%	10%
Organic pretreatment	25%	25%

WASTE GENERATION DATA COMMERCIAL (TONS/EMPLOYEE/YEAR)	TRASH	MGP/ UNIT	PAPER / UNIT	CARDBOARD / UNIT	ORGANIC WASTE / UNIT	TOTAL
Restaurant or Food Service	0.003	0.538	0.643	0.182	1.382	2.75
Hotels	0.007	0.499	0.397	0.155	0.583	1.64
Offices	0.002	0.401	0.590	0.246	0.157	1.40
Retail Grocery	0.003	0.389	0.389	3.455	2.048	6.28
Retail (non-food)	0.006	0.474	0.494	0.296	0.388	1.66

WASTE CALCULATOR ASSUMPTIONS (CONT'D)

THRESHOLDS FOR SUGGESTED VOLUME REDUCTION EQUIPMENT			
WASTE STREAM	EQUIPMENT	THRESHOLD CU YD/ YR (UNCOMPACTED)	REASONING
Refuse	vertical compactor***	416	Over 8 cu yd / week uncompacted
	35 cu yd compactor	4412	When the compactor would need emptying (80% volume) once a week
MGP	35 cu yd compactor	2206	When the compactor would need emptying (80% volume) once every 2 weeks
	Baler	104	Over 2 cu yd / week (manufacturer's recommendation)
Cardboard	35 cu yd compactor	2206	When the compactor would need emptying (80% volume) once every 2 weeks
	Baler	104	Over 2 cu yd / week (manufacturer's recommendation)
Organics	Organic Pretreatment	91	Based on 250 lbs /day generation (food waste consultant recommendation)
	35 cu yd compactor	1820	When the compactor would need emptying (80% volume) once a week

BALE SIZE	INCHES	NOTES
Cardboard Commercial	30×20×24	Assume can stack 3 high, to 6'
Cardboard Residential	30×20×10	Assume can stack 7 high, to 5'-10"
Metal and plastic	30×20×24	Assume can stack 3 high, to 6'

NOTES:

- Bulk Waste is excluded from the calculator and storage for this should be provided for commercial and residential occupancies.
- Commercial calculator does not account for streams which may or may not be generated depending on occupancy such as e-waste, textiles, grease, oil, industrial waste. Storage should be provided for these additional streams as relevant.
- Strongly recommended equipment is always at double the suggested equipment threshold
- Container recommendations and volume equipment for residential occupancies are based on DSNY rules
- Container and bin sizes are based on the infographics ('Waste Bins in Buildings' and '20-40 cu yd containers and 1-8 cu yd containers' and in the Zero Waste Design Guidelines
- Area taken up by bags stacked up is assumed to be similar to the volume/SF as tilt trucks or 64 gallon wheeled bins, at 0.05 cu yd / sq ft
- When a baler is used for MGP, we have not accounted for the separate storage for glass required
- *If compostable dishware is used then the volume of organic waste will be much larger than calculated. With large volumes a 35 cu yd compactor should be considered.
- ** This is the residual organic waste that can't go in the equipment
- *** For residential occupancies a vertical compactor is recommended over 12 units per code

WASTE CALCULATOR REFERENCES

- Bramidan, "Balers," <http://www.bramidan.us/Products/Vertical-balers/B-series/Product/B4.aspx#technicaldata>
- CalRecycle, "2014 Generator-Based Characterization of Commercial Sector Disposal and Diversion in California," September 10, 2015, <http://www.calrecycle.ca.gov/publications/Documents/1543/20151543.pdf>
- City of New York, Department of Sanitation, "2013 NYC Curbside Waste Characterization Study," <https://www1.nyc.gov/assets/dsny/docs/2013-Waste-Characterization-Study.pdf>
- City of New York, Mayor's Office of Environmental Coordination, CEQR: *City Environmental Quality Review, Technical Manual* (NY, City of New York: 2014), http://www.nyc.gov/html/oec/downloads/pdf/2014_ceqr_tm/2014_ceqr_technical_manual.pdf
- City of New York, Department of Sanitation, "New York City Commercial Solid Waste Study and Analysis, 2012 Summary Report," August, 2015, https://www1.nyc.gov/assets/dsny/docs/about_2012-commercial-waste-study_0815.pdf
- City of New York, Department of Sanitation, "2015 NYC Organics Collection Report," 22, <https://www1.nyc.gov/assets/dsny/downloads/pdf/studies-and-reports/OrganicsCollection-LL77-NYCOrganicsCollectionReport-2015.pdf>
- City of New York, Department of Sanitation, "Annual Report: New York City Municipal Refuse and Recycling Statistics: Fiscal Year 2016," https://www1.nyc.gov/assets/dsny/docs/about_dsny-non-dsny-collections-FY2016.pdf
- Marathon Equipment, "Compaction Products," <http://www.marathonequipment.com/products/self-contained-compactors/rj-100sc>
- Toter, "Waste & Recycling Carts" (Statesville, NC: 2016)
- US Census Bureau, "Quick Facts: New York," <https://www.census.gov/quickfacts/fact/table/NY/PST120216>
- US EPA, Office of Resource Conservation and Recovery, "Volume-to-Weight Conversion Factors," April, 2016, https://www.epa.gov/sites/production/files/2016-04/documents/volume_to_weight_conversion_factors_memorandum_04192016_508fnl.pdf

PHOTO CREDITS

3 DSNY; 5 left Urban Green Council website; 6 AIANY; 12 DSNY; 19 Seth GaleWyrick; 20 top Malcolm Pinckney/ NYC Parks; 20 bottom left NYC DEP; 20 bottom right NYC DOT; 21 left DSNY; 21 right Vibek Raj Maurya; 22 DSNY; 24 David Salomon; 28 DSNY; 29 public domain; 30 left “The ‘shopping basket’ through the ages” (CC BY-ND 2.0) by brizzle born and bred; 30 right “United Nations Headquarters” (CC BY-NC-ND 2.0) by United Nations Photo; 31 “Mushroom” (CC BY-NC-ND 2.0) by Lilmsmrtas; 33 Ellen MacArthur Foundation; 35 left Kim Mingo; 35 right DSNY; 36 left Umberto Salvagnin from Italy, Green Lichen, CC-BY-2.0; 36 right Murray Cox, courtesy of BKRot; 41 DSNY; 43-44 DSNY; 45 bottom DSNY; 52 top right Eddie Cheaz; 55 top left, bottom DSNY; 57 left, center left DSNY; 59 left Seren Morey; 59 right DSNY; 63 DSNY; 65 DSNY; 66 left DSNY; 67 DSNY; 73 Jonah Miller; 77 bottom right DSNY; 79 bottom left Vornado Realty Trust;

©John Benford / johnbenfordphoto.com; 81 top NRDC; 82 DSNY; 83 ©John Benford / johnbenfordphoto.com; 84 David Salomon; 85 top left DSNY; 95 left Vornado Realty Trust; 97 KraftMaid Cabinetry; 103 DSNY; 104 Tom Moggach, courtesy of Toast Ale; 105 illustration Miguel Diaz; 106 courtesy of GO Box / goboxpdx.com; 108 LeanPath; 109 Tom Estabrook / lookinbrooklyn.com; 111 Vornado Realty Trust; 112 left David Salomon; 112 right DSNY; 113 courtesy of Bramidan Baler; 118 Jamie Nash; 119 SEaB Energy; 122 ©Ben Blossom; 123 Naomi Cooper; 125 Steelcase Inc.; 126 Amanda Kaminsky, Building Product Ecosystems; 127 top ©David Mark Erickson; 128 Cooper Tank and Welding Corp.; 130 Iwan Baan, courtesy of The Living; 132 ©Garrett Rowland, courtesy of Gensler; 133 ©Arup; 134 top Philips Lighting; 134 bottom Ps2avery, Brooklyn Army Terminal Atrium, cropped, CC BY-SA 4.0; 135 left David Sundberg/ Esto, courtesy of FXFOWLE; 135 right

Amanda Kaminsky, Building Product Ecosystems; 137 ©Garrett Rowland, courtesy of Gensler; 140-142 DSNY; 143 The Solaire; 145-148 DSNY; 151 courtesy of Toronto 3Rs Ambassador Volunteer Program; 152 Global Green; 155-156 Vornado Realty Trust; 157 top and left ©Garrett Rowland, courtesy of Gensler; 158 Gensler, courtesy of Etsy; 160 Etsy; 161-162 Vornado Realty Trust; 163 Foodprint Group; 164 Eatly; 165 Eatly Graphics Team; 166 RXR Realty; 167 top RXR Realty; 168 image ©SOM I Neoscape; 170 Jamie Nash; 172 ©John Benford / johnbenfordphoto.com; 179 NYC DOT; 186 DSNY; 187 top and bottom right DSNY; 187 bottom left Shannon Bergstrom, Recycle Track Systems; 188 Action Environmental Group; 190 DSNY; 191 NYC DOT; 193 top DSNY; 194 top MariMatic Oy; 197 Underground Refuse Systems; 201 Municipality of The Hague (annotated by ZWDG team); 202 Bill Egbert; 203 top and bottom left Battery Park City Authority; 204 Gibbs

and Hill Inc.; 205 left Brian Ross; 205 right ©Kate Milford; 206-207 Sylvain Lefeuvre; 208 Caliper Architecture; 210 Eco-Emballages; 212 top Emmy de Graaf, courtesy of Municipality of The Hague; 212 bottom Municipality of The Hague; 214 top Ignasi Oliver; 214 bottom Picharchitects; 215 Ignasi Oliver; 216 Nadau Lavergne Architects; 217 Nadau Lavergne Architects (annotated by ZWDG team); 218-219 DSNY; 224 AIANY; 226 bottom The Solaire; 227 right NYC DOT; 230 top AIANY; 230 bottom NYC DOT; 233 image by Sam Schwartz Engineering, DPC; 236 Murray Cox, courtesy of BKRot; 238 top Ignasi Oliver; 238 bottom Impact Bioenergy Inc.

Note: Any images not listed are by ZWDG team. Photos appearing only in the website are: Policy splash page: Constructing Excellence in Wales; Research splash page: Impact Bioenergy Inc., and Recommendations splash page: AIANY.

ACKNOWLEDGMENTS

Guideline Development Team:

Kiss + Cathcart, Architects

Clare Miflin
Greg Kiss
Claire Mardian
Miguel Diaz
Emily Dickinson
Pebel Rodriguez

ClosedLoops

Benjamin Miller
Juliette Spertus

Foodprint Group

Christina Grace

AIANY

Eve Dilworth Rosen
Benjamin Prosky
Berit Hoff
Camila Schaulsohn
Meghan Edwards
Anne Shisler-Hughes

Exhibition Curator

Andrew Blum

Guidelines & Website Design

Project Projects:

Chris Wu
Liz Seibert Turow
Leigh Mignogna

Website Development

Systemantics

Thanks to all those who were active contributors to the development of the guidelines, including panelists and those who reviewed our drafts:

NYC Department of Sanitation

Anthony Ardolino
Bridget Anderson
Elizabeth Balkan
Joseph Marano
Chandra Hira
Kate Kitchener

NYC Department of City Planning

David Vega-Barachowitz
Claudia Herasme
David Vega-Barachowitz

NYC Department of Transportation

Michelle Craven
Kate Mikuliak

NYC Housing Authority

Jennifer Hiser

The Rockefeller Foundation

Devon Klatell
Monica Munn
Yvette Cabrera

Adina Daar, Wildability

Alison Novak, The Hudson Companies
Alyssa Zucker, Vornado Realty Trust
Amanda Kaminsky, Building Product Ecosystems

Amy Marpman, Recycle Track Systems

Bob Guarnaccia, Royal Waste
Cole Rosengren, Waste Dive

Dominic Hogg, Eunomia Consulting

Geoff Hurst, Related Companies
Helen Bielak, Columbia University
Hilary Young, Etsy

Ilana Judah, FXFOWLE Architects

Jacquelyn Ottman, We Hate to Waste
Julia D. Day, Gehl

Kendall Christiansen, New Yorkers for Responsible Waste Management

Louise Gouard, We Hate to Waste

Marisa Adler, RRS

Mark Chambers, Mayor's Office of Sustainability
 Martin Robertson, Strivers Gardens / New Bedford Mgt.
 Mike Reali, Royal Waste
 Naomi Cooper, Cooper Tank & Welding Corp.
 Ross Guberman, Great Forest
 Sarah Currie-Halpern, Think Zero, LLC
 Sarah Edwards, Eunomia Consulting
 Stefan Knust, Ennead Architects
 Susan Kaplan, BuildingWrX
 Tessa Vlaanderen, Circular Futures
 Troy Simpson, User Design Information Group / The Graduate Center, CUNY

Thanks to all those who brought their experience and perspective and collaborated in our workshops:

NYC Department of Sanitation
 James Marinello
 Pedro Suarez
 Sem Sepulveda

NYC Department of City Planning
 Monika Jain
 Ian Sinclair

NYC Department of Design and Construction
 Michael Balagur
 Rich Jones

NYC Department of Education
 Kathleen Corradi
 Meredith McDermott

Mayor's Office of Sustainability
 Kate Gouin
 Tom Eisele

NYC Department of Transportation
 Neil Gagliardi

NYC Economic Development Corporation
 Kate Daly

NYC Housing Authority
 Vlada Kennif

NYC Department of Environmental Protection
 Maria Cuenca

Abby Suckle, Abby Suckle Architects
 Amanda Stevens, We Hate to Waste
 Amer Jandali, Center for Social Innovation
 Ashley Muse, YR+G
 Ashley Wolitzer, We Hate to Waste
 Bethany Bowyer, Downtown Brooklyn Partnership
 Bob Muldoon, 32BJ Training Fund
 Brett Mons, 100 Resilient Cities, formerly DSNY
 Camilla Sigaard Anderson, Gehl
 Carl Hum, REBNY
 Caroline Bauer, Curb Your Litter, Greenpoint
 Catherine Bobenhausen, Vidaris
 Cecil Scheib, Urban Green Council

Chris Edmonds, YR+G
 Chris Garvin, Terrapin Bright Green
 Christen Johansen, Ennead Architects
 Christopher Halfnight, Urban Green Council
 Christopher Tepper, The Hudson Companies
 David Hurd, GrowNYC
 Derek Noah, We Hate to Waste
 Dimitri Smirnoff, Arizona State University
 Emily Kildow, Taconic Management
 Geoffrey Brock, Lend Lease
 Gregory Wessner, Open House New York
 Iris Chi, Global Green
 Jane Wolterding, Downtown Alliance
 Jeff Miles, MHG Architects
 Jeffrey Raven, Raven
 Jennifer Preston, BKSK architects
 Joanna Zhong, Global Green
 John Reilly, Interface
 Jonna Turesson, Arup
 Julie Moskovitz, Fete Nature Architecture
 Justin Green, Big Reuse
 Kaja Kühl, You Are the City
 Karen Oh, Vornado Management Companies
 Lacey Tauber, NYC council

Laura Rosenshine, Common Ground
Compost
Lauren Yarmuth, IDEO
Lydia Cap, We Hate to Waste
Lynn Fritzen, Lynn Fritzen Architecture
Mag Sim, Great Forest
Manolo Ampudia, Design for Social
Innovation
Matt Brueur, Sidewalk Labs
Matt de la Houssaye, Global Green
Meghan Haley-Quigley, Cosentini
Associates
Meredith Danberg-Ficarelli, Common
Ground Compost
Michael Deane, Turner Construction
Company
Nadia Ehlrohsy, Parsons
Peter Schon, IDSANY
Rei Moya, Stuyvesant Town
Rose Manco, The Durst Organization
Ryan Archer, Lisa Management
Ryan Grew, Downtown Brooklyn
Partnership
Sandy Diehl, SDGlobal Advisors
Sarah Bloomquist, Brooklyn SWAB
Scott Wolff, Keter Environmental
Services

Shannon Bergstrom, Recycle Track
Systems
Shi Chao Zheng, Keter Environmental
Services
Smita Rawoot, 100 Resilient Cities
Sunny Velez, REBNY
Sydney Mainster, The Durst Organization
Tiffany Broyles Yost, Arup
Venesa Alicea, Dattner Architects
Whitney Smith, Cosentini Associates
Yasmeen Shamsuddin, FXFOWLE
Architects

Other helpful input:

Albert Mateu, Green Bending
Biomimicry Professional Cohort 2016
Bruno Pomponio, Battery Park City
Authority
Caroline Bragdon, NYC Department of
Health and Mental Hygiene
Chief Michael Arney, NYC Department of
Sanitation
David Salomon, Frath Machinery Corp,
Nanoia Recycling Equipment
Dayna Baumeister, Biomimicry 3.8
Eddie Cheaz, 5 Eldridge St
Eliane Zimmer, lesarchitectures.com
Elizabeth Meltz, Eataly
Jim Frey, RRS
Kim Mingo, experience design
consultant
Laurie Kerr, Urban Green Council
Liz O’Nan, Related Companies
Makalé F. Cullen
Mariana Mogilevich, The Architectural
League of New York
Mark Bettin, theMART
Mark Kavulich, Wilkinson HiRise
Michael Gubbins, Albanese Organization
Mitchell Grant, RxRRRealty

Owen Rodgers, Building Manager (32BJ)
Pat Sapinsley, Urban Future Lab @ NYU
Rachid Ranchal
Soledad Tejada
Sukayana Paciorek, Brooklyn Navy Yard
Development Corporation
Toby Herzlich, Biomimicry 3.8
Wendy Feuer, NYC Department of
Transportation

Thanks to staff at the following buildings we visited:

Residential Building Visits

3320 Reservoir Oval East
Bronx

15 Eldridge Street
Manhattan

St. Johns Owner's Corporation
500 West 111st Street
Manhattan

Strivers Gardens Condominium
300 West 135th Street
Manhattan

22 Caton
22 Caton Place
Brooklyn

The Solaire
20 River Terrace
Manhattan

Grand Millennium Condominium
1965 Broadway
Manhattan

Stuyvesant Town- Peter Cooper Village
252 First Avenue
Manhattan

25 Lefferts Avenue
Brooklyn

The Studio Building
44 West 77th Street
Manhattan

Morningside Heights Housing
Corporation 80 LaSalle Street
Manhattan

The Crossroads
10 Rutgers Street
Manhattan

The Parkline
626 Flatbush Avenue
Brooklyn

250 Cabrini Blvd
Manhattan

Riverwalk Point
480 Main Street
Manhattan

Sky View Parc Luxury Condominiums
40-22 College Point Blvd
Queens

Avalon Fort Greene
343 Gold Street
Brooklyn

The Mayfair
301 East 69th Street
Manhattan

The Schwab House
11 Riverside Drive
Manhattan

Bell Park Manor Terrace
221-22 Manor Rd
Queens

Downtown by Phillippe Starck
15 Broad Street
Manhattan

315 East 69th Street Owners Corp.
315 East 69th Street
Manhattan

Alfred E. Smith Houses
21 St James Place
Manhattan

Commercial Building Visits

The Clocktower Building
325 Gold Street
Brooklyn

WeWork South Williamsburg
109 S Fifth
Brooklyn

Eataly NYC Flatiron
200 5th Avenue
Manhattan

Time Warner Center
10 Columbus Circle
Manhattan

Brooklyn Superhero Supply Co.
372 5th Avenue
Brooklyn

475 Fifth at Bryant Park
475 5th Avenue
Manhattan

Hearst Tower
300 West 57th Street
and 959 8th Avenue
Manhattan

WeWork 524 Broadway
524 Broadway
Manhattan

City Point
445 Albee Square West
Brooklyn

640 Fifth Avenue
640 5th Avenue
Manhattan

Huertas
107 1st Avenue
Manhattan

Etsy
117 Adams Street
Brooklyn

AMC Loews
19th St. East 6 890 Broadway
Manhattan

OTTO Enoteca e Pizzeria
1 5th Avenue
Manhattan

Gateway Center Mall
501 Gateway Drive
Brooklyn

Del Posto
85 10th Avenue
Manhattan

The Starrett-Lehigh Building
601 West 26th Street
Manhattan

Park Slope Food Coop
782 Union Street
Brooklyn

Dig Inn
856 8th Avenue
Manhattan

The Standard, High Line
848 Washington Street
Manhattan

Institutional Building Visits

The New School

72 5th Avenue

Manhattan

Columbia University

519 West 114th Street

Manhattan



